



www.eota.eu

EAD 060011-00-0802

November 2019

European Assessment Document for

Sootfire resistant chimney kits with
clay/ceramic flue liner,
working under wet conditions and
negative/positive pressure



The reference title and language for this EAD is English. The applicable rules of copyright refer to the document elaborated in and published by EOTA.

This European Assessment Document (EAD) has been developed taking into account up-to-date technical and scientific knowledge at the time of issue and is published in accordance with the relevant provisions of Regulation (EU) No 305/2011 as a basis for the preparation and issuing of European Technical Assessments (ETA).

Contents

1	1 Scope of the EAD	4
1.1	Description of the construction product	4
1.2	Information on the intended use(s) of the construction product	12
1.2.1	Intended use(s).....	12
1.2.2	Working life/Durability.....	12
1.3	Specific terms used in this EAD	13
1.3.1	Chimney fitting.....	13
1.3.2	Grout.....	13
2	Essential characteristics and relevant assessment methods and criteria	14
2.1	Essential characteristics of the product	14
2.2	Methods and criteria for assessing the performance of the product in relation to essential characteristics of the product	15
2.2.1	Resistance to fire from external to external.....	15
2.2.2	Resistance to fire from internal to external (sootfire resistance and thermal shock resistance).....	15
2.2.3	Gas tightness/leakage.....	16
2.2.4	Flow resistance.....	17
2.2.5	Thermal resistance.....	17
2.2.6	Durability/Condensate resistance.....	18
2.2.7	Durability of gas tightness/leakage against chemicals/corrosion Durability of compressive strength against chemicals	19
2.2.8	Thermal and fluid dynamic characteristics of chimneys serving more than one heating appliance	19
2.2.9	Air tightness of the outer wall	20
2.2.10	Minimum outer surface temperature at defined ambient temperature	22
2.2.11	Maximum height	22
2.2.12	Freeze thaw resistance	24
2.2.13	Durability in case of change of outer wall.....	24
3.1	System(s) of assessment and verification of constancy of performance to be applied	26
3.2	Tasks of the manufacturer	26
3.3	Tasks of the notified body	28
4	Reference documents	29
Annex A	Test sequence for the chimney kit W3 G.....	31

1 1 SCOPE OF THE EAD

1.1 Description of the construction product

The Sootfire resistant chimney kits with clay/ceramic flue liner, working under wet conditions and negative/positive pressure, named “chimney kit W3 G” thereafter, according to this EAD is a kit for multiwall sootfire resistant (Gxx) chimneys, working under dry (D) and wet (W) conditions, with corrosion resistance class 3 according to Table 2 of EN 1443¹, operating under negative pressure (N1), and positive pressure (P1) respectively, and a temperature class T400 to T600 according to EN 1443, Clause 4. The chimney kit W3 G may be manufactured as prefabricated storey height units, whereas storey height units means with defined length of the units. In case of storey height units their maximum length is stated in the ETA.

Examples for the chimney kit W3 G according to this EAD are given in Figures 1.1.1, 1.1.2 and Figures 1.1.4 and 1.1.5. The components are detailed thereafter.

Outer walls according to this EAD:

- outer wall made of clay/ceramic defined in EN 13069 and corresponding to the relevant temperature class envisaged for the chimney kit W3 G
- outer wall made of metal defined in EN 13063-1, Annex B
- outer wall made of concrete, optionally with additional coating (e.g., in case of storey height units and defined in the ETA), defined in EN 12446 and corresponding to the relevant temperature class envisaged for the chimney kit W3 G
- outer wall made of prefabricated units made of calcium silicate boards defined in EN 14306, whereas this EAD does not apply for calcium silicate boards without protection against weathering
- optionally including specific inner surface treatment made of foamed concrete (durable according to clause 2.2.4 of this EAD), used as thermal insulation; in case of side-by-side air flue chimney systems W3 G (see Figures 1.1.4 and 1.1.5), the outer wall may optionally be designed in a way that the foamed concrete is additionally used for thermal insulation of the separated air duct.
- In case of non-metallic outer walls (concrete, clay/ ceramic), the chimney kit W3 G may be extended by means of an outer wall made of metal according to EN 13063-1, Annex B, as shown in Figure 1.1.3 (change of outer wall), whereas the flue liner is continued for the whole kit.

For clay/ceramic flue liner and chimney fittings according to this EAD, EN 1457-2 (due to classification W in combination with G) applies, whereas

- in case of an outer wall made of concrete and including specific inner surface treatment made of foamed concrete, the flue liner type minimum A3N1 – for >T400 or flue liner type minimum B3N1 – for T400 respectively, apply. In this case “–” means tested without insulation according to Clause 9.2.2 in EN 1457-2 due to the specific outer wall. In addition, in case of an outer wall including specific inner surface treatment, water vapour diffusion class WA applies. In addition, depending on the composition of the product, thermal insulation may be applied to the flue liner.
- depending on the intended pressure class, the flue liner type minimum A3P1 and A3N1 respectively for >T400 and for T400 the flue liner type min. B3P1 and B3N1 respectively apply. In addition, water vapour diffusion classes WA/WB/WC apply.

For the component mortar for jointing outer wall for chimney kits W3 G according to this EAD, the compressive strength is defined in EN 13063-1. The mortar for jointing the flue liners is defined in EN 13063-2.

Sealings made of glass fibre fabrics are defined by technical data sheet. For components for thermal insulation according to this EAD, applied to the flue liner, EN 13063-1 applies.

¹ All undated references to standards or to EADs in this EAD are to be understood as references to the dated versions listed in chapter 4.

Chimney base are defined as follows:

- outer wall or outer wall elements
- flue liner made of clay/ceramic
- plate, made of concrete or suspension device made of metal
- the siphon made of metal or plastics
- concrete as filling material
- condensate collector
- cleaning and inspection door, optionally including sealing rope.

Other optional components for the chimney kit W3 G according to this EAD:

- thermal insulating outer wall element to be defined in the ETA, used in sections penetrating the ceiling or floor (see examples Figure 1.1.6 and 1.1.7);
- grout for outer walls with defined degree of shrinkage and expansion
- reinforcement and related ancillaries, consisting of metallic elements
- upper cleaning and inspection door
- closing devices in case of more than one heating appliance
- elements for ceiling penetration (see examples Figures 1.1.6 and 1.1.7)
- covering made of metal or concrete
- adapter for outer wall geometries in case of change of outer walls (from concrete, clay/ ceramic to metal), made of metal with steel grade at least 1.4301, according to Table 4 of EN 1856-1
- insulation kit for the top of the chimney kit W3 G consisting of:
 - o thermal insulation board defined in EN 13162
 - o jointing material and covering defined in EN 998-1
 - o rendering, with maximum force and elongation at maximum force according to relevant technical specification.

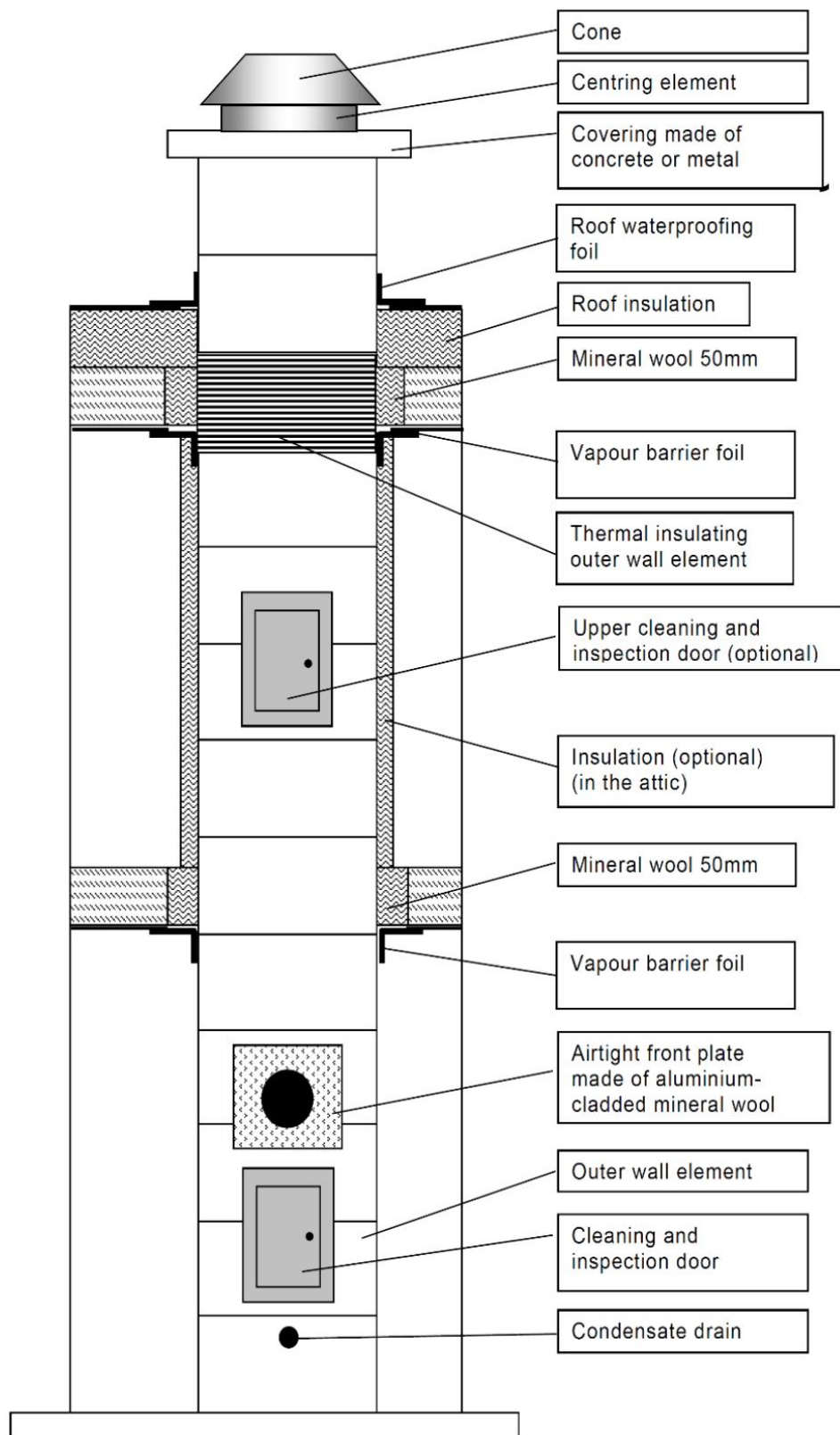

Figure 1.1.1: Assembled system with all components (Example)

Note: Figure 1.1.1 as example only; relevant for list of components is the descriptive list in Clause 1.1.

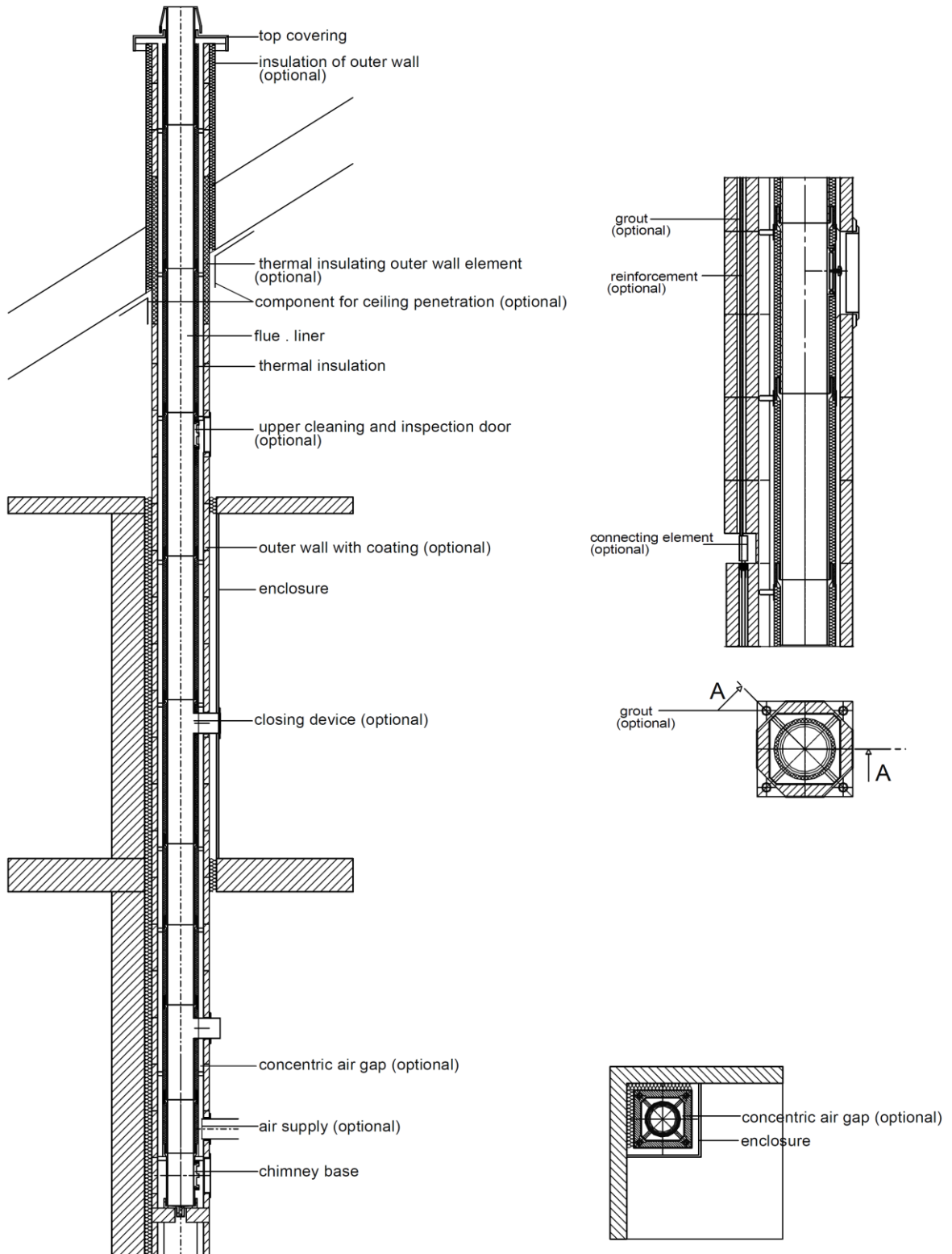

Figure 1.1.2: General drawing of chimney kit W3 G and its components (Example)

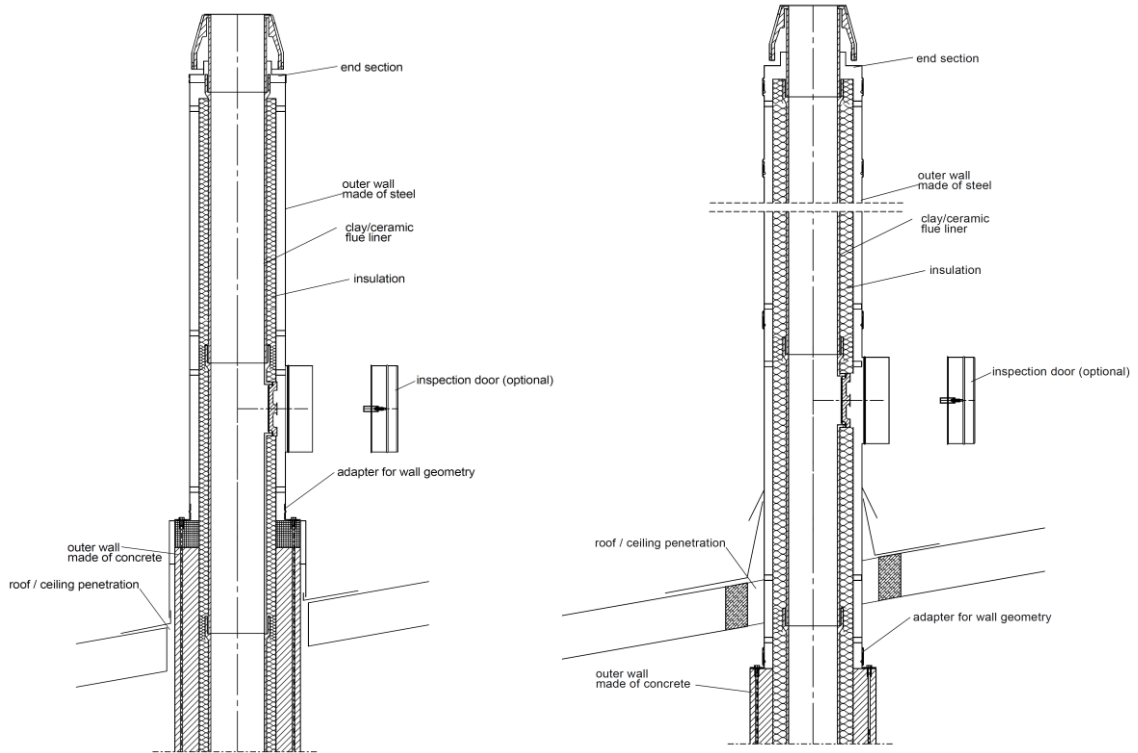

Figure 1.1.3: Chimney kit W3 G with extension by means of outer wall made of metal (Examples)

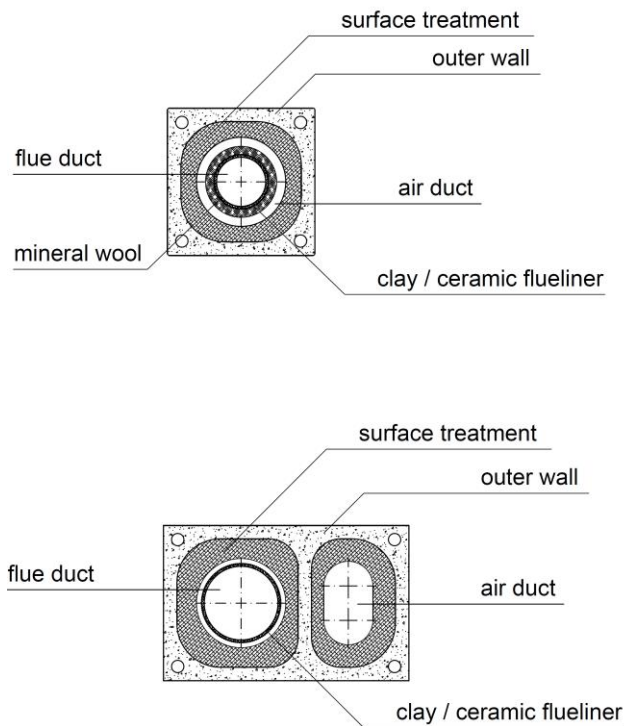

Figure 1.1.4: General cross section drawings for the use of concentric air-flue chimneys and side by side air flue chimneys (Examples).

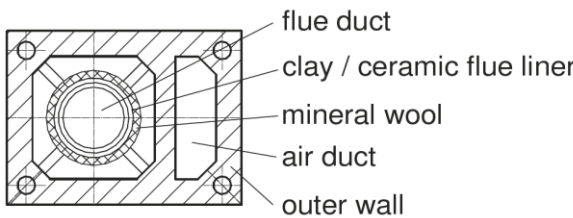
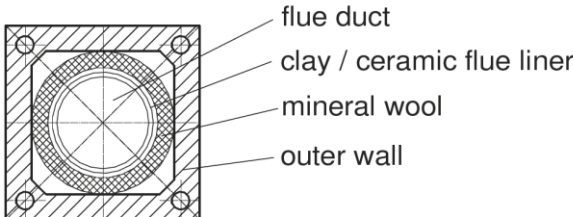
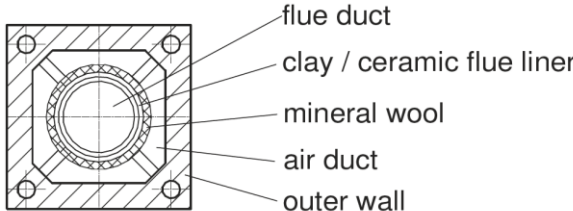

Figure 1.1.5: General cross section drawings for the use of concentric air-flue chimneys and side by side air flue chimneys (Examples)

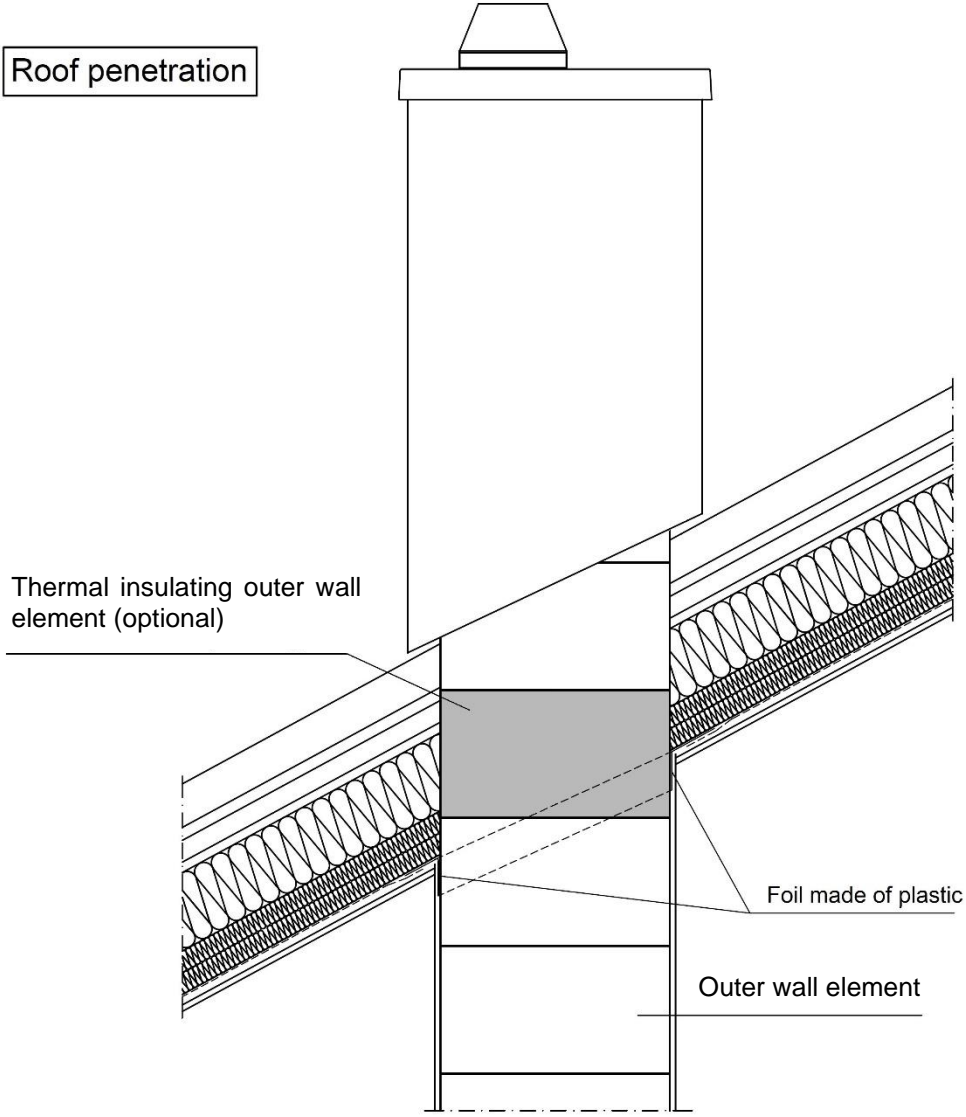

Figure 1.1.6: General drawing for the use of specific components for roof penetration (Example)

Floor ceiling

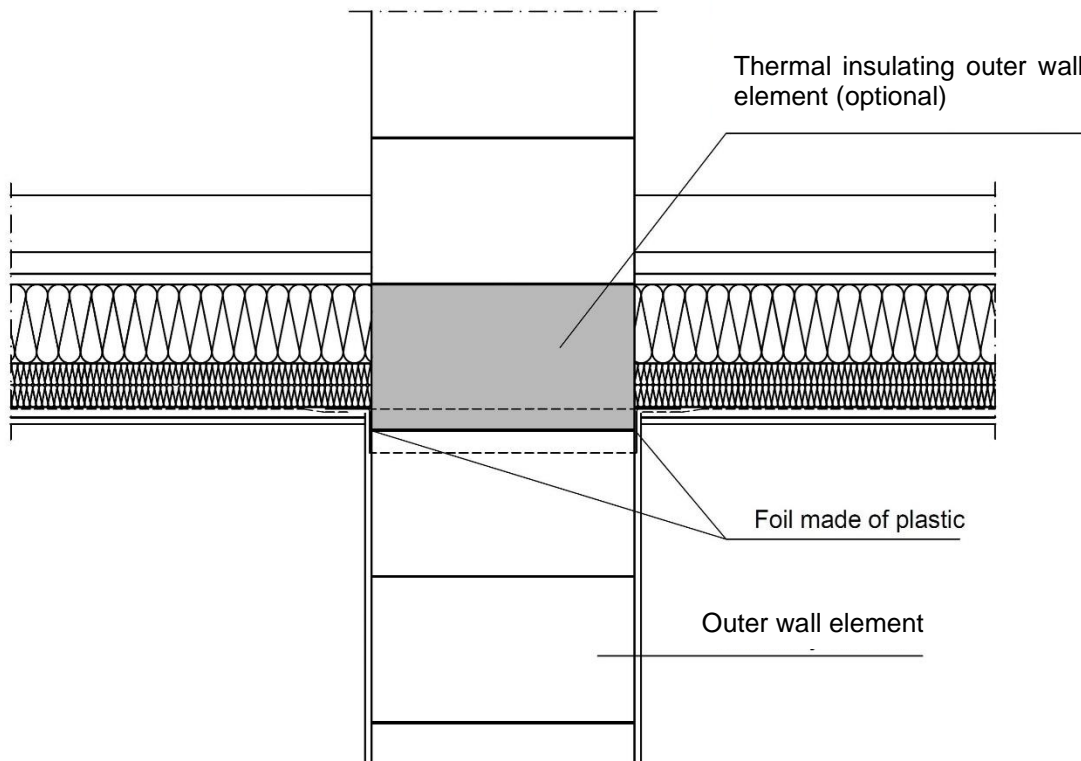

Figure 1.1.7: General drawing for the use of specific components for ceiling penetration (Example)

In general, elastomeric sealings are not part of the chimney kit W3 G, only in case of the classification P1 the inspection doors of the flue liner may include elastomeric sealings in order to achieve the requested tightness.

Elements for roof and ceiling penetration, depicted in Figures 1.1.6 and 1.1.7 respectively as example, are additional optional features to be assessed and to be delivered with the chimney kit W3 G for the concerned specific intended use. They are used together with the chimney kit W3 G in case the chimney kit W3 G should be used as suitable component in buildings with specific requirements regarding tightness of the building and air exchange rate (e.g., passive house).

This EAD is covering EAD 060001-00-0802 and EAD 060003-00-0802 and EAD 060008-00-0802, whereas in Clause 2.2.1 in this EAD a European assessment method regarding resistance to fire has been introduced.

The product is not fully covered by the following harmonised technical specifications:
EN 13063-1:2007, EN 13063-2:2007, EN 13063-3:2007

The chimney kit W3 G according to this EAD deviates from concerned standards due to its classification N1/P1 W3 Gxx, which is not covered by the concerned European harmonised standards.

In addition, the essential characteristics relevant for the use of the product in buildings with specific requirements regarding air tightness and minimum outer surface temperature are not dealt with in the concerned standards. Even the situation of possible change of outer wall within the system chimney and related essential characteristics given in Table 2.1.1 in this EAD is not addressed in the harmonised standards mentioned above.

Furthermore, the chimney kit W3 G according to this EAD deviates from concerned harmonised standards due to the optionally increased adjacent thermal insulation to be applied to walls and floors. This increased thermal insulation is not covered by the assessment method EN 13216-1:2004, referred to in EN 13063-1:2007 and EN 13063-2:2007. The maximum thickness, type and density of the increased thermal insulation to be applied to walls and floors (roofs) shall be stated in the scope of the ETA.

Justification for use of EN 13216-1:2004: Assessment methods given in EN 13216-1:2004 are used throughout in this EAD in order to comply with related assessment methods in hENs, referred to in this EAD, and related classes indicated in EN 1443:2003 and implemented in the concerned hENs cited in the OJEU.

Concerning product packaging, transport, storage, installation, maintenance, replacement and repair it is the responsibility of the manufacturer to undertake the appropriate measures and to advise his clients on the transport, storage, maintenance, replacement and repair of the product as he considers necessary.

It is assumed that the product will be installed according to the manufacturer's instructions (or in absence of such instructions) according to the usual practice of the building professionals.

Relevant manufacturer's stipulations having influence on the performance of the product covered by this European Assessment Document shall be considered for the determination of the performance and detailed in the ETA.

1.2 Information on the intended use(s) of the construction product

1.2.1 Intended use(s)

This EAD covers the following intended uses and (assembled) systems:

- System chimneys with clay/ceramic flue liner used to convey the products of combustion from appliances to the outside atmosphere under dry and wet conditions, operating under negative pressure/positive pressure.
- Optional: System chimneys serving more than one heating appliance (restricted to T400 and to solid fuel) in case of chimneys for roomsealed heating appliances (defined in the ETA) for N1.
- Optional: System chimneys in case of chimneys for roomsealed appliances for N1/P1 to be used as suitable component in buildings with specific requirements regarding tightness of the building and air exchange rate (e.g., passive house).

Note: The possible change of outer wall from non-metallic outer wall to outer wall made of metal (as depicted in Figure 1.1.3) is not relevant for system chimneys serving more than one heating appliance.

1.2.2 Working life/Durability

The assessment methods included or referred to in this EAD have been written based on the manufacturer's request to take into account a working life of the chimney kit W3 G for the intended use of 30 years when installed in the works (provided that the chimney kit W3 G is subject to appropriate installation (see 1.1)). These provisions are based upon the current state of the art and the available knowledge and experience. Appropriate evaluation is carried out by means of the assessment of the resistance to abrasion of the flue liner in relation to the working life.

When assessing the product, the intended use as foreseen by the manufacturer shall be taken into account. The real working life may be, in normal use conditions, considerably longer without major degradation affecting the basic requirements for works².

² The real working life of a product incorporated in a specific works depends on the environmental conditions to which that works is subject, as well as on the particular conditions of the design, execution, use and maintenance of that works. Therefore, it cannot be excluded that in certain cases the real working life of the product may also be shorter than referred to above.

The indications given as to the working life of the construction product cannot be interpreted as a guarantee neither given by the product manufacturer or his representative nor by EOTA when drafting this EAD nor by the Technical Assessment Body issuing an ETA based on this EAD, but are regarded only as a means for expressing the expected economically reasonable working life of the product.

1.3 Specific terms used in this EAD

For the purposes of this EAD, the specific terms and definitions given in EN 1443, EN 13063-1, EN 13063-2 and EN 13063-3 apply.

1.3.1 Chimney fitting

The term chimney fitting corresponds to similar terms (chimney junctions (EN 1457-1 and EN 1457-2), opening sections (EN 13063-1)).

1.3.2 Grout

Grout (in the sense of this EAD): Cement-bonded mortar, manufactured in plant.

2 ESSENTIAL CHARACTERISTICS AND RELEVANT ASSESSMENT METHODS AND CRITERIA

The testing of the chimney kit W3 G shall be carried out for as defined in the test sequences stated in Annex A for all essential characteristics the manufacturer intends to declare.

In case of change of outer wall by means of extension of the chimney kit W3 G with outer wall made of metal, for its assessment a testing chimney with outer wall made of metal is forming the basis for the assessment.

2.1 Essential characteristics of the product

Table 2.1.1 shows how the performance of the chimney kit W3 G is assessed in relation to the essential characteristics.

Table 2.1.1 Essential characteristics of the product and methods and criteria for assessing the performance of the product in relation to those essential characteristics

No	Essential characteristic	Assessment method	Type of expression of product performance
Basic Works Requirement 2: Safety in case of fire			
1	Resistance to fire from external to external	2.2.1	Level, Class
2	Resistance to fire from internal to external (sootfire resistance and thermal shock resistance)	2.2.2	Class "Gxx", Description
Basic Works Requirement 3: Hygiene, health and the environment			
3	Gas tightness/leakage	2.2.3	Class
4	Flow resistance	2.2.4	Level
5	Thermal resistance	2.2.5	Level
6	Durability/Condensate resistance	2.2.6	Class
7	Durability of gas tightness/ leakage against chemicals/corrosion Durability of compressive strength against chemicals	2.2.7	Class
8	Thermal and fluid dynamic characteristics of chimneys serving more than one heating appliance*	2.2.8	Description
9	Air tightness of the outer wall**	2.2.9	Level
10	Minimum outer surface temperature at defined ambient temperature**	2.2.10	Level
Basic Works Requirement 4: Safety and accessibility in use			
11	Maximum height	2.2.11	Level
12	Freeze/thaw resistance	2.2.12	Description
13	Durability in case of change of outer wall***	2.2.13	Description
<p>*In case of covering the intended use serving more than one roomsealed heating appliance and pressure class N1. **For specific intended use in buildings with specific requirements regarding tightness of the building and air exchange rate. ***In case of a non-metallic outer wall when the chimney kit W3 G may be extended by means of an outer wall made of metal, whereas the flue liner is continued for the whole kit.</p>			

2.2 Methods and criteria for assessing the performance of the product in relation to essential characteristics of the product

This chapter is intended to provide instructions for TABs. Therefore, the use of wordings such as “shall be stated in the ETA” or “it has to be given in the ETA” shall be understood only as such instructions for TABs on how results of assessments shall be presented in the ETA. Such wordings do not impose any obligations for the manufacturer and the TAB shall not carry out the assessment of the performance in relation to a given essential characteristic when the manufacturer does not wish to declare this performance in the Declaration of Performance.

Testing will be limited only to the essential characteristics which the manufacturer intends to declare. If for any components covered by harmonised standards or European Technical Assessments the manufacturer of the component has included the performance regarding the relevant characteristic in the Declaration of Performance, retesting of that component for issuing the ETA under the current EAD is not required.

2.2.1 Resistance to fire from external to external

Purpose of the assessment

Assessment shall be done in order to express the resistance to fire from external to external of the outer wall of the assembled chimney kit W3 G.

Assessment method

The resistance to fire from external to external of the assembled chimney kit W3 G shall be assessed according to EN 1366-13.

In case of change of outer wall by means of extension of the chimney kit W3 G with an outer wall made of metal, in the assessment, each of the outer walls shall be assessed in a separate test.

Expression of results

The assessed resistance to fire from external to external of the assembled chimney kit W3 G shall be stated in the ETA in terms of minutes.

In case of change of outer wall by means of extension of the chimney kit W3 G with an outer wall made of metal, for each type of outer wall, the outcome shall be stated in the ETA.

2.2.2 Resistance to fire from internal to external (sootfire resistance and thermal shock resistance)

Purpose of the assessment

For the chimney kit W3 G, the concerned class and related minimum distance to combustible materials shall be assessed.

Assessment method

For the assessment EN 13063-1, Clauses 5.2.1.2 and 5.2.1.3, apply.

In case of use of upper cleaning/inspection doors as part of the kit to be assessed they shall be included in the assessment. The surface temperature shall be assessed according to EN 13063-1, Clause 5.4. Referring to EN 13063-1, Clause 5.4, the temperature at the outer surface of the cleaning and inspection doors shall not increase more than 140 K. The same applies for closing devices (in case of more than one heating appliances). For closing devices (in case of more than one heating appliance), in case of separate assessment EN 13063-1, Annex A.2.5, applies for assessment of leakage rate, whereas the maximum leakage rate as defined in Table 2 in EN 13063-1 applies.

Regarding the restriction of the relative movement of the flue liner, the upper cleaning/inspection door shall be included in the assessment when part of the kit to be assessed.

In case of classification P1, the inspection door with elastomeric sealing shall be included in the assessment.

In case of including a covering made of concrete, it shall be included in the assessment stated above concerning the occurrence of visible cracks.

If elements for ceiling penetration are part of the kit, they shall be included in the assessment, whereas they are not considered relevant for the assessment of distance to combustible materials for the classification Gxx.

Depending on the applicability of the ceiling element for to the product to be assessed, it shall be considered in one of the following constellations according to EN 13216-1:

- application with separate ceiling element in zone C
- application in ceiling situated between zone B and C
- application in ceiling situated between zone A and B

For the assessment of the compatibility of the ceiling element with the occurring temperature on the outer wall, the positions for measurements of surface temperatures as defined in EN 13216-1, Clause 5.7.4.4, shall be used.

In addition and optional, the following testing arrangements with respect to increased thermal insulation, deviating from EN 13216-1, are of relevance: on the test rig, as defined in 13216-1, Figure 1, increased thermal insulation is applied to the walls and also under or above the floor between zone A-B and/or B-C (including definition of minimum distances to combustible materials, depending on the classification of the chimney element envisaged).

In case of applying hot gas velocity according to EN 1859 instead of EN 13216-1, Clause 5.7.2.2, this shall be stated in the ETA. It is exclusively related to the assessment of minimum distance to burnable materials in case of increased thermal insulation.

Expression of results

The sootfire resistance and the distance between the outer surface of the chimney kit W3 G and the adjacent combustible material shall be stated as G(xx), where G is the sootfire resistance class for chimneys with sootfire resistance and xx is the minimum distance in mm. For the minimum distance, the maximum value resulting of the assessment given in EN 13063-1, Clause 5.2.1, taking into account the conditions stated above, is relevant.

In case of assessment with increased thermal insulation, the dimensions [mm] and location of the applied thermal insulation shall be given.

In case of including a covering made of concrete in the assessment, it shall be stated in the ETA if visible cracks occur or not. In case of elements for ceiling penetration are included, they shall be defined in the ETA, including whether they do cope with the occurring temperature at the outer surface of the chimney kit W3 G or not.

2.2.3 Gas tightness/leakage

Purpose of the assessment

For the chimney kit W3 G, gas tightness/leakage shall be assessed.

Assessment method

The gas tightness/leakage shall be assessed according to EN 13063-1, Clause 5.3.1.

In case upper cleaning/inspection doors are part of the kit to be assessed they shall be included in the assessment.

In addition, in case of classification P1 the following applies:

In order to assess the envisaged positive pressure class P1, EN 13063-2, Clause 5.3.1 applies, whereas the elastomeric sealing of the inspection door of the flue liner shall be included. In addition, assessment shall be done as stated in EN 13063-1, Clause 5.3.1, in order to cover the envisaged resistance to sootfire.

It shall also be assessed, whether the resulting temperature of the elastomeric sealing is not exceeding the maximum allowable temperature according to EN 14241-1 as stated in EN 13063-2, Clause 5.3.2.1.

Expression of results

The pressure class (N1/P1) shall be stated in the ETA.

Note: The functionality of the inspection door for the classification of the chimney kit W3 G envisaged is given when the occurred temperature at the elastomeric sealing does not exceed the temperature stated above. In the ETA this is included in the class “P1”.

2.2.4 Flow resistance

Purpose of the assessment

The flow resistance to be assessed for the chimney kit W3 G is dealt with by means of the flow resistance of the relevant components (including the adapter and extension in case of change of outer walls from concrete or clay ceramic to metal) to be addressed in the ETA for the individual product.

Assessment method

The flow resistance shall be assessed according to EN 13063-1, Clause 5.3.3, and in case of air flue system chimney, EN 13063-3, Clause 5.7.1.

Expression of results

The flow resistance of the relevant parts shall be stated in the ETA by means of mean roughness r or ζ -values.

2.2.5 Thermal resistance

Purpose of the assessment

The thermal resistance of the chimney kit W3 G shall be assessed as R_{yy} , in relation to the inner diameter of the flue liner, including the components as foreseen for the product to be assessed.

In addition, if foam concrete is part of the product to be assessed, its durability shall be assessed.

Assessment method

2.2.5.1 Assessment of thermal resistance

The thermal resistance shall be assessed according to EN 13063-1, Clause 5.2.3.

In case of use of foam concrete as surface treatment of the outer wall, the following applies for the assessment of the thermal resistance:

- In case of assessment of thermal resistance R_{yy} by means of testing as indicated in EN 13063-1, Clause 5.2.3, in the test specimen the foam concrete as surface treatment of the outer wall shall be included.

In case of assessment of the thermal resistance R_{yy} by means of calculation as indicated in EN 13063-1, Clause 5.2.3, the thermal conductivity (needed as input for the calculation of R_{yy}) is assessed as stated in EN 12667, whereas the temperature, as indicated in Clause 5.2.3 in EN 13063-1, shall be considered in the assessment. For the test specimens, EN 12667, Clause 6.3.2 applies. The dimensions of the test specimen shall be at least 200 mm x 200 mm and with thickness as used in the outer wall element. Prior to the test, the specimens shall be dried until constant mass at 105° C.

Note: The used instrument needs to cover a hot plate temperature $\geq 200^\circ$ C.

2.2.5.2 Durability of the foam concrete

In addition to the assessment of the thermal resistance, the assessment of durability of the foam concrete according to the procedure stated below shall be carried out, if it is part of the product composition:

The durability of the foam concrete shall be assessed as given in Clause 5.1.5.3 in EN 13063-1 for the thermal insulation, with temperature of at least 300 °C. Test specimen shall be prepared as defined in Clause A.2.1 in EN 13063-1 of hardened foamed concrete and with thickness as used in the outer wall elements.

Note: The bulk density for the foam concrete shall be assessed according to EN 772-13.

Expression of results

The thermal resistance (assessment according to Clause 2.2.5.1) shall be stated in the ETA in the following way: R_{yy} (in relation to the inner diameter of the flue liner), where yy is the value in square meters Kelvin per Watt multiplied by 100, rounded to the nearest integer.

For the durability of foamed concrete (assessment according to Clause 2.2.5.2), it shall be stated “durable”/“not durable”, bulk density can be given as supporting information.

2.2.6 Durability/Condensate resistance

Purpose of the assessment

For the envisaged classification W3 G of the chimney kit W3 G the condensate resistance, dealt with in harmonised standards as durability aspect, shall be assessed.

Assessment method

The condensate resistance shall be assessed according to EN 13216-1, Clause 5.5, except assessment of changing in weight of the test specimen or components according to Clauses 5.5.3 and 5.5.5.

The vapour saturation resistance (condensate resistance in the meaning of EN 13063-2) of the assembled system shall be assessed according to EN 13216-1, Clause 5.6, as stated in EN 13063-2, Clause 5.3.2.1.

Description that no vapour saturation in any part of the kit and no appearance of water on the outside of the test specimen of fittings or chimney sections occur after visual inspection of the assembled test specimen.

In case of use of upper cleaning/inspection doors as part of the kit to be assessed they shall be included in the assessment, whereas according to EN 13063-2, Clause 5.4, no water shall occur at the outside of the cleaning and inspection door.

In case of elastomeric sealings used in the inspection doors for classification for P1:

In addition, it shall be assessed whether at the elastomeric sealing, if any, condensate occurs. According to EN 13063-2, Clause 5.4, no water shall occur.

Expression of results

If the conditions stated above are met, the condensate resistance class “W” shall be stated in the ETA. Otherwise, the product falls beyond the scope of this EAD.

2.2.7 Durability of gas tightness/leakage against chemicals/corrosion Durability of compressive strength against chemicals

Purpose of the assessment

The assessment is composed of the following: Assessment of sootfire resistance, assessment of condensate resistance and assessment of the jointing material of the flue liner.

Assessment method

Assessment of sootfire resistance: Clause 2.2.2 in this EAD applies.

Assessment of condensate resistance: Clause 2.2.6 in this EAD applies.

For the assessment of jointing material made of mortar for the flue liner the following applies:

Compressive strength according to EN 13063-2, Clause 5.1.3.1.2, Water resistance according to EN 13063-2, Clause 5.1.3.1.3, and acid resistance according to EN 13063-2, Clause 5.1.3.1.4.

For the assessment of jointing material made of glass fibre fabrics for the flue liner the following applies:

- Acid resistance according to EN 13063-2, Clause A.2.2.5.

Expression of results

If the requirements stated above are fulfilled, the chimney shall be classified as corrosion resistant class "3", otherwise the product falls beyond the scope of this EAD.

2.2.8 Thermal and fluid dynamic characteristics of chimneys serving more than one heating appliance

Purpose of the assessment

Assessment of the maximum number of roomsealed heating appliances connected to the chimney kit W3 G, depending on the minimum distance between the heating appliances and the minimum height of the chimney above the last heating appliance.

Assessment method

Assessment shall be done by means of testing. Various service situations (scenarios 1 to 4) shall be considered as stated below.

Test equipment:

The test configuration shall include the number of heating appliances for which the performance of the chimney kit W3 G shall be assessed and shall also include the pressure equalizing opening. The maximum number of heating appliances shall be limited to 1 per floor. The height above the uppermost heating appliance shall be defined in respect to the service pressure according to Clause 6.4 in EN 13240 or Clause 4.7.4 in EN 16510-2-1. Note: For the use of EN 16510-2-1, Article 17 (5) of Regulation (EU) No 305/2011 applies.

The roomsealed heating appliance connected to the testing chimney shall be defined by the following conditions which shall be stated in the ETA:

- Service pressure (minimum values; Pa),
- Declaration of efficiency (minimum value; %),
- Proper self-closing of opening door of heating appliance,
- Leakage rate of $\leq 2\text{m}^3/\text{h}$ (testing pressure: 10 Pa).

Test execution:

The relevant parameter for the execution of the test is the minimum amount of loading material (solid fuel) according to EN 13240 or EN 16510-1, Clause A.4.2.2 respectively, whereas the burning duration t_b is defined by 45 minutes. The ignition of the burning material shall be conducted one after another, starting in cold condition.

The following service situations shall be tested, depending of the number of heating appliances:

Scenario no. 1: All heating appliances are operating by operating negative pressure of 0 Pa in related testing rooms.

Scenario no. 2: All heating appliances are operating by operating negative pressure of at least 8 Pa in related testing rooms.

Scenario no. 3: The highest heating appliance is operating by operating negative pressure of 0 Pa in the related testing room.

Scenario no. 4: Initial burning of the fuel in the lowest heating appliance when the door of the penultimate heating appliance of the test set (in case of more than two heating appliances) or the upper (in case of two heating appliances) is still open; operating negative pressure of 0 Pa, with open pressure equalizing opening.

Whereas:

For scenario no. 1:

All heating appliances are allowed to show a decrease in efficiency to a value of not less than 80 % of their stated efficiency (values measured during the nominal heat output test).

For scenario no. 2:

All heating appliances are allowed to show a decrease in efficiency to a value of not less than 80 % of their stated efficiency (values measured during the nominal heat output test).

No outflow of combustion products in case of opening of the door of the heating appliance.

For scenario no. 3:

All heating appliances are allowed to show a decrease in efficiency to a value of not less than 80 % of their stated efficiency (values measured during the nominal heat output test).

For scenario no. 4:

No overflow of combustion product in the air duct.

For all scenarios, the following applies:

The efficiency of the heating appliance shall be calculated according to EN 13240, Clause A.6.2.1, or 16510-1, Clause A.6.2.1. The needed values for the calculation shall be measured in the connecting elements of the heating appliances (CO or CO₂ and flue gas temperature).

Conditions for the assessment of the maximum number of heating appliances:

- Each of the heating appliances shall be able to work, independent of service conditions of the other heating appliances,
- Influence of opening of doors of individual heating appliance to proper functioning of other heating appliances,
- Influence of pressure equalizing opening to service conditions of heating appliances (relationship between service pressure and efficiency),
- Maintenance of negative pressure in all heating rooms for all service conditions (e.g., appropriate devices like door contact switch).
- All heating appliances shall show in all testing situations a heat output of not less than 80 % of the nominal performance. The fulfilment of this condition is ensured by applying a pressure equalising opening.
- Proper functioning of the pressure equalizing opening.

Depending on the outcome of the assessment under consideration of the given conditions, the product is either applicable for serving more than one heating appliance or not.

Expression of results

If applicable, the maximum number of heating appliances and the related distances between the heating appliances in [m] and minimum height above the last heating appliance in [m] shall be stated in the ETA.

2.2.9 Air tightness of the outer wall

Purpose of the assessment

Assessment is done for an outer wall unit, composed of elements or as prefabricated unit, of a chimney kit W3 G for the contribution of the chimney kit W 3G to the air tightness of buildings where specific requirements for buildings regarding air tightness apply.

Assessment method

Assessment of the tightness shall be carried out before and after thermal load of the chimney kit W3 G as defined in Clause 2.2.2 in this EAD, whereas the assessment shall be done on separate specimens. For each of the tests one specimen shall be tested. As test specimen a chimney unit, including all parts of the product to be assessed (e.g., cleaning and inspection doors, if part of the product composition), shall be used.

Testing equipment

The testing equipment shall be such that the installed test specimen can be assessed applying positive and negative pressure of 50 Pa. For accuracies Clause 4.2 in EN ISO 9972 apply.

The test assembly, as defined in Figure 2.2.9.1, consists of a chamber with a sealable opening on one side, enclosing the test specimen.

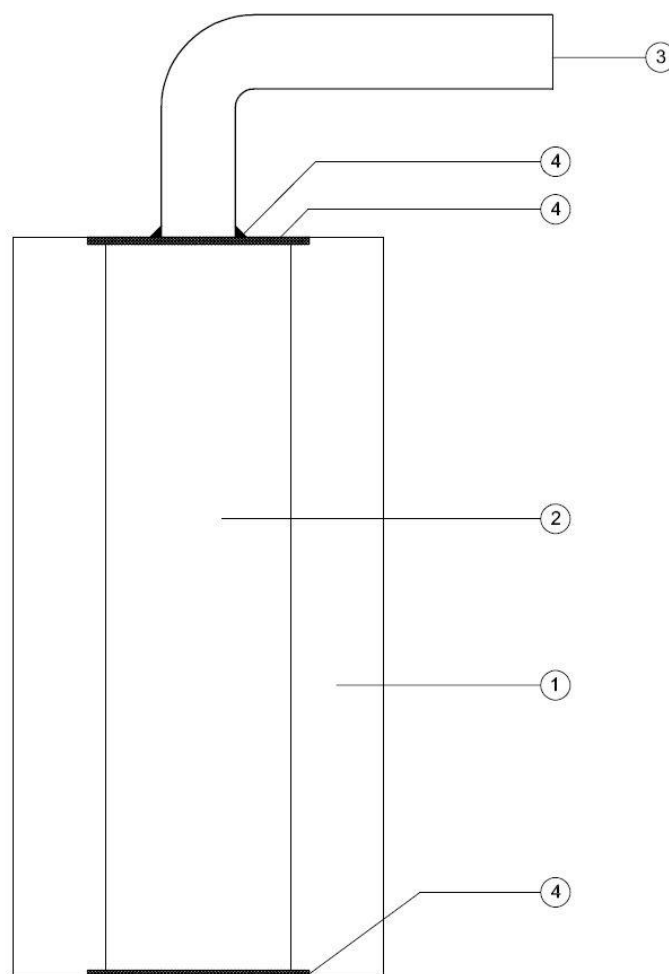

Legend:

- 1 pressure chamber
- 2 test specimen
- 3 connection to ambient pressure
- 4 sealing

Figure 2.2.9.1

Preparation of test specimen

The test specimen shall be sealed on both ends. In addition, a tight connection between the inner surface of the outer wall and the ambient atmosphere is established.

Test execution:

Testing shall be done by applying the fan pressurised method (see also EN ISO 9972) on the outer and inner surface of the outer wall of the test specimen.

During testing the testing pressure of +/- 50 Pa applied to the outer surface shall be maintained constant. The duration of the application of pressure for both levels (positive and negative) shall be sufficient to allow the test pressure to stabilise before the air volume flow shall be measured. The related air volume flow in order to establish constant pressure shall be measured and recorded.

The measurement shall be done at ambient temperature (10 °C to 30 °C).

Test report

The test report shall include:

- A detailed product description and information on treatment of the outer surface, if any
- Measured air volume flow [m³/h] for both negative and positive pressure
- Observations of unusual occurrences, if any.

Expression of results

In the ETA the air tightness shall be expressed as average leakage rate [m³/hm]. The average leaking rate before and after thermal load shall be expressed separately.

2.2.10 Minimum outer surface temperature at defined ambient temperature

Purpose of assessment

Assessment shall be done for the chimney kit W3 G for use within buildings where specific requirements for the building and its elements regarding air exchange apply.

Assessment method

Assessment shall be done on a representative unit, taking into account the composition of the product to be covered in the ETA. Whereas for calculation the thermal flow simulation by means of consideration of thermal bridges at defined indoor and outdoor temperature applies. The assumed outdoor and indoor ambient temperatures shall be stated in the ETA. As input values for the software calculation, the material data of components and outside ambient and inside ambient temperature have to be considered.

The 2-D and/or 3-D software used for the calculation of thermal flow simulation by means of consideration of thermal bridges at defined inner temperature of the unit at inner surface (see above) for the outer surface temperature shall be validated according to EN ISO 10211, Annex C. For 2D-calculation, case 1 and 2, for 3D-calculation cases 1 to 4 of Annex C of EN ISO 10211 apply. The test report applied for the assessment shall include confirmation on the validation (reference to EN ISO 10211) and the name of the used program.

Expression of results

The resulting minimum outer surface temperature of the outer wall and the assumed indoor and outdoor ambient temperature shall be given in the ETA.

The program used for calculation shall be addressed in the ETA.

2.2.11 Maximum height

Purpose of the assessment

The maximum height of the chimney kit W3 G shall be assessed by means of the assessment of its components outer wall, types of flue liners and their jointing materials. This is in order to assess the minimum resulting maximum height on basis of the individual assessments.

Assessment method

For assessment of the maximum height of the inner liner (by means of maximum load for opening sections and pressure equalizing openings, if part of the product composition) EN 13063-2, Clause 5.1.2 and EN 13063-3, Clause 5.3 apply respectively, with the following reservation: The applied load shall be increased until failure and the maximum load “F_{OP}” in [kN] shall be recorded. The maximum height “H_{IL}” in [m] of the inner liner shall be calculated as follows:

$$H_{IL} = (100 * F_{OP}) / (\chi_I * G_I)$$

where

F _{OP}	Maximum load of the opening section in [kN]
χ _I	Safety factor = 5
G _I	Weight per meter [kg/m] of the inner liner
H _{IL}	Maximum height of the inner liner [m]

For mortar jointing for flue liner EN 13063-2, Clause 5.1.3.1.2 applies.

For jointing material for outer wall made of concrete or clay/ceramic EN 13063-1, Clause 5.1.7 applies.

In case of outer wall elements made of prefabricated units made of calcium silicate boards, for the jointing material EN 998-2, Clause 5.4.1 applies.

For assessment of the maximum height of the outer wall made of concrete or prefabricated units made of calcium silicate boards, EN 12446, Clause 8.4 applies. For the test load ANNEX A.11 of EN 1857 applies. The compressive strength “σ” in [N/mm²] shall be measured before and after thermal load. In case of need of test specimens with smaller dimensions (see ANNEX A.8.2.1 of EN 1857), they shall be taken from the corner situated on the same side as the flue duct, if a side-by-side air flue chimney is part of the kit. Surface treatment, if part of the product composition, shall not be considered.

The maximum possible height “H_{OW.Concrete}”, in [m], of the outer wall element is calculated as follows:

$$H_{OW.Concrete} = \text{MIN} \{ H_{OWb.th}; H_{OWa.th} \}$$

where

$$H_{OWb.th} = (\sigma_{b.th} * A) / (10 * \chi_{b.th} * G_{OW.Concrete}) = \text{Maximum possible height before (b.th) thermal load in [m]}$$

$$H_{OWa.th} = (\sigma_{a.th} * A) / (10 * \chi_{a.th} * G_{OW.Concrete}) = \text{Maximum possible height after (a.th) thermal load in [m]}$$

σ_{b.th/a.th} compressive strength before (b.th) and after (a.th) thermal load in [N/mm²]

A Cross sectional area of outer wall element in [mm²]

χ_{b.th/a.th} Safety factor = 4 before (b.th) and = 3 after (a.th) thermal load

G_{OW.Concrete} Weight per meter [kg/m] of the outer wall

For assessment of the outer wall made of clay/ceramic EN 13069, Clause 6 applies, with the following deviation: The applied load shall be increased until failure and the maximum load “F_{OW.c}” in [kN] shall be recorded. The maximum height “H_{OW.c}” in [m] of the outer wall shall be calculated as follows:

$$H_{OW.c} = (100 * F_{OW.c}) / (\chi_C * G_{OW.c})$$

where

F_{OW.c} Maximum load of the clay/ceramic outer wall in [kN]

χ_C Safety factor = 5

G_{OW.c} Weight per meter [kg/m] of the clay/ceramic outer wall

H_{OW.c} Maximum height of the clay/ceramic outer wall [m]

For an outer wall made of metal EN 13063-1, Annex B applies with the following reservations: The maximum load shall be assessed as described in Clause 4.1.1.2 of EN 1859 for an unknown maximum load. The maximum height “H_{OW.M}” in [m] of the outer wall shall be calculated as follows:

$$H_{OW.M} = (100 * F_{OW.M}) / (\chi_M * G_{OW.M})$$

where

F _{OW.M}	Maximum load of the metal outer wall in [kN]
χ _M	Safety factor = 5, according to Annex B.3 of EN 13063-1
G _{OW.M}	Weight per meter [kg/m] of the metal outer wall
H _{OW.M}	Maximum height of the metal outer wall [m]

Whereas in case of an outer wall made of metal it is presumed that the outer wall is operating independent from the flue liner. In case of change of the outer wall as indicated in Chapter 1.1 of this EAD the weight of the extension of the outer wall, including the adapter, shall be taken into account in the assessment of the height of the outer wall made of concrete/clay/ceramic. For the extension itself, made of metal, Annex B in EN 13063-1, applies.

Expression of results

The maximum height of the assembled chimney kit W3 G shall be expressed in the ETA in [m], whereas it is the outcome of the overall assessment of maximum heights of flue liners and outer wall. As far as compressive strength is the outcome of the assessment according to the relevant standard, mentioned above, it shall be stated in the ETA as well. In case a thermal insulating outer wall element is part of the product composition, this shall be taken into account.

Note: In the assessment the type of chimney base shall be taken into account.

2.2.12 Freeze thaw resistance

Purpose of the assessment

Freeze-thaw resistance of the chimney kit W3 G is related to the assessment of the flue liner of the chimney kit W3 G and of the covering of the flue liner, made of concrete, if part of the kit.

Assessment method

For outer walls made of concrete, including covering made of concrete, if any, and clay/ceramic and flue liner according to EN 1457-2, the freeze thaw resistance shall be assessed according to the assessment method given in EN 13063-1, Clause 5.5.

Outer walls made of metal are considered freeze thaw resistant according to EN 1856-1, Clause 6.7.3.

Expression of results

In the ETA the following shall be stated: Criteria met / Criteria not met.

2.2.13 Durability in case of change of outer wall

Purpose of the assessment

The assessment of durability in case of change of outer walls from concrete or clay ceramic to metal is carried out in order to assess the behaviour of outer walls made of concrete or clay ceramic due to such change.

Assessment method

Assessment shall be done on a unit consisting of an adapter element placed on an outer wall made of concrete or clay/ceramic and a section of an outer wall made of metal, whereas for the assessment according to in EN 13216-1, Clause 5.7.3.1, zone C, according Figure 1 of EN 13216-1, is relevant. Conditions in relation to thermal insulation as detailed in Clause 2.2.2 in this EAD shall be taken into account accordingly.

Assessment shall be done by means of heat stress test and the sootfire test carried out according to EN 13216-1, Clause 5.7.5, for temperature class T400 and T600 respectively, depending on the classification envisaged.

It shall be assessed whether visual defects occur after carrying out the tests at the outer wall made of concrete and clay/ceramic. Furthermore, based on temperatures recorded for the outer walls, it shall be assessed whether they may result in inadequate behaviour of the chimney kit W3 G in relation to this change of the outer walls. This means that the occurring maximum temperature on the surface of the adapter shall not be higher than for the outer wall made of metal above.

Expression of results

In the ETA the following shall be stated: Durable/ Not durable.

3 ASSESSMENT AND VERIFICATION OF CONSTANCY OF PERFORMANCE

3.1 System(s) of assessment and verification of constancy of performance to be applied

For the products covered by this EAD the applicable European legal act is Commission Decision 95/467/EC (EU), amended by 2001/596/EC (EU), 2002/592/EC (EU) and 2010/679/EU.

The system is 2+.

3.2 Tasks of the manufacturer

The cornerstones of the actions to be undertaken by the manufacturer of the kit in the procedure of assessment and verification of constancy of performance are laid down in Table 3.2.1 to Table 3.2.4.

The manufacturer (regarding the components he buys from the market with DoP) shall take into account the Declaration of Performance issued by the manufacturer of that component. No retesting is necessary.

Table 3.2.1 Control plan for the manufacturer; cornerstones

No	Subject/type of control	Test or control method	Criteria, if any	Minimum number of samples	Minimum frequency of control
Factory production control (FPC) [including testing of samples taken at the factory in accordance with a prescribed test plan]					
1	Components covered by relevant harmonised technical specification				
1.1	Components where all needed characteristics are covered by the DoP	Check of delivery documents	Conformity with the order	Testing is not required	Each delivery
1.2	Components where not all needed characteristics are covered by the DoP	According to relevant harmonised technical specification*	According to relevant harmonised technical specification*	According to relevant harmonised technical specification*	According to relevant harmonised technical specification*
* Only applies for the characteristic which is not covered by relevant DoP, otherwise No. 1.1 applies.					
2	Outer wall				
2.1	Outer wall made of units of calcium silicate boards	According to Control plan	According to Control plan	According to Control plan	According to Control plan
2.2	Jointing material in case of calcium silicate boards: Compressive strength	According to Control plan	According to Control plan	According to Control plan	According to Control plan
2.3	Surface treatment (foamed concrete):				
2.3.1	Bulk density	EN 772-13	According to Control plan	3	1 per month
2.3.2	Composition	According to Control plan	According to Control plan	According to Control plan	According to Control plan
3	Thermal insulating outer wall element				
3.2	Compressive strength	According to Control plan	According to Control plan	According to Control plan	According to Control plan
4	Chimney base				

No	Subject/type of control	Test or control method	Criteria, if any	Minimum number of samples	Minimum frequency of control
4.1	Outer wall (prefabricated chimney base)				
4.1.1	Compressive strength	According to Control plan	According to Control plan	According to Control plan	According to Control plan
4.2	Plate of chimney base				
4.2.1	Bulk density in case of concrete	EN 12390-7	EN 206, Cl. 5.5.2	3	Each charge
4.3	Suspension device made of metal				
4.3.1	Dimensions	Measurement by means of gauge	According to Control plan	1 per diameter	Each delivery
4.3.2	Material	According to Control plan	According to Control plan	1 per diameter	Each delivery
5	Upper cleaning and inspection door for designation W3Gxx (not covered by EN 13063-1, EN 13063-2)				
5.1	Cleaning and inspection door of the outer wall:				
5.1.2	Functioning ability: Leakage	According to Control plan	According to Control plan	10	Each delivery
5.2	Cleaning and inspection door of flue liner				
5.2.1	Leakage	According to Control plan	According to Control plan	3	Once a year
5.2.2	Condensate resistance	According to Control plan	According to Control plan	3	Once a year
6	Elements of the ceiling penetration				
6.1	Material quality	According to Control plan	According to Control plan	According to Control plan	According to Control plan
6.2	Dimensions	According to Control plan	According to Control plan	According to Control plan	According to Control plan
7	Adapter for outer wall geometries in case of change of outer walls				
7.1	Geometry including thickness	By means of gauge; visual check	According to Control plan	10 % of each delivery	10 % of each delivery
7.2	Material quality	According to Control plan	According to Control plan	According to Control plan	Each delivery
8	Complete Kit				
8.1	Conformity to the specification drawings e.g. correct elements, dimensions, pre assembly.	According to Control plan	According to Control plan	According to Control plan	Each delivery
8.2	General aspects EN 13063-1, EN 13063-2	EN 13063-1, EN 13063-2 Details laid down in control plan	EN 13063-1, EN 13063-2 Details laid down in control plan	Each kit	Each kit

3.3 Tasks of the notified body

The cornerstones of the actions to be undertaken by the notified body in the procedure of assessment and verification of constancy of performance for the chimney kit W3 G are laid down in Table 3.3.1.

Table 3.3.1 Control plan for the notified body; cornerstones

No	Subject/type of control	Test or control method	Criteria, if any	Minimum number of samples	Minimum frequency of control
Initial inspection of the manufacturing plant and of factory production control <i>(for systems 1+, 1 and 2+ only)</i>					
1	Notified Body will ascertain that the factory production control with the staff and equipment are suitable to ensure a continuous and orderly manufacturing of the "chimney kit W3 G".	Verification of the complete FPC as described in the control plan agreed between the TAB and the manufacturer	According to Control plan	According to Control plan	When starting the production of a new line
Continuous surveillance, assessment and evaluation of factory production control <i>(for systems 1+, 1 and 2+ only)</i>					
2	The Notified Body will ascertain that the system of factory production control and the specified manufacturing process are maintained taking account of the control plan.	Verification of the controls carried out by the manufacturer as described in the control plan agreed between the TAB and the manufacturer with reference to the raw materials, to the process and to the product as indicated in Table 3.2.1.	According to Control plan	According to Control plan	1/year

4 REFERENCE DOCUMENTS

EN 206:2013+A1:2016+A2:2021 “Concrete - Specification, performance, production and conformity”

EN 445:2007 “Grout for prestressing tendons — Test methods”

EN 772-13:2000 “Methods of test for masonry units — Part 13: Determination of net and gross dry density of masonry units (except for natural stone)”

EN 998-1:2016 “Specification for mortar for masonry - Part 1: Rendering and plastering mortar”

EN 998-2:2016 “Specification for mortar for masonry — Part 2: Masonry mortar”

EN 1015-3:1999+A1:2004+A2:2006 “Methods of test for mortar for masonry — Part 3: Determination of consistence of fresh mortar (by flow table)”

EN 1366-13:2019 “Fire resistance tests for service installations - Part 13: Chimneys”

EN 1443:2003 “Chimneys — General requirements”

EN 1457-1:2012 “Chimneys - Clay/ceramic flue liners — Part 1: Flue liners operating under dry conditions - Requirements and test methods”

EN 1457-2:2012 “Chimneys - Clay/ceramic flue liners — Part 2: Flue liners operating under wet conditions - Requirements and test methods”

EN 1856-1:2009 “Chimneys - Requirements for metal chimneys - Part 1: System chimney products”

EN 1859:2009+A1:2013 “Chimneys. Metal chimneys. Test methods”

EN 10204:2004 “Metallic products — Types of inspection documents”

EN 12390-7:2019+AC:2020 “Testing hardened concrete — Part 7: Density of hardened concrete”

EN 12446:2011 “Chimneys - Components — Concrete outer wall elements”

EN 12617-4:2002 “Products and systems for the protection and repair of concrete structures — Test methods — Part 4: Determination of shrinkage and expansion”

EN 12667:2001 “Thermal performance of building materials and products — Determination of thermal resistance by means of guarded hot plate and heat flow meter methods — Products of high and medium thermal resistance”

EN 13055:2016 “Lightweight aggregates”

EN 13063-1:2005+A1:2007 “Chimneys — System chimneys with clay/ceramic flue liners — Part 1: Requirements and test methods for sootfire resistance”

EN 13063-2:2005+A1:2007 “Chimneys — System chimneys with clay/ceramic flue liners — Part 2: Requirements and test methods under wet conditions”

EN 13063-3:2007 “Chimneys — System chimneys with clay/ceramic flue liners — Part 3: Requirements and test methods for air flue system chimneys”

EN 13069:2005 “Chimneys – Clay/ceramic outer walls for system chimneys – Requirements and test methods”

EN 13162:2012+A1:2015 Thermal insulation products for buildings - Factory made mineral wool (MW) products - Specification

EN 13216-1:2004 “Chimneys — Test methods for system chimneys — Part 1: General test methods”

EN 13240:2001+A2:2004+AC:2007 “Roomheaters fired by solid fuel — Requirements and test methods”

EN 13384-1:2015+A1:2019 “Chimneys — Thermal and fluid dynamic calculation methods — Part 1: Chimneys serving one appliance”

EN 13395-2:2002 “Products and systems for the protection and repair of concrete structures — Test methods — Determination of workability — Part 2: Test for flow of grout or mortar”

EN 14241-1:2013 “Chimneys – Elastomeric seals and elastomeric sealant – Material requirements and test methods- Part1: Seals in flue liners”

EN 14306:2009+A1:2013 “Thermal insulation products for building equipment and industrial installations – Factory made calcium silicate”

EN 14316-1:2004 “Thermal insulation products for buildings – In situ thermal insulation formed from expanded perlite (EP) products – Part 1: Specification for bonded and loose-fill products before installation”

EN 16510-1:2022 “Residential solid fuel burning appliances — Part 1: General requirements and test methods”

EN 16510-2-1:2022 “Residential solid fuel burning appliances – Part 2-1: Roomheaters

EN ISO 6892-1:2019 “Metallic materials — Tensile testing — Part 1: Method of test at room temperature“

EN ISO 9972:2015 “Thermal performance of buildings – Determination of air permeability of buildings – Fan pressurization method“

EN ISO 10211:2017 “Thermal bridges in building construction — Heat flows and surface temperatures — Detailed calculations”

EN ISO 15630-1:2019 “Steel for the reinforcement and prestressing of concrete — Test methods — Part 1: Reinforcing bars, wire rod and wire”

ANNEX A TEST SEQUENCE FOR THE CHIMNEY KIT W3 G

The testing of the chimney kit W3 G shall be carried out with the following test sequence:

- a) Gas tightness according to Clause 2.2.3
- b) Thermal test on operating conditions according to Clause 2.2.2
- c) Gas tightness according to Clause 2.2.3
- d) Relative movement according to EN 13063-1, Clause 5.2.2³
- e) Thermal test under soot fire conditions according to Clause 2.2.2
- f) Gas tightness according to Clause 2.2.3
- g) Relative movement according to EN 13063-1, Clause 5.2.2³ and abrasion resistance of the clay/ceramic flue liner according to EN 1457-2, Clause 16.12
- h) Condensate resistance and water resistance according to Clause 2.2.6
- i) Flow resistance according to Clause 2.2.4
- j) Thermal resistance according to Clause 2.2.5.

³ Noted in the test sequence for the chimney kit with clay/ceramic flue liner equal to the test sequences given in EN 13063-1 and -2, Annex A.1.