

EUROPEAN ASSESSMENT DOCUMENT

EAD 330046-01-0602

January 2016

FASTENING SCREWS FOR METAL MEMBERS AND SHEETING

The reference title and language for this EAD is English. The applicable rules of copyright refer to the document elaborated in and published by EOTA.

This European Assessment Document (EAD) has been developed taking into account up-to-date technical and scientific knowledge at the time of issue and is published in accordance with the relevant provisions of Regulation (EU) No 305/2011 as a basis for the preparation and issuing of European Technical Assessments (ETA).

Contents

1	Scope of the EAD	4
1.1	Description of the construction product	4
1.2	Information on the intended use(s) of the construction product	5
1.2.1	Intended use(s).....	5
1.2.2	Working life/Durability.....	5
2	Essential characteristics and relevant assessment methods and criteria	6
2.1	Essential characteristics of the product	6
2.2	Methods and criteria for assessing the performance of the product in relation to essential characteristics of the product	7
2.2.1	Shear Resistance of the Connection.....	7
2.2.2	Tension Resistance of the Connection	9
2.2.3	Design Resistance in case of combined Tension and Shear Forces (interaction)	12
2.2.4	Check of Deformation Capacity in case of constraining forces due to temperature	12
2.2.5	Durability.....	12
2.2.6	Reaction to fire	12
3	Assessment and verification of constancy of performance	13
3.1	System(s) of assessment and verification of constancy of performance to be applied	13
3.2	Tasks of the manufacturer	13
3.3	Tasks of the notified body	14
4	Reference documents	15
	List of AnnexES	16
	Annex 1 - Example of Connections Made with the Fastening Screws	17
	Annex 2 - Types of Connections and Corresponding Loading Conditions	18
	Annex 3 - Possible failure modes of connections	19
	Annex 4 - Test Set-up for Pull-through and pull-out Tests	20
	Annex 5 - Shear test Set-up	21

1 SCOPE OF THE EAD

1.1 Description of the construction product

The products are fastening screws (self-drilling and self-tapping screws) made of steel. The fastening screws are normally completed with a metallic washer and an EPDM sealing washer. The fastening screws are made of austenitic stainless steel or galvanised or galvanised and painted carbon steel or a bimetal combination with drill bits made of galvanised or galvanised and painted carbon steel. The fastening screws and the corresponding connections are subject to tension and/or shear forces (for types of loading see Annex 2). Typical failure modes of connections made with fastening are shown in Annex 3. The assessment of the load-bearing capacity of the fastening screws and the corresponding connections are part of the ETA.

Samples of fastening screws are given in Figure 1 and examples for corresponding connections are shown in Annex 1.

Figure 01

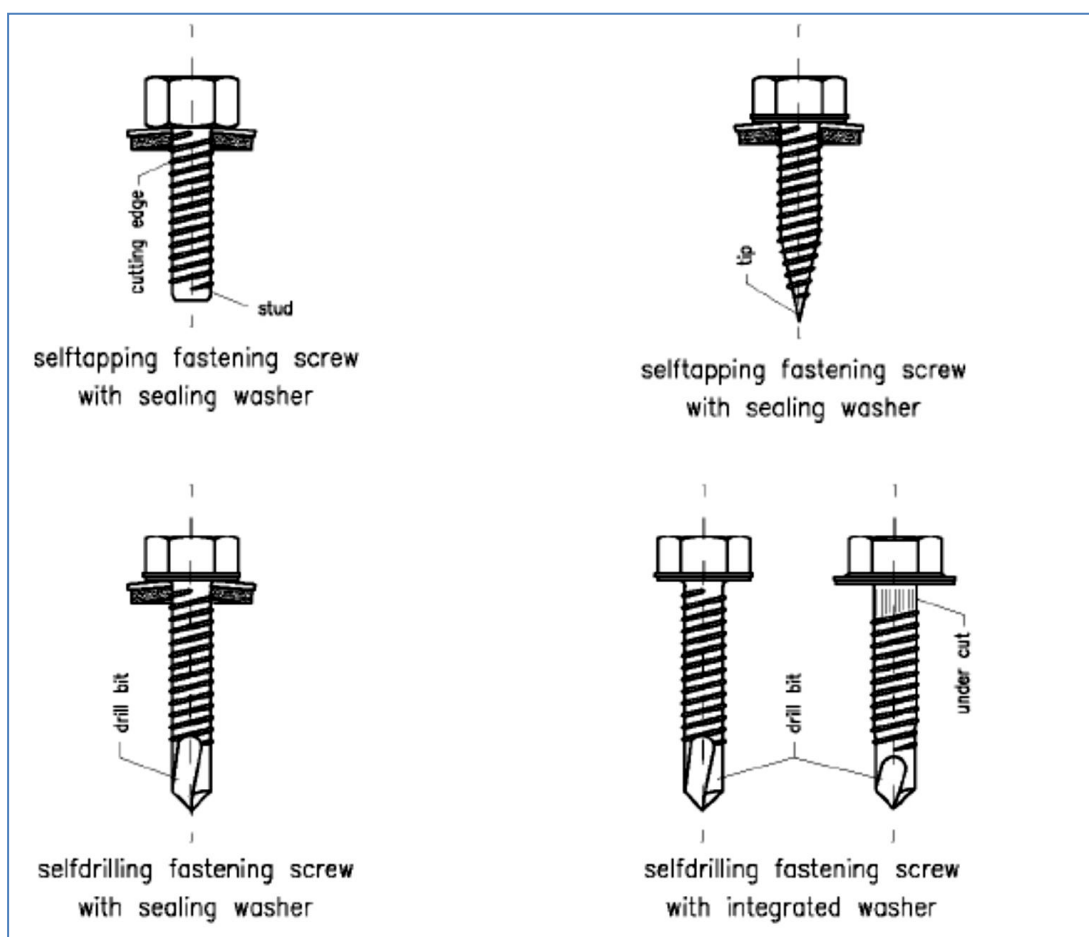

The product is not covered by a harmonised European standard (hEN).

Concerning product packaging, transport, storage, maintenance, replacement and repair it is the responsibility of the manufacturer to undertake the appropriate measures and to advise his clients on the transport, storage, maintenance, replacement and repair of the product as he considers necessary.

It is assumed that the product will be installed according to the manufacturer's instructions or (in absence of such instructions) according to the usual practice of the building professionals.

Relevant manufacturer's stipulations having influence on the performance of the product covered by this European Assessment Document shall be considered for the determination of the performance and detailed in the ETA.

1.2 Information on the intended use(s) of the construction product

1.2.1 Intended use(s)

The fastening screws are intended to be used for fastening metal sheeting to metal or timber supporting substructures. The sheeting can either be used as wall or roof cladding or as load bearing wall and roof element. The fastening screws can also be used for the fastening of any other thin gauge metal members. The intended use comprises fastening screws and connections for indoor and outdoor applications. Furthermore the intended use comprises connections with predominantly static loads (e.g. wind loads, dead loads). The fastening screws for metal members and sheeting are not intended for re-use.

1.2.2 Working life/Durability

The assessment methods included or referred to in this EAD have been written based on the manufacturer's request to take into account a working life of the fastening screws for metal members and sheeting for the intended use of 25 years when installed in the works (provided that the fastening screws for metal members and sheeting are subject to appropriate installation (see 1.1)). These provisions are based upon the current state of the art and the available knowledge and experience.

When assessing the product the intended use as foreseen by the manufacturer shall be taken into account. The real working life may be, in normal use conditions, considerably longer without major degradation affecting the basic requirements for works¹.

The indications given as to the working life of the construction product cannot be interpreted as a guarantee neither given by the product manufacturer or his representative nor by EOTA when drafting this EAD nor by the Technical Assessment Body issuing an ETA based on this EAD, but are regarded only as a means for expressing the expected economically reasonable working life of the product.

¹ The real working life of a product incorporated in a specific works depends on the environmental conditions to which that works is subject, as well as on the particular conditions of the design, execution, use and maintenance of that works. Therefore, it cannot be excluded that in certain cases the real working life of the product may also be shorter than referred to above.

2 ESSENTIAL CHARACTERISTICS AND RELEVANT ASSESSMENT METHODS AND CRITERIA

2.1 Essential characteristics of the product

Table 1 shows how the performance of the fastening screws for metal member and sheeting is assessed in relation to the essential characteristics.

Table 1 Essential characteristics of the product and methods and criteria for assessing the performance of the product in relation to those essential characteristics

No	Essential characteristic	Assessment method	Type of expression of product performance <i>(level, class, description)</i>
Basic Works Requirement 1: Mechanical resistance and stability			
1	Shear Resistance of the Connection	2.2.1	Level(Resistance [kN])
2	Tension Resistance of the Connection	2.2.2	Level(Resistance [kN])
3	Design Resistance in case of combined Tension and Shear Forces (interaction)	2.2.3	Level(pass/fail)
4	Check of Deformation Capacity in case of constraining forces due to temperature	2.2.4	Level(pass/fail)
5	Durability	2.2.5	Level(Acc. to EN ISO 12944, EN 1993-1-3, EN 1993-1-4; EN 1090-1) Level(ISO 4892-2 or -3 (EPDM))
Basic Works Requirement 2: Safety in case of fire			
6	Reaction to fire	2.2.6	Class ((A1) if product meets requirements)

2.2 Methods and criteria for assessing the performance of the product in relation to essential characteristics of the product

2.2.1 Shear Resistance of the Connection

2.2.1.1 Single Layer Tests

At least 10 shear tests with single sheet layers shall be carried out for each relevant combination of sheeting thickness t_s and supporting substructure thickness t_{II} .

The test load shall be increased until shear failure of the fastening screw, misalignment of the fastening screw of 10° or local bearing deformation (hole elongation) of the sheeting or the substructure occurs. The deformation capacity up to maximum load shall be at least 0.5 mm. For metal substructures the maximum load which shall be taken into account to determine the relevant characteristic resistance is the maximum load which corresponds to a deformation capacity of 0.5 mm - 3.0 mm. The rate of deformation should not exceed 1 mm/min.

The load-deformation curves and the respective failure modes as well as the material properties of the sheeting, the substructure and the fastener used for the tests shall be documented in the test report. Furthermore the maximum loads shall be given in the test report. The material properties shall be documented by means of inspection documents 3.1 according to EN 10204. The material properties have to correspond to the material specifications given by the manufacturer.

An example for the test setup is shown in Annex 5. The connection to be tested is the connection "Type a" according to Annex 2.

2.2.1.2 Four Layer Shear Tests

Four layer shear tests are optional tests. If they are carried out the following applies: At least 10 shear tests with 4 sheet layers shall be carried out for each relevant supporting substructure thickness t_{II} . The test load shall be increased until shear failure of the fastening screw, misalignment of the fastening screw of 10° or local bearing deformation (hole elongation) of the sheeting or failure of the substructure. The deformation capacity up to maximum load shall be at least 0.5 mm. The rate of deformation should not exceed 1 mm/min.

For metal supporting substructures the maximum load which shall be taken into account to determine the relevant characteristic resistance is the maximum load which corresponds to a deformation capacity within a range from 0.5mm – 3.0mm. The load-deformation curves and the respective failure modes as well as the material properties of the sheeting, the substructure and the fastening screw used for the tests shall be documented in the test report. Furthermore the maximum loads shall be given in the test report. The material properties shall be documented by means of inspection documents 3.1 according to EN 10204.

The material properties have to correspond to the material specifications given by the manufacturer. An example for the test setup is shown in Annex 5. The connection to be tested is the connection "Type d" according to Annex 2.

The tensile strength of the material of the component with the thickness t (sheeting) should be at the upper limit range according to the relevant product standard (e. g. EN 10346). The maximum possible thickness of the sheeting ($4 \times t_s$) shall be used. This is the maximum thickness for sheeting fastenings where longitudinal and transverse lap joints coincide (side lap and end overlap connection; connection "Type d" according to Annex 2).

2.2.1.3 Determination of Characteristic Shear Resistance

The results of the tests according to 2.2.1.1 and 2.2.1.2 (failure loads or maximum loads) shall be multiplied by the following correction factor α which depends on the failure mode:

- Local bearing of sheeting: $\alpha = (R_{m,min}/R_m) \times (t_{l,min}/t_s) \leq 1.0$

- Local bearing of metal substructure: $\alpha = (R_{m,min}/R_m) \times (t_{II,min}/t_{II}) \leq 1.0$

- Failure of timber substructure: $\alpha = \rho / \rho_{test} \leq 1.0$

- Failure of fastener: $\alpha = F_{shear,min} / F_{shear} \leq 1.0$

With:

$R_{m,min}$ = minimum tensile strength of the relevant metal components t_I or t_{II} according to the relevant product standard

R_m = tensile strength of the relevant metal components t_I or t_{II} used for the tests

ρ = nominal density of the timber

ρ_{test} = density of the timber used for the test (the timber used for the test shall be conditioned in accordance with the relevant standards)

$t_{I,min}$, $t_{II,min}$ = minimum thickness of the relevant components t_I or t_{II} according to the relevant product standard

t_I , t_{II} = thickness of the relevant components t_I or t_{II} used for the tests

$F_{shear,min}$ = minimum shear resistance of the fastener

F_{shear} = shear resistance of the fasteners used for the tests

The corrected test results shall be evaluated statistically (determination of 5% fractile, confidence level 75%). Generally a normal distribution can be assumed.

The determination of the characteristic values of the shear resistance depends on the type of supporting substructure.

For Metal Substructures the following applies:

The corrected and statistically evaluated test results (5% fractile) are the characteristic values $V_{R,k}$ of the shear resistance of the connection.

For Timber Substructures the following applies:

The characteristic values $V_{R,k}$ of the shear resistance of the connections are either the corrected and statistically evaluated test results (5% fractile) or the characteristic values determined according to EN 1995-1-1.

2.2.1.4 Determination of Design Shear Resistance

The determination of the design values of the shear resistance depends on the type of supporting substructure.

For Metal Substructures the following applies:

The design values $V_{R,d}$ of the shear resistance are the characteristic values of the shear resistance according to 2.2.1.3 divided by the recommended partial safety factor $\gamma_M = 1.33$. The recommended partial safety factor γ_M should be used in cases where no value is given in national regulations of the Member State where the fastening screws are used.

For Timber Substructures the following applies:

The design values $V_{R,d}$ of the shear resistance are the characteristic values of the shear resistance according to 2.2.1.3 multiplied by k_{mod} according to EN 1995-1-1, Table 3.1, and divided by the recommended partial safety factor $\gamma_M = 1.33$. If failure of the metal component with the thickness t_I and not failure of the timber substructure is the relevant failure mode then $k_{mod} = 1.0$.

The recommended partial safety factor γ_M should be used in cases where no value is given in national regulations of the Member State where the fastening screws are used.

2.2.2 Tension Resistance of the Connection

2.2.2.1 Static Pull-through Tests

At least 10 pull-through-tests shall be carried out for each relevant sheeting thickness t_i . The test load shall be increased until pull-through of the fastener. The respective failure modes as well as the material properties of the sheeting, the substructure and the fastener used for the tests shall be documented in the test report. Furthermore the failure loads shall be given in the test report. The rate of deformation should not exceed 5 mm/min.

The material properties shall be documented by means of inspection documents 3.1 according to EN 10204. The material properties have to correspond to the material specifications given by the manufacturer.

An example for the test setup is shown in Annex 4. The connection to be tested is the connection "Type a" according to Annex 2.

The tensile strength of the material of the component with the thickness t_i (sheeting) shall be at the lower limit according to the relevant product standard (e. g. EN 10346).

The material properties as well as the thickness of the supporting substructure are optional as long as failure of the substructure is excluded.

2.2.2.2 Cyclic Pull-through Tests

Cyclic pull-through tests are additional optional tests. If they are carried out the following applies:

At least 5 cyclic pull-through test shall be carried out with a constant amplitude load. The minimum load should not be less than 10 % of the maximum load. The loading frequency should be 5 Hz. Each test specimen has to undergo 5,000 load cycles. After passing 5,000 load cycles without any failure of the connection, a static pull-through test given in 2.2.2.1 shall be performed. The pull-out resistance of the fastening screw after the cyclic pull-through test has to be at least 80% of the value evaluated according to the "Static Pull-through test" method given in 2.2.2.1. If one or more specimens fail the cyclic pull-through test or do not reach 80% of the static loading, the tests have to be repeated with a reduced load level.

The correction factor α_{cycl} is determined through

$$\alpha_{cycl} = 1,5 \times (\text{normalised load level with 5000 load changes without damage} / \text{characteristic static pull-through}) \leq 1.0$$

The material properties shall be documented by means of inspection documents 3.1 according to EN 10204. The material properties have to correspond to the material specifications given by the manufacturer.

An example for the test setup is shown in Annex 4. The connection to be tested is the connection "Type a" according to Annex 2.

The tensile strength of the material of the component with the thickness t_i (sheeting) shall be at the lower limit according to the relevant product standard (e. g. EN 10346).

The material properties as well as the thickness of the supporting substructure are optional as long as failure of the substructure is excluded.

2.2.2.3 Pull-out Tests

At least 10 pull-out-tests shall be carried out for each relevant thread engagement or supporting substructure thickness t_i . The test load shall be increased until pull-out or fracture of the fastener. The respective failure modes as well as the material properties of the sheeting, the supporting substructure and the fastener used for the tests shall be documented in the test report. Furthermore the failure loads shall be given in the test report. The material properties shall be documented by means of inspection

documents 3.1 according to EN 10204. The material properties have to correspond to the material specifications given by the manufacturer. The rate of deformation should not exceed 5 mm/min.

An example for the test setup is shown in Annex 4. The connection to be tested is the connection "Type d" according to Annex 2.

The tensile strength of the material of the component with the thickness t_1 (sheeting) is optional. It should be a typical value according to the relevant product standard (e. g. EN 10346). The maximum possible thickness of the sheeting ($4 \times t_1$) shall be used. This is the maximum thickness for sheeting fastenings where longitudinal and transverse lap joints coincide (side lap and end overlap connection; connection "Type d" according to Annex 2).

The material properties of the substructure shall be at the lower limit according to the relevant product standard (e. g. EN 10025-1).

2.2.2.4 Determination of Characteristic Pull-through, Pull-out and Tension Resistance

The test results of the tests according to 2.2.2.1, 2.2.2.2 and 2.2.2.3 (failure loads or maximum loads) shall be multiplied by the following correction factor α which depends on the failure mode:

Tests according to Static or Cyclic pull-through tests:

- Failure of sheeting: $\alpha = (R_{m,min}/R_m) \cdot (t_{1,min}/t_1) \leq 1.0$
- Failure of fastener: $\alpha = F_{tension,min} / F_{tension} \leq 1.0$

Tests according to Pull-out tests:

- Pull out failure (metal substructure): $\alpha = (R_{m,min}/R_m) \cdot (t_{II,min}/t_{II}) \leq 1.0$
- Pull out failure (timber substructure): $\alpha = \rho / \rho_{test} \leq 1.0$
- Failure of fastener: $\alpha = F_{tension,min} / F_{tension} \leq 1.0$

With:

$R_{m,min}$ = minimum tensile strength of the relevant metal components t_1 or t_{II} according to the relevant product standard

R_m = tensile strength of the relevant metal components t_1 or t_{II} used for the tests

ρ = nominal density of the timber

ρ_{test} = density of the timber used for the test (the timber used for the test shall be conditioned in accordance with the relevant standards)

$t_{1,min}$, $t_{II,min}$ = minimum thickness of the relevant components t_1 or t_{II} according to the relevant product standard

t_1 , t_{II} = thickness of the relevant components t_1 or t_{II} used for the tests

$F_{tension,min}$ = minimum tension resistance of the fastener

$F_{tension}$ = tension resistance of the fasteners used for the tests

The corrected test results shall be evaluated statistically (determination of 5% fractile, confidence level 75%). Generally a normal distribution can be assumed.

The corrected and statistically evaluated test results (5% fractile) of the tests according to "Static pull-through tests" are the characteristic values of the static pull-through resistance of the connection.

The statistical evaluation of the results of additional optional cyclic pull-through tests according to “Cyclic pull-through tests” refers to the number of cycles until failure. On the basis of the 5% fractile curve of the number of cycles until failure at a certain load level, which shall be determined from the results of tests on 3 different load levels, the pull-through resistance corresponding to 5000 cycles shall be determined. The result is the characteristic value of the pull-through resistance for repeated wind loads. (Remark: Background information is given in the European Recommendations for the Design and Testing of Connections in Steel Sheeting and Sections, N° 21, May 1983, and the European Recommendations for Sandwich Panels, N° 115, January 2001.)

The characteristic value of the cyclic pull-through resistance for repeated wind loads should be determined as follows:

If no cyclic pull-through tests were carried out, the characteristic value is the characteristic value of the static pull-through resistance multiplied by the following reduction factor, α_{cycl} :

$$\alpha_{cycl} = 2/3 = 0.67$$

If cyclic pull-through tests were carried out, the characteristic value is the characteristic value of the static pull-through resistance multiplied by the following reduction factor: α_{cycl} :

$$\alpha_{cycl} = 1.5 \times (\text{char. cyclic pull-through resistance} / \text{char. static pull-through resistance}) \leq 1.0$$

(Remark: The factor 1.5 takes into account the different safety levels for fatigue design and design for predominantly static loads. α_{cycl} is limited to 1.0.)

The possibly required reduction of the pull-through resistance due to the position of the fastener shall be taken into account according to EN 1993-1-3, section 8.3 (7) and Fig. 8.2 or EN 1999-1-4, Table 8.3.

The determination of the characteristic values of the pull-out resistance depends on the type of substructure.

For Metal Substructures the following applies:

The corrected and statistically evaluated test results (5% fractile) of the tests according to “Pull-out tests” are the characteristic values of the pull-out resistance of the connection.

For Timber Substructures the following applies:

The characteristic values of the pull-out resistance of the connections are either the corrected and statistically evaluated test results (5% fractile) of the tests according to “Pull-out tests” or the characteristic values determined according to EN 1995-1-1.

The characteristic tension resistance $N_{R,k}$ is the minimum value of the characteristic values of either pull-through resistance or relevant pull-out resistance for the corresponding connection.

2.2.2.5 Determination of Design Pull-through, Pull-out and Tension Resistance

The design values of the pull-through resistance are the characteristic values of the pull-through resistance according to 2.2.2.4 divided by the recommended partial safety factor $\gamma_M = 1.33$. The recommended partial safety factor γ_M should be used in cases where no value is given in national regulations of the Member State where the fastening screws are used.

The determination of the design values of the pull-out resistance depends on the type of substructure.

For Metal Substructures the following applies:

The design values of the pull-out resistance are the characteristic values of the pull-out resistance according to 2.2.2.4 divided by the recommended partial safety factor $\gamma_M = 1.33$. The recommended partial safety factor γ_M should be used in cases where no value is given in national regulations of the Member State where the fastening screws are used.

For Timber Substructures the following applies:

The design values of the pull-out resistance are the characteristic values of the pull-out resistance according to 2.2.2.4 multiplied by k_{mod} according to EN 1995-1-1, Table 3.1, and divided by the recommended partial safety factor $\gamma_M = 1.33$. The recommended partial safety factor γ_M should be used in cases where no value is given in national regulations of the Member State where the fastening screws are used.

The design tension resistance $N_{R,d}$ is the minimum value of the design values of either pull-through resistance or relevant pull-out resistance for the corresponding connection.

2.2.3 Design Resistance in case of combined Tension and Shear Forces (interaction)

In case of combined tension and shear forces the linear interaction formula according to EN 1993-1-3, section 8.3 (8) or EN 1999-1-4, section 8.1(7) should be taken into account.

2.2.4 Check of Deformation Capacity in case of constraining forces due to temperature

To check a sufficient deformation capacity of 3 mm in case of constraining forces due to temperature the test results of the shear tests described in 2.2.1.1, 2.2.1.2, 2.2.1.3 and 2.2.1.4 should be used.

2.2.5 Durability

For the corrosion protection of the fastening screws the rules given in EN 1993-1-3, EN 1993-1-4 and EN 1999-1-4 shall be taken into account. Fastening screws which are intended to be used in external environments with $\geq C2$ corrosion according to the standard EN ISO 12944-2 are made of stainless steel.

When the screws are painted and when the paint or coating combination is not given in EN ISO 12944-5, then, testing in accordance with EN ISO 12944-6:1998 shall be carried out. Due to the fact that only the rim of the EPDM sealing washer might be exposed to ageing media, the EPDM sealing washer ensures adequate durability for the intended working life.

If required, the durability of the EPDM sealing washer shall be evaluated with 1000h ageing in accordance with EN ISO 4892-2 or EN ISO 4892-3 followed by the evaluation of water tightening ability after the test.

2.2.6 Reaction to fire

The fastening screws are considered to satisfy the requirements for performance Class A1 of the characteristic reaction to fire, in accordance with the EC Decision 96/603/EC (as amended) without the need for further testing on the basis of its conformity with the specification of the product detailed in that Decision and its intended end use application being covered by that Decision.

Therefore the performance of the product is class A1 according to EN 13501-1.

3 ASSESSMENT AND VERIFICATION OF CONSTANCY OF PERFORMANCE

3.1 System(s) of assessment and verification of constancy of performance to be applied

For the products covered by this EAD the applicable European legal act is: Decision 1998/214/EC, amended by 2001/596/EC

The system to is: **2+**

3.2 Tasks of the manufacturer

The cornerstones of the actions to be undertaken by the manufacturer of the product in the procedure of assessment and verification of constancy of performance are laid down in Table 2.

Table 2 Control plan for the manufacturer; cornerstones

No	Subject/type of control (<i>product, raw/constituent material, component - indicating characteristic concerned</i>)	Test or control method (<i>refer to 2.2 or 3.4</i>)	Criteria, if any	Minimum number of samples	Minimum frequency of control
Factory production control (FPC) [including testing of samples taken at the factory in accordance with a prescribed test plan]					
1	Check of material properties and chemical composition stated in the ETA	Inspection document 3.1. acc. to EN 10204 (to be furnished by the supplier)	Results have to be documented	-	Every production unit
2	Geometry and Dimensions	Check of Geometry, Dimensions and Tolerances	Results have to be documented	10	Every production unit
3	Tension Resistance of Fastening Screws	Check according to test plan	Results have to be documented	10	Every production unit
4	Thread Forming, Drill-drive and Torque Tests	Check according to test plan	Results have to be documented	10	Every production unit
5	Check of initial raw material	Inspection document 3.1 acc. to EN 10204 (to be furnished by the supplier)	Results have to be documented	10	Every production unit
Initial type-testing of the product (ITT)					
6	Geometry and dimension	Check of geometry, dimensions and tolerances	Results have to be documented	10	When starting the production or a new production line

No	Subject/type of control (product, raw/constituent material, component - indicating characteristic concerned)	Test or control method (refer to 2.2 or 3.4)	Criteria, if any	Minimum number of samples	Minimum frequency of control
7	Tension resistance of fastening screws	Check according to test plan	Results have to be documented	10	When starting the production or a new production line
8	Thread forming, drill-drive and torque tests	Check according to test plan	Results have to be documented	10	When starting the production or a new production line

3.3 Tasks of the notified body

The cornerstones of the actions to be undertaken by the notified body in the procedure of assessment and verification of constancy of performance for the fastening screws for metal members and sheeting are laid down in Table 3.

Table 3 Control plan for the notified body; cornerstones

No	Subject/type of control (product, raw/constituent material, component - indicating characteristic concerned)	Minimum frequency of control
Initial inspection of the manufacturing plant and of factory production control (for systems 1+, 1 and 2+ only)		
1	Inspection of factory and factory production control	Before certification
2	Inspection of the testing facilities of the manufacturer	
Continuous surveillance, assessment and evaluation of factory production control (for systems 1+, 1 and 2+ only)		
3	Surveillance and assessment of factory production control	Once a year
4	Surveillance of the testing facilities of the manufacturer	

4 REFERENCE DOCUMENTS

As far as no edition date is given in the list of standards thereafter, the standard in its current version at the time of issuing the European Technical Assessment, is of relevance.

EN 13501-1	Fire classification of construction products and building elements - Part 1: Classification using data from reaction to fire tests
EN 1090-1	Execution of steel structures and aluminium structures
EN 1993-1-3	Eurocode 3: Design of steel structures – Part 1-3: General rules - Supplementary rules for cold-formed members and sheeting
EN 1993-1-4	Eurocode 3: Design of steel structures – Part 1-4: General rules - Supplementary rules for stainless steels
EN 1995-1-1	Eurocode 5: Design of timber structures – Part 1-1:General – Common rules and rules for buildings
EN 1999-1-4	Eurocode 9: Design of aluminium structures – Part 1-4: Cold-formed structural sheeting
EN 10025-1	Hot rolled products of structural steels – Part 1: General technical delivery conditions
EN 10346	Continuously hot-dip zinc coated steel flat products– Technical delivery conditions
EN 10204	Metallic products – Types of inspection documents
EN ISO 12944	Paints and varnishes-Corrosion protection of steel structures by protective paint systems, Part 2 Classification of environments
EN ISO 4892-2	Plastics. Methods of exposure to laboratory light sources. Part 2: Xenon-arc lamps
EN ISO 4892-3	Plastics. Methods of exposure to laboratory light sources. Part 3: Fluorescent UV lamps
EN 1090-1	Execution of steel structures and aluminium structures

LIST OF ANNEXES



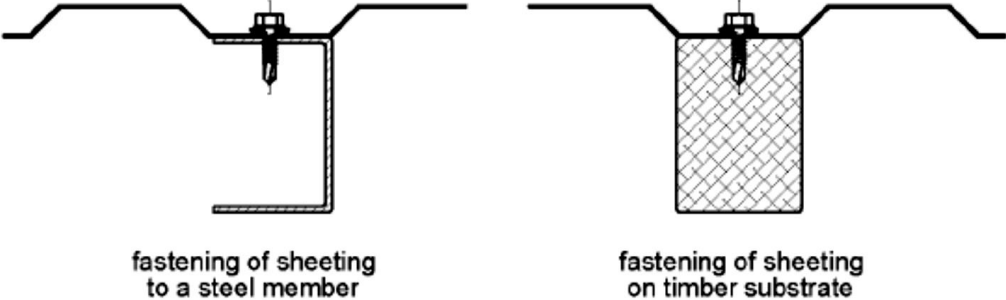

Annex 1	Example of Connections made with the fastening screws	Page. 18
Annex 2	Types of Connections and Corresponding Loading Conditions	Page. 19
Annex 3	Possible Failure Modes of Connections	Page. 20
Annex 4	Test Set-up for Pull-Through and Pull-Out Tests	Page. 21
Annex 5	Shear Test Set-Up	Page. 22

ANNEX 1 - EXAMPLE OF CONNECTIONS MADE WITH THE FASTENING SCREWS



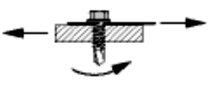

ANNEX 2 - TYPES OF CONNECTIONS AND CORRESPONDING LOADING CONDITIONS

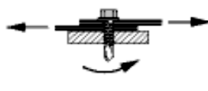
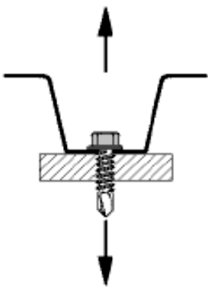
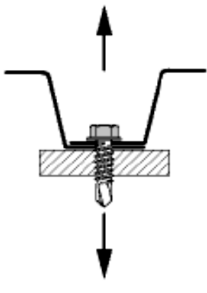
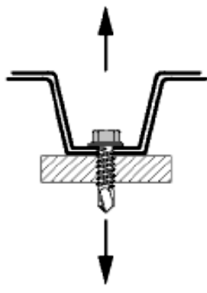
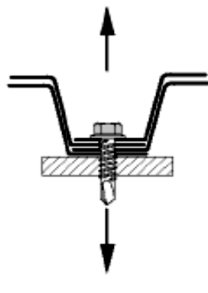
Types of connection and corresponding loading conditions

	Types of connection			
	Type a	Type b	Type c	Type d
				
Type of loading	Single connection	Side lap connection	End overlap connection	Side lap + end overlap connection
Lateral loading due to constraining forces due to temperature, in plane components of wind, dead loads, etc.				
Tension loading due to wind suction				

ANNEX 3 - POSSIBLE FAILURE MODES OF CONNECTIONS

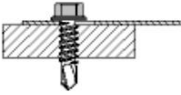
Possible failure modes of connections

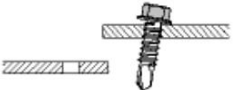
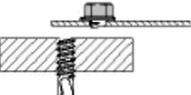
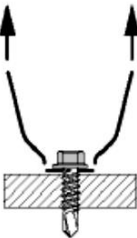
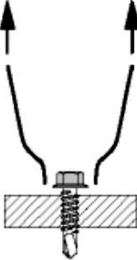
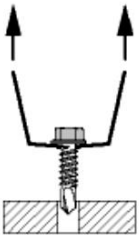
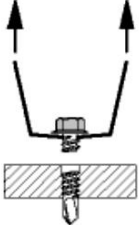
Type of loading	Failing component		
	sheeting	base material	cartridge fired pin
Lateral shear loading	 <p>Slotted hole</p>	 <p>Slotted hole</p>  <p>Rotation of fastener</p>  <p>Pull-out of fastener</p>	 <p>Shear failure</p>
Tensile loading	 <p>Pull-through with punching shear failure</p>  <p>Pull-through</p>	 <p>Pull-out</p>	 <p>Tension failure of fastener</p>

ANNEX 4 - TEST SET-UP FOR PULL-THROUGH AND PULL-OUT TESTS

Pull-through specimen (with or without folded lip)

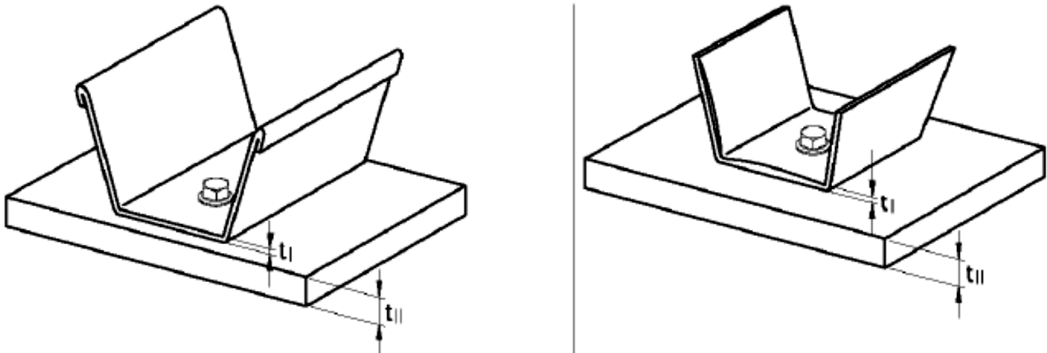

Pull-out test with pull-through specimen

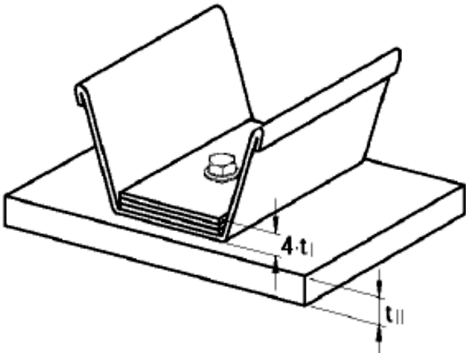

ANNEX 5 - SHEAR TEST SET-UP

