



EUROPEAN ASSESSMENT DOCUMENT

EAD 320008-00-0605

August 2016

SWELLABLE JOINT SEALING TAPE ON THE BASIS OF BENTONITE FOR CONSTRUCTION JOINTS IN WATERTIGHT CONCRETE

The reference title and language for this EAD is English. The applicable rules of copyright refer to the document elaborated in and published by EOTA.

This European Assessment Document (EAD) has been developed taking into account up-to-date technical and scientific knowledge at the time of issue and is published in accordance with the relevant provisions of Regulation No (EU) No 305/2011 as a basis for the preparation and issuing of European Technical Assessments (ETA).

Contents

| | | |
|----------------|---|-----------|
| 1 | Scope of the EAD | 4 |
| 1.1 | Description of the construction product | 4 |
| 1.2 | Information on the intended use(s) of the construction product | 4 |
| 1.2.1 | Intended use(s)..... | 4 |
| 1.2.2 | Working life/Durability..... | 4 |
| 2 | Essential characteristics and relevant assessment methods and criteria | 5 |
| 2.1 | Essential characteristics of the product | 5 |
| 2.2 | Methods and criteria for assessing the performance of the product in relation to essential characteristics of the product | 6 |
| 2.2.1 | Reaction to fire | 6 |
| 2.2.2 | Dimensions..... | 6 |
| 2.2.3 | Watertightness in end use condition | 6 |
| 2.2.4 | Swelling behaviour in different liquids at state of delivery..... | 7 |
| 2.2.5 | Reversibility of swelling process..... | 7 |
| 2.2.6 | Swelling pressure | 8 |
| 3 | Assessment and verification of constancy of performance | 9 |
| 3.1 | System(s) of assessment and verification of constancy of performance to be applied | 9 |
| 3.2 | Tasks of the manufacturer | 9 |
| 3.3 | Tasks of the notified body | 9 |
| 3.4 | Special methods of control and testing used for the assessment and verification of constancy of performance | 10 |
| 3.4.1 | Thickness and width..... | 10 |
| 3.4.2 | TGA | 10 |
| 4 | Reference documents | 11 |
| Annex A | Test Equipment for watertightness in end use conditions | 12 |
| Annex B | Test Equipment for swelling pressure | 13 |

1 SCOPE OF THE EAD

1.1 Description of the construction product

The construction product is a swellable joint sealing tape on the basis of bentonite hereinafter referred as sealing tape.

The water stop consists of the following components:

- Sealing mass on the basis of bentonite
- if necessary, coating, foil, reinforcement material to keep the mass in shape

optional:

- features for fixing the sealing tape during installation (e.g. grid, nails, glue)

The product will be described by the manufacturer taking into account the following characteristics and methods to derive the relevant definitions:

| Number | Product characteristic | Assessment method |
|--------|------------------------|--|
| 1 | Weight per m | weighing |
| 2 | TGA | e.g. DIN 52005 (550 °C) / EN ISO 11358 and 3.4.2 |

The product is not covered by a harmonised European standard (hEN).

Concerning product packaging, transport, storage, maintenance, replacement and repair it is the responsibility of the manufacturer to undertake the appropriate measures and to advise his clients on the transport, storage, maintenance, replacement and repair of the product as he considers necessary.

It is assumed that the product will be installed according to the manufacturer's instructions or (in absence of such instructions) according to the usual practice of the building professionals.

Relevant manufacturer's stipulations having influence on the performance of the product covered by this European Assessment Document shall be considered for the determination of the performance and detailed in the ETA.

1.2 Information on the intended use(s) of the construction product

1.2.1 Intended use(s)

The sealing tape is used to seal construction joints in concrete with high resistance to water (watertight concrete) against the penetration of pressing and un-pressing water (e.g. ground water) and to soil moisture (example see in Annex A).

This EAD covers water stops tested with a maximum test water pressure of 500 kPa (5 bar) and a declared value for the admissible water pressure of 20 m.

Expansion joints are not covered by this EAD.

1.2.2 Working life/Durability

The assessment methods included or referred to in this EAD have been written based on the manufacturer's request to take into account a working life of the sealing tape for the intended use of 50 years when installed in the works (provided that the sealing tape is subject to appropriate installation (see 1.2.1). These provisions are based upon the current state of the art and the available knowledge and experience.

When assessing the product, the intended use as foreseen by the manufacturer shall be taken into account. The real working life may be, in normal use conditions, considerably longer without major degradation affecting the basic requirements for works¹.

The indications given as to the working life of the construction product cannot be interpreted as a guarantee neither given by the product manufacturer or his representative nor by EOTA when drafting this EAD nor by the Technical Assessment Body issuing an ETA based on this EAD, but are regarded only as a means for expressing the expected economically reasonable working life of the product.

2 ESSENTIAL CHARACTERISTICS AND RELEVANT ASSESSMENT METHODS AND CRITERIA

2.1 Essential characteristics of the product

Table 1 shows how the performance of the sealing tape is assessed in relation to the essential characteristics.

Table 1 Essential characteristics of the product and methods and criteria for assessing the performance of the product in relation to those essential characteristics

| No | Essential characteristic | Assessment method | Type of expression of product performance <i>(level, class, description)</i> |
|---|--|-------------------|---|
| Basic Works Requirement 2: Safety in case of fire | | | |
| 1 | Reaction to fire | 2.2.1 | Class |
| Basic Works Requirement 3: Hygiene, health and the environment | | | |
| 2 | Dimensions | 2.2.2 | Level |
| 3 | Watertightness in end use condition | 2.2.3 | Level |
| 4 | Swelling behaviour in different liquids at the state of delivery | 2.2.4 | Description / Level |
| 5 | Reversibility of swelling process | 2.2.5 | Description / Level |
| 6 | Swelling pressure | 2.2.6 | Level |

¹ The real working life of a product incorporated in a specific works depends on the environmental conditions to which that works is subject, as well as on the particular conditions of the design, execution, use and maintenance of that works. Therefore, it cannot be excluded that in certain cases the real working life of the product may also be shorter than referred to above.

2.2 Methods and criteria for assessing the performance of the product in relation to essential characteristics of the product

If the ETA contains performance levels in relation to the essential characteristics dimensions, watertightness in end use condition and swelling behavior at state of delivery, reversibility of swelling process and swelling pressure, these levels are to be expressed as provide for in paragraph 2.2.2, 2.2.3, 2.2.4, 2.2.5 and 2.2.6

2.2.1 Reaction to fire

The sealing tape shall be tested, using the test method(s) relevant for the corresponding reaction to fire class, in order to be classified according to EN 13501-1 and Commission Delegated Regulation (EU) 2016/364.

2.2.2 Dimensions

The length, width and thickness shall be measured.

The dimensions shall be given in the ETA.

2.2.3 Watertightness in end use condition

The water tightness shall be tested in the testing device described in Annex A.

At least two samples of the water stop are cut to length and bent to a square of 680 mm side length. The water stop shall be installed and fixed on the bottom plate according to the applicant's instructions.

The joints can be made as a butt joint or an overlapping joint. The joint shall be made with features and dimensions according to the applicant's instructions.

After curing of the concrete of the bottom plate (at least 14 days) the upper part of the frame can be concreted (maybe with a foil to induce the joint). The setting of the gap between bottom plate and frame (wall) to joint width of testing gap must be done with the help of screws.

Test conditions

Water pressure: The test water pressure shall be defined by the applicant. The maximum test water pressure is 500 kPa (5 bar). The tests shall be performed taking the safety factor of 2,5 into account (e.g. for a declared value for the admissible water pressure of 10 m, the test pressure is 250 kPa (2,5 bar)).

Joint width: Construction joints: Opening from 0 mm to 0,25 mm

Test cycle:

- filled with water (water column 0,28 m) 3 days (without additional pressure)
- increase the test pressure with 20 kPa per day until 100 kPa
- hold 3 days with 100 kPa
- increase the test pressure with 100 kPa per day until the maximum test pressure is reached.
- hold for 2 weeks
- The sample and the testing devices shall be dried for at least 6 weeks (ventilated, heated (joint)) resp. 8 weeks at normal conditions.

The test cycle shall be carried out in total for three times.

The joint between bottom and wall shall be watertight. The scenario of intended use and the admissible water pressure shall be stated in the ETA.

2.2.4 Swelling behaviour in different liquids at state of delivery

The swelling behaviour of the material as well as its reaction to wet-dry cycles over time shall be tested by swelling tests carried out using water as well as other liquids commonly found in concrete construction.

3 test-specimens with a length of 15 cm shall be cut out of a section of joint sealing strip of at least 1 m length.

Not inherently stable materials – primarily bentonites – shall be wrapped in a water-permeable, flexible and easily stretchable cover made of polyamide blended with spandex 40 den/44 dtex.

The test specimens shall be measured and weighed before immersing them into the test liquids in a closed container. The following test liquids shall be used:

Test liquid 1: deionised water

Test liquid 2: alkaline solution: 1 g NaOH, 4 g KOH, 0,5 g Ca (OH)₂ to one liter of distilled water (see ETAG 004).

Test liquid 3: liquid with pH-value of 4.5: SO₄²⁻ content > 4000 mg/l, pH-value adjusted by using SO₄²⁻, sulphate content adjusted by using Na₂SO₄ in aqueous solution

The tests shall be carried out 23±2°C/50±2 % rel. humidity.

The material's behaviour under constant exposure shall be observed. During the first week variations in mass shall be recorded on a daily basis. For inherently stable materials, changes in the dimensions shall also be recorded. For the first swelling process a time lag should be accepted.

The variations in mass shall be determined at material-specific intervals with an accuracy of 0,1 g until the mass remains constant.

The test period depends on the swelling capacity. As soon as the variation in mass of all three test specimens measured on a daily basis is $\Delta m_{48} \leq 2\%$ over 48 h, the immersion test can be terminated.

The test report shall feature the maximum mass variations recorded as well as a diagram showing the variations over time.

Based on experience the function of swelling and sealing is given if the time of change of mass is limited.² Otherwise the function of swelling cannot be verified on the basis of this EAD.

The time until the change of mass ends shall be given in the ETA.

2.2.5 Reversibility of swelling process

To prove that the swelling process can be repeated after drying, the test procedure according to 2.2.4 shall be repeated twice.

After having reached a plateau under normal climatic conditions (23/50-2), the test specimens are dried until their mass remains once more constant.

Then they are immersed in the liquid again. In total, three of these cycles (immersion into the liquid and drying under normal climatic conditions) shall be carried out.

The test report shall feature the maximum mass variations recorded as well as a diagram showing the variations over time.

The time of change of mass shall not be longer than for the first swelling process (see 2.2.4).

Based on experience the reversibility of swelling process is given if the swelling process starts without time lag. Otherwise the reversibility of swelling process cannot be verified on the basis of this EAD.

² Usually it can be taken up to 3 month.

2.2.6 Swelling pressure

If the increase in volume of the joint sealant caused by its absorbing water is constrained, the swelling creates a pressure. The level of this swelling pressure depends on the geometry, the type of joint sealant used and the degree of constraint.

The water tightness shall be tested in the testing device described in Annex B.

To measure the swelling pressure, a two-part concrete test specimens made of watertight concrete, dimensions: (20 x 20 x 20) cm³, shall be manufactured.

Concrete: C30/37, CEM I 32,5 R, w/z = 0,55,
aggregates on the basis of quartz, maximum particle size 16 mm

Post-treatment: 7 d wet

The lower part of the test specimen shall be stored in water at ambient climate immediately after striking until the test is carried out, however, for not less than 28 days.

A 10 cm-long section of the material to be tested shall be fastened in the middle of the lower part of the test specimen in accordance with the manufacturer's instructions, before the upper concrete part is cast.

Two days after finishing the test specimen (casting of the upper half), the construction joint shall be widened to 0,25 mm ensuring that the test liquid can reach the sealing tape inserted. Steel strips shall be used to ensure that the joint opening is maintained at 0,25 mm for the entire duration of the test. Afterwards, the test specimens shall be incorporated immediately in a highly deformation-resistant, rigid frame connected to a force measuring device. A preload shall be added (see Annex B). The preload shall not exceed 2 kN. The aim of this is to eliminate backlash and ensure controlled starting conditions. The liquid level shall be high enough to make sure that the lower part of the test specimen as well as the construction joint is immersed in the liquid. The test liquid shall be demineralised water.

The sealing tape and the design of the test specimens are sufficient to constrain the swelling and ensure that the swelling pressure can be measured reliably. The tests shall be carried out with three test specimens over a duration of no less than one month until the swelling pressure levels out. Once the maximum pressure level has been reached, the test specimens shall be opened and the sealing tape inspected visually. If parts of the material leaked out into the joint, this shall be documented. In addition to the swelling pressures recorded, the test report shall detail all incidents and particularities (e.g. when material leaked out into the joint.)

Based on experience the function of sealing is durable if the swelling process pressure is > 0,5 N/mm². Otherwise the function of sealing cannot be verified on the basis of this EAD.

The swelling pressure shall be stated in the ETA.

3 ASSESSMENT AND VERIFICATION OF CONSTANCY OF PERFORMANCE

3.1 System(s) of assessment and verification of constancy of performance to be applied

For the products covered by this EAD the applicable European legal act is: Decision 1999/90/EC

The system is: **3**

In addition, with regard to e.g. reaction to fire for products covered by this EAD the applicable European legal act is: Decision 1999/90/EC

The systems are: **1, 3 and 4**

3.2 Tasks of the manufacturer

The cornerstones of the actions to be undertaken by the manufacturer of the product in the procedure of assessment and verification of constancy of performance are laid down in Table 2.

Table 2 Control plan for the manufacturer; cornerstones

| No | Subject/type of control (product, raw/constituent material, component - indicating characteristic concerned) | Test or control method (refer to 2.2 or 3.4) | Criteria, if any | Minimum number of samples | Minimum frequency of control |
|--|--|---|------------------|---------------------------|------------------------------|
| Factory production control (FPC) [including testing of samples taken at the factory in accordance with a prescribed test plan] | | | | | |
| 1 | Geometry | 3.4.1 | ± 10 % | 1 | Each batch resp. each 1000 m |
| 2 | Mass per m | weighing | ± 3 % | 1 | Each batch resp. each 1000 m |
| 3 | Ash Content / TGA | e.g. DIN 52005 (550 °C) / EN ISO 11358 and 3.4.2 | ± 10 % | 1 | Once a year |

3.3 Tasks of the notified body

The cornerstones of the actions to be undertaken by the notified body of the product in the procedure of assessment and verification of constancy of performance are laid down in Table 3.

Table 3 Control plan for the notified body; cornerstones

| No | Subject/type of control <i>(product, raw/constituent material, component - indicating characteristic concerned)</i> | Test or control method <i>(refer to 2.2 or 3.4)</i> | Criteria, if any | Minimum number of samples | Minimum frequency of control |
|---|--|--|------------------|---------------------------|------------------------------|
| Initial inspection of the manufacturing plant and of factory production control <i>(for systems 1+, 1 and 2+ only)</i> | | | | | |
| 1 | Reaction to fire | 2.2.1 | | 1 | Once a year |
| Continuous surveillance, assessment and evaluation of factory production control <i>(for systems 1+, 1 and 2+ only)</i> | | | | | |
| 1 | Reaction to fire | 2.2.1 | | 1 | Once a year |

3.4 Special methods of control and testing used for the assessment and verification of constancy of performance

3.4.1 Thickness and width

Thickness and width shall be measured at 10 measuring points on at least 1 m section with a minimum precision of $\pm 0,05$ mm. The mean value and the standard deviation have to be determined.

3.4.2 TGA

Range of temperature: 0 °C – 1000 °C

Heating rate: 20 K/min

Flushing gas: inert;

Rate of flushing: 100 ml/min, then assessment of ash content

The individual steps of weight loss (determination by tangent method) are recorded in mass [%] with the respective temperature. Thermograms shall be attached to the test report.

4 REFERENCE DOCUMENTS

As far as no edition date is given in the list of standards thereafter, the standard in its current version at the time of issuing the European Technical Assessment is of relevance.

| | |
|--------------|--|
| EN 13501-1 | Fire classification of construction products and building elements - Part 1: Classification using data from reaction to fire tests |
| EN ISO 2811 | Paints and varnishes - Determination of density |
| EN 206-1 | Concrete - Part 1: Specification, performance, production and conformity |
| EN ISO 11358 | Plastics - Thermogravimetry (TG) of polymers - General principles |

ANNEX A TEST EQUIPMENT FOR WATERTIGHTNESS IN END USE CONDITIONS

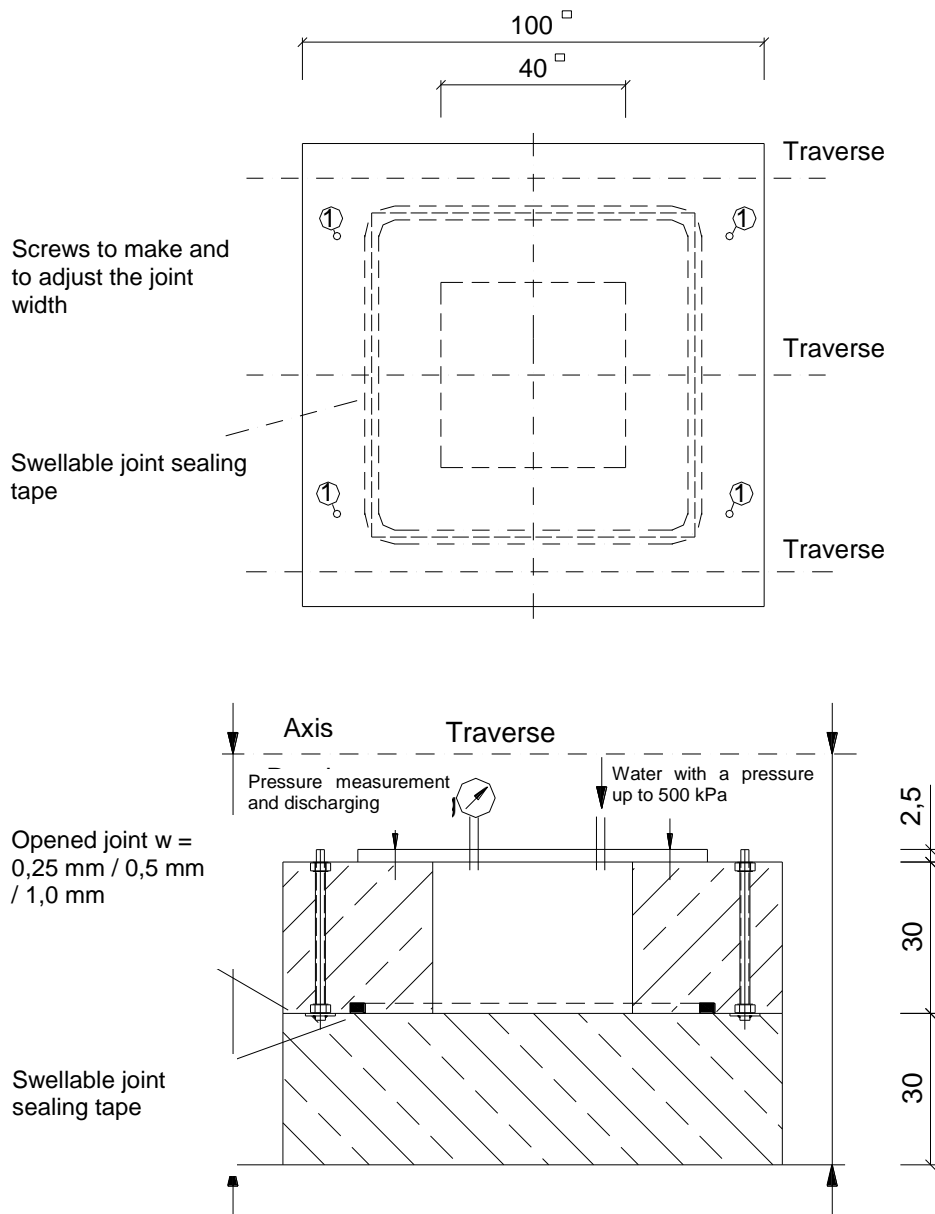

The two-part concrete test specimens shall be made of watertight concrete, e.g. the following composition:

C30/37, CEM I 32,5 R, $w/z = 0,55$,
aggregates on the basis of quartz, maximum particle size 16 mm

ANNEX B TEST EQUIPMENT FOR SWELLING PRESSURE

