



[www.eota.eu](http://www.eota.eu)

**EAD 220034-00-0607**

April 2017

European Assessment Document for

# Roof tile coupling system



The reference title and language for this EAD is English. The applicable rules of copyright refer to the document elaborated in and published by EOTA.

This European Assessment Document (EAD) has been developed taking into account up-to-date technical and scientific knowledge at the time of issue and is published in accordance with the relevant provisions of Regulation (EU) 305/2011 as a basis for the preparation and issuing of European Technical Assessments (ETA).

## Contents

<b>1</b>	<b>Scope of the EAD</b> .....	<b>4</b>
1.1	Description of the construction product	4
1.2	Information on the intended use(s) of the construction product	5
1.2.1	Intended use(s).....	5
1.2.2	Working life/Durability.....	5
<b>2</b>	<b>Essential characteristics and relevant assessment methods and criteria</b> .....	<b>7</b>
2.1	Essential characteristics of the product	7
2.2	Methods and criteria for assessing the performance of the product in relation to essential characteristics of the product	7
2.2.1	Tensile load .....	7
2.2.2	Withstand vibrations capability .....	9
<b>3</b>	<b>Assessment and verification of constancy of performance</b> .....	<b>12</b>
3.1	System(s) of assessment and verification of constancy of performance to be applied	12
3.2	Tasks of the manufacturer	12
<b>4</b>	<b>Reference documents</b> .....	<b>13</b>

## 1 SCOPE OF THE EAD

### 1.1 Description of the construction product

The product is a roof tile coupling system, obtained from the millwork of a rounded steel EN 1.4301 or steel EN 1.4597 or, in case of severe environmental conditions, in steel EN 1.4401 (steel classification according to EN 10088-2:2014<sup>1</sup>). The roof tile coupling system has a rectangular section with minimum sizes of 3,4 x 2,2 mm. The system includes four kinds of hooks which are clasped to the upper or lower tiles of the entire roofing, depending on their function. They are:

- tile-to-tile hook;
- underlayment pitch-to-bottom bent tile hook;
- underlayment pitch-to-upper bent tile hook;
- tile-to-grid hook.

This EAD covers possible different configurations of the underlayment pitch-to-tile hooks which allow clasping of the upper and/or lower tiles to different roof covering supporting systems, i.e., with or without supporting battens and considering possible different supporting battens types (i.e., wood or steel supporting battens).

The tile-to-tile hook (Figure 1.1.1), which is designed to guarantee the anchoring of the roof covering, is placed between every tile. The hook is provided with a clip system which keeps its initial position stable over time, preventing its lateral slippage.



**Figure 1.1.1 Tile-to-tile hook.**

The underlayment pitch-to-bottom bent tile hook (Figure 1.1.2) and the underlayment pitch-to-upper bent tile hook (Figure 1.1.3), whose function is to fasten the roof covering to the underlayment, are mechanically fixed to the building with specific screws, with intervals that may vary depending both on the slope of the roof and on environmental conditions.

The tile-to-grid hook (Figure 1.1.4) fastens the bird stopping grid to the eaves tile.

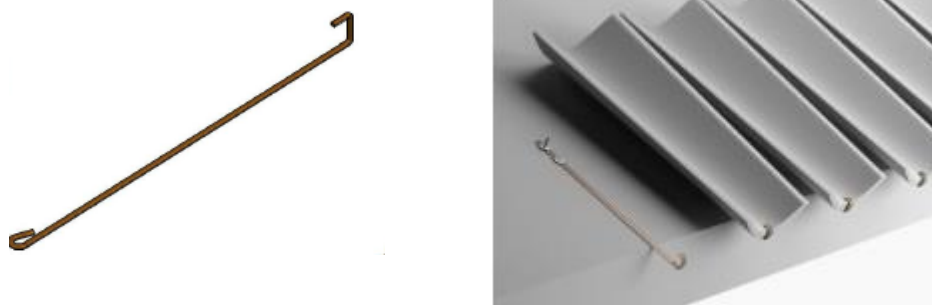

**Figure 1.1.2 Underlayment pitch-to-bottom bent tile hook for roof covering system without supporting battens**

<sup>1</sup> All undated references to standards or to EADs in this EAD are to be understood as references to the dated versions listed in chapter 4.

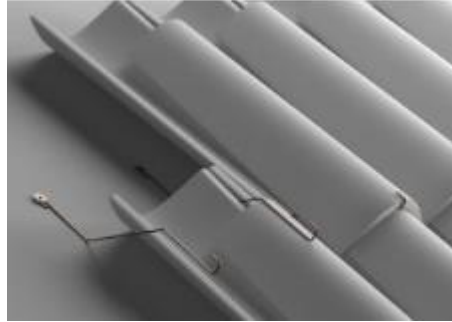

**Figure 1.1.3 Underlayment pitch-to-upper bent tile hook for roof covering system without supporting battens.**



**Figure 1.1.4 Tile-to-grid hook.**

The product is not covered by a harmonised European standard (hEN).

Concerning product packaging, transport, storage, maintenance, replacement and repair it is the responsibility of the manufacturer to undertake the appropriate measures and to advise his clients on the transport, storage, maintenance, replacement and repair of the product as he considers necessary.

It is assumed that the product will be installed according to the manufacturer's instructions or (in absence of such instructions) according to the usual practice of the building professionals.

Relevant manufacturer's stipulations having influence on the performance of the product covered by this European Assessment Document shall be considered for the determination of the performance and detailed in the ETA.

## **1.2 Information on the intended use(s) of the construction product**

### **1.2.1 Intended use(s)**

The roof tile coupling system is intended to fasten roof tiles, in order to prevent tiles slipping due to vibrations (e.g., traffic and/or low scale earthquake actions).

### **1.2.2 Working life/Durability**

The assessment methods included or referred to in this EAD have been written based on the manufacturer's request to take into account a working life of the roof tile coupling system for the intended use of 30 years when installed in the works (provided that the roof tile coupling system is subject to appropriate installation (see 1.1)). These provisions are based upon the current state of the art and the available knowledge and experience.

When assessing the product, the intended use as foreseen by the manufacturer shall be taken into account. The real working life may be, in normal use conditions, considerably longer without major degradation affecting the basic requirements for works<sup>2</sup>.

The indications given as to the working life of the construction product cannot be interpreted as a guarantee neither given by the product manufacturer or his representative nor by EOTA when drafting this EAD nor by the Technical Assessment Body issuing an ETA based on this EAD, but are regarded only as a means for expressing the expected economically reasonable working life of the product.

---

<sup>2</sup> The real working life of a product incorporated in a specific works depends on the environmental conditions to which that works is subject, as well as on the particular conditions of the design, execution, use and maintenance of that works. Therefore, it cannot be excluded that in certain cases the real working life of the product may also be shorter than referred to above.

## 2 ESSENTIAL CHARACTERISTICS AND RELEVANT ASSESSMENT METHODS AND CRITERIA

### 2.1 Essential characteristics of the product

Table 2.1.1 shows how the performance of the roof tile coupling system is assessed in relation to the essential characteristics.

**Table 2.1.1 Essential characteristics of the product and methods and criteria for assessing the performance of the product in relation to those essential characteristics**

No	Essential characteristic	Assessment method	Type of expression of product performance
<b>Basic Works Requirement 4: Safety and accessibility in use</b>			
1	Tensile load	2.2.1	Level $F_y$ [kN] $F_u$ [kN]
2	Withstand vibration capability	2.2.2	Description, Level Overlap length [mm] Limit displacement ( $\Delta_{fallout}$ [mm])

### 2.2 Methods and criteria for assessing the performance of the product in relation to essential characteristics of the product

This chapter is intended to provide instructions for TABs. Therefore, the use of wordings such as “shall be stated in the ETA” or “it has to be given in the ETA” shall be understood only as such instructions for TABs on how results of assessments shall be presented in the ETA. Such wordings do not impose any obligations for the manufacturer and the TAB shall not carry out the assessment of the performance in relation to a given essential characteristic when the manufacturer does not wish to declare this performance in the Declaration of Performance.

#### 2.2.1 Tensile load

##### Purpose of the assessment

The aim of the tests is to verify the tensile load performance of the roof tile coupling system by simulating the specific different in situ conditions for each hook.

##### Assessment method

All the tensile load tests shall be done at room temperature according to EN ISO 6892-1, §5 and applying testing rates according to EN ISO 6892-1, §10.3.2 (Method A1).

A specific device to fix the test pieces (method of gripping) shall be used to simulate hooks stresses as in situ conditions.

The testing apparatus always consists in: a main body, fixed to the basement by bolted connections, to host the hook stem; a standing part, fixed to the main body or to the basement by means of bolted connections, to host one end of the hook; a sliding portion, simply supported by the standing parts, to host the second end of the hook. The two hook ends shall be fixed to the standing and to the sliding part, respectively, by screws or dowels inserted in the hook eye. Depending on the hook length and geometry, additional standing parts allow different relative distances and heights of the two hook ends.

Sliding is guaranteed by PTFE layers.

Loads shall be applied to the sliding part of the testing apparatus by means of strain gauge and/or piezoelectric load cells. Figure 2.2.1.1 shows a schematic view of the testing machine arrangement.

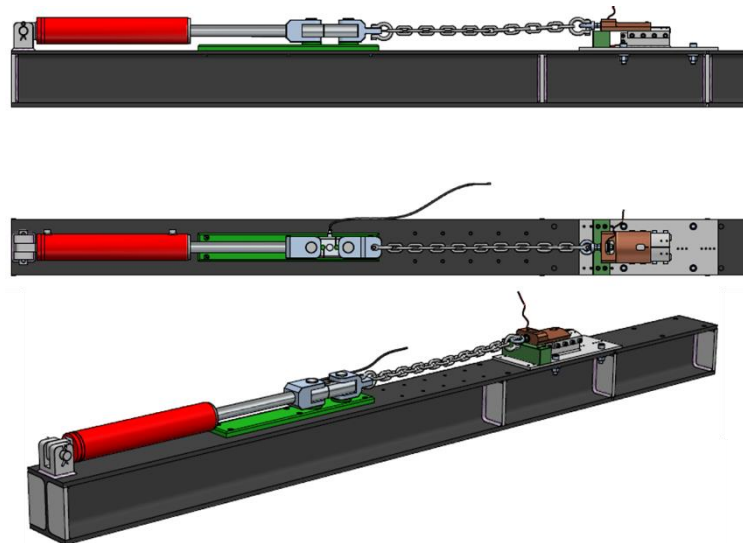

**Figure 2.2.1.1 Example of the testing machine arrangement.**

Details of the testing apparatus for the tile-to-tile hook are reported in Figure 2.2.1.2. For each hook type, a specific configuration shall be used. In Figure 2.2.1.3, the configurations for the four types of hooks (described in Figure 1.1.1 to Figure 1.1.4) are reported.

The test shall be conducted on 5 specimens for each type of hook.

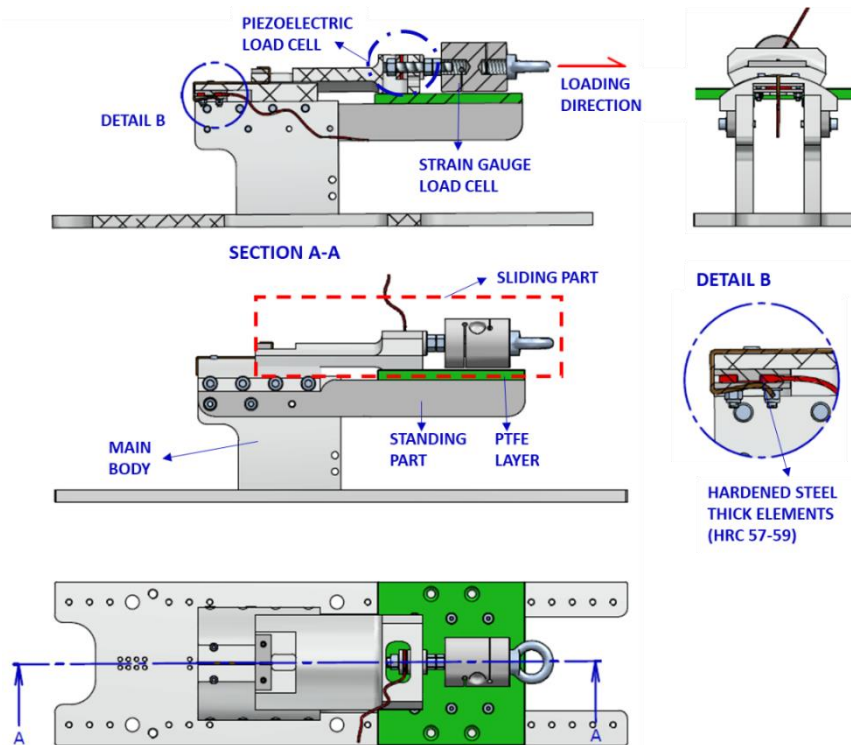

**Figure 2.2.1.2 Example of the experimental set-up for the tile-to-tile hook.**



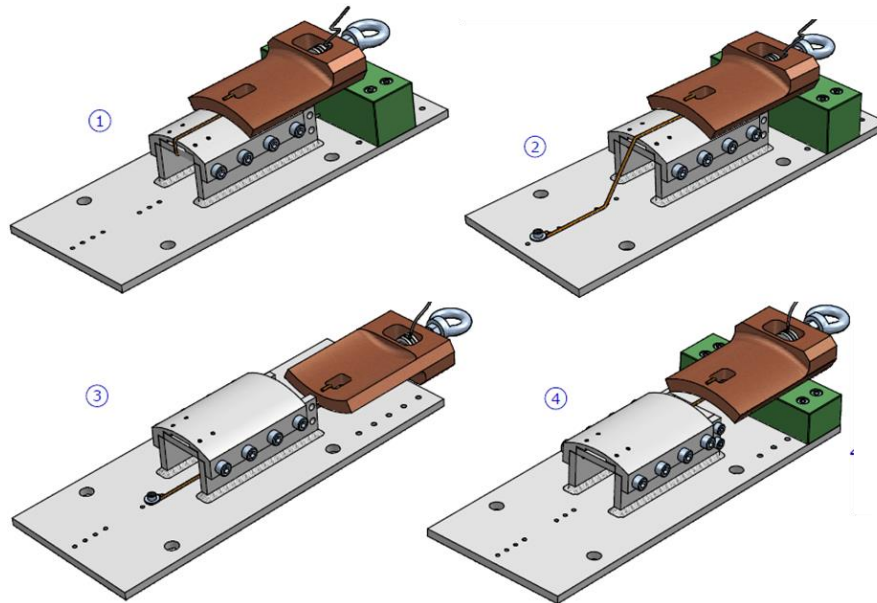

**Figure 2.2.1.3 Experimental set-up adaptable to each type of hook. 1) tile-to-tile hook; 2) underlayment pitch-to-upper bent tile hook; 3) underlayment pitch-to-bottom bent tile hook; 4) tile-to-grid hook.**

### Expression of results

Parameters to be recorded during the test are at least:

- instantaneous values of the load-displacement;
- yield load;
- maximum load;
- specimen photos taken during and after the test.

For each hook configuration, the following parameters shall be stated in the ETA:

- mean (arithmetic average), minimum and maximum value of the maximum tensile load ( $F_u$  [kN]), i.e., tensile load at fracture of the tested specimens by each tested hook type;
- mean (arithmetic average), minimum and maximum value of the yield load ( $F_y$  [kN]) of the tested specimens by each tested hook type.

## **2.2.2 Withstand vibrations capability**

### Purpose of the assessment

The aim of the test is to verify if the roof tile coupling system, when assembled with tiles on site, can maintain tiles in the right position under vibrations due to simulated actions of traffic and / or low scale earthquake actions.

### Assessment method

The experimental setup shown below (Figure 2.2.2.1) shall be subjected to a base time-history utilizing monotonically increasing-amplitude sinusoidal drift cycles to determine drift limits which correspond to relative movements between tiles or tiles fall.

The test frame shall have a low fundamental period (frequency higher than 30 Hz), outside of the roof tiles range frequencies, in order to avoid resonance problems. The sizes of the test frame shall be designed such to permit the positioning of a minimum number of 4 tiles in both directions.

The test procedure is reported in the following.

The test consists in a concatenated series of “ramp-up” intervals and “constant amplitude” intervals (“crescendo test”). As depicted in Figure 2.2.2.2, displacement steps between constant amplitude intervals shall be 5 mm. Ramp-up intervals and constant amplitude intervals shall consist of four sinusoidal cycles each. The maximum amplitude to reach shall be 50 mm. Each crescendo test shall be performed at different frequencies, namely 0,5 Hz, 1,0 Hz, 2 Hz and 3,0 Hz.

Each crescendo test at the same frequency shall be run continuously until completion. Each crescendo test shall proceed until the first of the following conditions exists: *i)* tile fall-out from the support; *ii)* the dynamic displacement of  $\pm 50$  mm is reached.

The test shall be conducted in the main direction X, as indicated in Figure 2.2.2.1, and may be optionally performed in the perpendicular direction Y. No actions shall be applied in the Z-direction.

The tests shall be performed by shaking table facilities (shake table testing) which allow to reproduce the conditions indicated above.

Test set-up includes:

- preparation of roof specimen according to the manufacturer’s product installation instructions;
- two different positions of the testing specimen, i.e., two different slopes of the roof arrangement equal to 35% and 45%, for considering typical applications of the product in real cases.

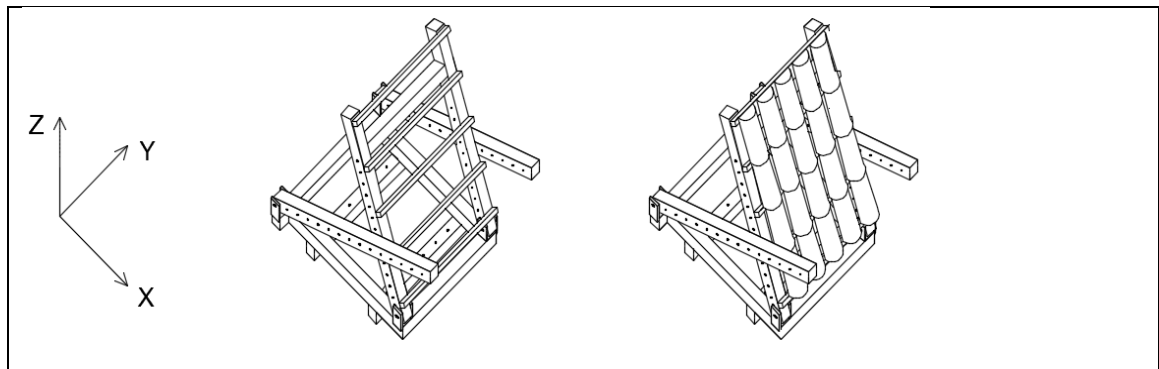

Figure 2.2.2.1 Example of the experimental set-up.

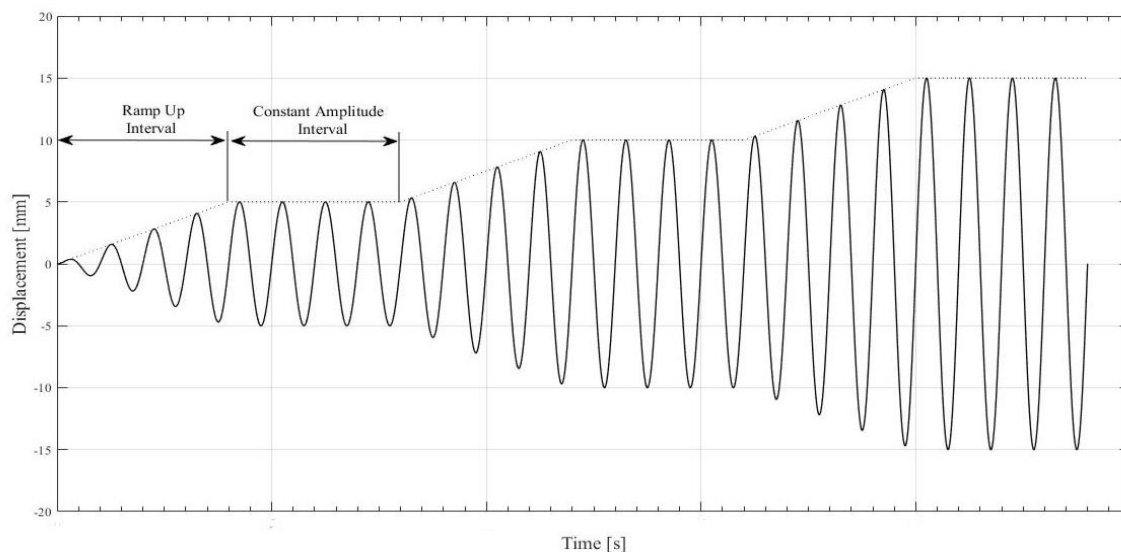

Figure 2.2.2.2 Schematic of displacement time-history for a fixed frequency.

Expression of results

The considered test set-up shall be described in the ETA, in terms of: hook type and dimensions; testing apparatus configuration (e.g., slope of the roof arrangement).

Parameters to be recorded during the test are at least:

- limit displacement beyond which the first tile falls ( $\Delta_{\text{fallout}}$  [mm]) at the correspondent frequency;
- displacement beyond which there is the detachment of hooks from the crossbar;
- tile-to-tile overlap length measured at the end of the test at each frequency;
- specimen photos taken during and after the test.

The following parameters shall be stated in the ETA, with direct reference to each adopted test set-up configuration:

- minimum recorded overlap length measured at the end of the test at each frequency.
- limit displacement beyond which the first tile falls ( $\Delta_{\text{fallout}}$  [mm]) at the correspondent frequency.

### 3 ASSESSMENT AND VERIFICATION OF CONSTANCY OF PERFORMANCE

#### 3.1 System(s) of assessment and verification of constancy of performance to be applied

For the products covered by this EAD the applicable European legal act is: Commission Decision 1998/436/EC as amended by Commission Decision 2001/596/EC.

The system is: 3

#### 3.2 Tasks of the manufacturer

The cornerstones of the actions to be undertaken by the manufacturer of the product in the procedure of assessment and verification of constancy of performance are laid down in Table 3.2.1.

**Table 3.2.1 Control plan for the manufacturer; cornerstones**

No	Subject/type of control	Test or control method	Criteria, if any	Minimum number of samples	Minimum frequency of control
<b>Factory production control (FPC)</b> [including testing of samples taken at the factory in accordance with a prescribed test plan]					
1	<i>Steel wire</i> /Tensile load	Clause 2.2.1	As defined in the control plan	6	Each batch
2	<i>Finished product</i> /Geometry	EN 10218-2	As defined in the control plan	6	Each batch

## 4 REFERENCE DOCUMENTS

EN 10088-2:2014	Stainless steels - Part 2: Technical delivery conditions for sheet/plate and strip of corrosion resisting steels for general purposes
EN 10218-2:2012	Steel wire and wire products. General. Wire dimensions and tolerances
EN ISO 6892-1:2019	Metallic materials - Tensile testing - Part 1: Method of test at room temperature