

EUROPEAN ASSESSMENT DOCUMENT

EAD 090058-00-0404

November 2016

VENTILATED EXTERNAL WALL CLADDING KIT COMPRISING A METALLIC HONEYCOMB PANEL AND ITS ASSOCIATED FIXINGS

The reference title and language for this EAD is English. The applicable rules of copyright refer to the document elaborated in and published by EOTA.

This European Assessment Document (EAD) has been developed taking into account up-to-date technical and scientific knowledge at the time of issue and is published in accordance with the relevant provisions of Regulation (EU) No 305/2011 as a basis for the preparation and issuing of European Technical Assessments (ETA).

Contents

1	Scope of the EAD	5
1.1	Description of the construction product	5
1.2	Information on the intended use of the construction product	6
1.2.1	Intended use.....	6
1.2.2	Working life/Durability.....	6
1.3	Specific terms used in this EAD	6
1.3.1	Cladding kit.....	6
1.3.2	Substrate	6
1.3.3	Non-continuous subframe	7
1.3.4	Cladding element	7
1.3.5	Cladding fixing	7
1.3.6	Coating	7
1.3.7	Air space.....	7
1.3.8	Ventilated air space	7
1.3.9	Open joints	7
2	Essential characteristics and relevant assessment methods and criteria	8
2.1	Essential characteristics of the product	8
2.2	Methods and criteria for assessing the performance of the product in relation to essential characteristics of the product.....	9
2.2.1	Reaction to fire	9
2.2.2	Watertightness of joints (protection against driving rain)	9
2.2.3	Drainability.....	10
2.2.4	Wind load resistance	10
2.2.5	Compression strength of cladding element.....	11
2.2.6	Tensile strength of cladding element	11
2.2.7	Peeling strength of cladding element	11
2.2.8	Shear strength and force-deflection coefficient of cladding element	11
2.2.9	Mechanical resistance of the combination of fixing devices	11
2.2.10	Shear resistance of fixing from panel.....	11
2.2.11	Combined tension and shear resistance of fixing from panel	11
2.2.12	Resistance to horizontal point loads.....	11
2.2.13	Impact resistance	12
2.2.14	Pulsating load	12
2.2.15	Corrosion of cladding element.....	12
2.2.16	Corrosion of metal components (except cladding element)	12
2.2.17	Resistance to ageing by UV radiation of cladding element.....	13
2.2.18	Resistance to thermal shock	13
2.2.19	Durability of the adherence of the honeycomb to the sheets.....	13
3	Assessment and verification of constancy of performance	13
3.1	System(s) of assessment and verification of constancy of performance to be applied	13
3.2	Tasks of the manufacturer	14
3.3	Tasks of the notified body.....	15
4	Reference documents	16
	Annex A – Description of the components	18
	Annex B – Additional criteria for watertightness tests	19
	Annex C – Wind suction and pressure loads tests	21

Annex D – Compression strength of the cladding element	24
Annex E – Tensile strength of the cladding element	26
Annex F – Peeling strength of the cladding element	28
Annex G – Shear strength and force-deflection coefficient of the cladding element	30
Annex H – Mechanical resistance of the combination of fixing devices	33
Annex I – Shear resistance of fixing from cladding element	35
Annex J – Combined tension and shear resistance of fixing from cladding element	37
Annex K – Impact resistance test	39
Annex L – Pulsating load	42
Annex M – Resistance to thermal shock	43
Annex N – Determination of the durability of the adherence of the honeycomb to the metallic sheets by change in shear strength	47
Annex O – General test results statistical interpretation	50

1 SCOPE OF THE EAD

1.1 Description of the construction product

This EAD is applicable to the kits¹ for ventilated external wall claddings consisting of metallic honeycomb panels as external cladding element, a non-continuous metallic subframe and its associated fastening devices.

The kit for external wall claddings consists of the following components from the substrate to the cladding element:

- Metallic brackets (one of them fixed or anchored to the substrate and the other one/s mobile) and its fasteners which allow positioning of the cladding element in 2 or 3 axes.
- Metallic pieces or hangs fastened to the mobile brackets, which are used to hang the cladding element.
- Metallic pieces or hooks, hanging from the metallic hangs and fastened to the cladding element with rivets or other mechanical fixings.
- Ancillary materials that restrict vertical movement of the cladding element can be included.
- Cladding element, sandwich panel with two exterior metallic skins with coating and an internal metallic honeycomb core which is bonded with an organic adhesive to the skins.

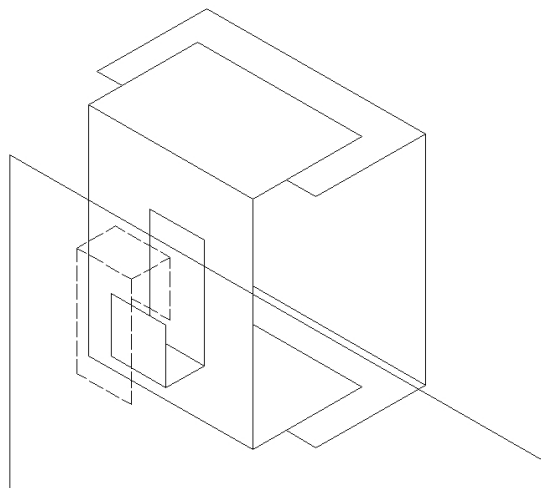

Figure 1: Example of cladding kit.

The substrate walls are made of masonry (clay, concrete or stone), concrete (cast on site or as prefabricated panels), timber or metal frame.

An insulation layer may be fixed onto the substrate. Between the cladding elements and/or the insulation layer there is an air space that shall be drained and may be ventilated or not.

The cladding elements provide enhanced watertightness protection but they are not intended to ensure airtightness of the building. The cladding elements are non load-bearing elements and do not contribute to the stability of the substrate.

This EAD does not cover panels whenever their maximum manufacturing dimensions are smaller than 800 mm.

This EAD does not cover external suspended ceilings. All kits containing non vertical parts are excluded.

¹ "Kit" means a construction product placed in the market by a single manufacturer as a set of at least two separate components that need to be put together to be incorporated in the construction works (Art. 2 n° 2 CPR).

Methods and criteria established in the following ETA Guidelines referred to in Art 66 (3) of the Regulation (EU) No 305/2011 cannot be appropriately used: ETAG 034 (April 2012). ETAG 034 defines the subframe as an intermediate assembly of vertical and/or horizontal, wood or metal profiles, located between the cladding elements and the substrate, and in this EAD the subframe has not vertical and/or horizontal profiles and the defined non-continuous metallic system does not belong to any cladding family. Moreover ETAG 034 (April 2012) does not foresee appropriate assessment methods for honeycomb panels, sandwich panels with two exterior metallic skins with coating and an internal honeycomb core .

Concerning product packaging, transport, storage, maintenance, replacement and repair it is the responsibility of the manufacturer to undertake the appropriate measures and to advise his clients on the transport, storage, maintenance, replacement and repair of the product as he considers necessary.

It is assumed that the product will be installed according to the manufacturer's instructions or (in absence of such instructions) according to the usual practice of the building professionals.

Relevant manufacturer's stipulations having influence on the performance of the product covered by this European Assessment Document shall be considered for the determination of the performance and detailed in the ETA.

1.2 Information on the intended use of the construction product

1.2.1 Intended use

This EAD covers the intended use of external wall claddings in ventilated façades (rainscreens) to be fixed to external vertical walls made of masonry (clay, concrete or stone), concrete (cast on site or as prefabricated panels), timber or metal frame in new or existing buildings (retrofit).

1.2.2 Working life/Durability

The assessment methods included or referred to in this EAD have been written based on the manufacturer's request to take into account a working life of the cladding kit made of metallic honeycomb panel for the intended use of 25 years when installed in the works. These provisions are based upon the current state of the art and the available knowledge and experience.

When assessing the product the intended use as foreseen by the manufacturer shall be taken into account. The real working life may be, in normal use conditions, considerably longer without major degradation affecting the basic requirements for works².

The indications given as to the working life of the construction product cannot be interpreted as a guarantee neither given by the product manufacturer or his representative nor by EOTA when drafting this EAD nor by the Technical Assessment Body issuing an ETA based on this EAD, but are regarded only as a means for expressing the expected economically reasonable working life of the product.

1.3 Specific terms used in this EAD

1.3.1 Cladding kit

A cladding kit is a specific kit composed by a metallic honeycomb panel as cladding element, its cladding fixings and a non-continuous metallic subframe, which is used as rainscreen of external walls.

1.3.2 Substrate

The term "substrate" refers to a wall, which in itself already meets the necessary airtightness and mechanical strength requirements (resistance to static and dynamic loads), as well as a relevant watertightness and water vapour resistance. The substrate walls can be made of masonry (clay, any kind of concrete or stone), concrete (cast on site or as prefabricated panels), timber or metal frame.

² The real working life of a product incorporated in a specific works depends on the environmental conditions to which that works is subject, as well as on the particular conditions of the design, execution, use and maintenance of that works. Therefore, it cannot be excluded that in certain cases the real working life of the product may also be shorter than referred to above.

1.3.3 Non-continuous subframe

An intermediate assembly of metal pieces (including the fixings between them) located between the cladding element and the substrate. The connection between a panel fixing and its adjacent occurs only through the cladding element.

1.3.4 Cladding element

Panel made of two exterior metallic skins with coating and an internal metallic honeycomb core applied at the external face of an external wall.

1.3.5 Cladding fixing

Screws/anchors, nails, rivets or any special fixing devices used to secure the cladding element to the non-continuous subframe.

1.3.6 Coating

Factory applied coat which generally contributes to the aesthetic finishing of the cladding element and can also provide supplementary protection against weathering.

1.3.7 Air space

It is the space between the cladding and the insulation layer or the substrate accordingly.

1.3.8 Ventilated air space

A layer of air between the substrate or insulation layer and cladding elements connected to the external environment permitting the dry-out of the water that may be found in this space due to condensations or rain penetration and the water vapour diffusion from the internal side of the wall.

External wall claddings are considered as ventilated when the following criteria are fulfilled:

- The distance between the cladding elements and the insulation layer or the substrate accordingly (ventilation air space) amounts to at least 20 mm. This air space may be reduced locally to 5 to 10 mm depending on the cladding and the subframe, provided that it is verified that it does not affect the draining and/or ventilation function,
- Ventilation openings are envisaged, as a minimum, at the building base point and at the roof edge with cross-sections of at least 50 cm² per linear metre.

1.3.9 Open joints

Space between the panels to allow:

- Ventilation of the ventilated air spaces.
- Thermal expansion of the individual panels.

2 ESSENTIAL CHARACTERISTICS AND RELEVANT ASSESSMENT METHODS AND CRITERIA

2.1 Essential characteristics of the product

Table 1 shows how the performance of cladding kit is assessed in relation to the essential characteristics.

Table1 Essential characteristics of the product and methods and criteria for assessing the performance of the product in relation to those essential characteristics

No	Essential characteristic	Assessment method	Type of expression of product performance
Basic Works Requirement 2: Safety in case of fire			
1	Reaction to fire	2.2.1	Class
Basic Works Requirement 3: Hygiene, health and the environment			
2	Watertightness of joints	2.2.2	Description
3	Drainability	2.2.3	Description
Basic Works Requirement 4: Safety and accessibility in use			
4	Wind load resistance	2.2.4	Level
5	Compression strength of cladding element	2.2.5	Level
6	Tensile strength of cladding element	2.2.6	Level
7	Peeling strength of cladding element	2.2.7	Level
8	Shear strength and force-deflection coefficient of cladding element	2.2.8	Level
9	Mechanical resistance of the combination of fixing devices	2.2.9	Level
10	Shear resistance of fixing from panel	2.2.10	Level
11	Combined tension and shear resistance of fixing from panel	2.2.11	Level
12	Resistance to horizontal point loads	2.2.12	Description
13	Resistance to impact (shatter properties)	2.2.13	Level
14	Pulsating load	2.2.14	Level
15	Corrosion of cladding element	2.2.15	Description
16	Corrosion of metal components (except cladding element)	2.2.16	Description
17	Resistance to ageing by UV radiation of cladding element	2.2.17	Level
18	Resistance to thermal shock	2.2.18	Level
19	Durability of the adherence of the honeycomb to the sheets	2.2.19	Level

2.2 Methods and criteria for assessing the performance of the product in relation to essential characteristics of the product

2.2.1 Reaction to fire

Reaction to fire of the whole kit shall be assessed by considering the reaction to fire of the components (cladding element, cladding fixings and non-continuous subframe components), in order to be classified according to Commission Delegated Regulation (EU) 2016/364.

Criteria and mounting and fixing rules for the SBI test indicated in EOTA TR 039, Section A shall be taken into account under consideration of the following clarifications:

- Coatings shall be grouped by PCS-value, in which case the kit with the highest PCS-value coating expressed as MJ/m² shall be subjected to SBI-testing. If the coating to the front and reverse face varies, the kit with the highest PCS-value coatings in both faces in MJ/m² shall be subjected to SBI-testing. The test shall be conducted on specimens of the darkest, the lightest and mid-range (e. g. red) color or on the specimen with the highest PCS-value coating (MJ/m²). This shall be decided by the TAB experience and the criterion shall be described in the Evaluation Report.
- Adhesives shall be grouped by PCS-value, in which case the kit with the highest PCS-value adhesive in MJ/m² shall be subjected to SBI-testing.
- The test substrate shall be compliant with EN 13238.
- If joints are considered in the test assembly, the widest joint shall be tested.
- The provision for sealing the corner detail between the long and the short wing with an A1 classified material do not apply.
- In order to classify the kit, ISO 1716 shall be applied to all non-metallic components and EN ISO 11925-2 shall be applied to the non-folded cladding element. According to EN 11925-2 the flame is applied in the following order:
 - ✓ On both faces of the cladding element (if different),
 - ✓ On the border of the inferior edge (in both faces, if different)
 - ✓ The specimen is then turned 90° and the flame is applied on each of the layers, for instance, on the external metallic sheet, the adhesive and the honeycomb, the adhesive and the internal metallic sheet.
- Deviating from figures A.1 and A.2 of TR 039 the cladding element shall be mounted punctually using the metallic fixing devices as foreseen for the kit in such way that sufficient air supply is assured from the lateral edges to the ventilation cavity on both wings of the specimens. EN 13823, clause 4.4.11, shall be considered for testing purposes.

The metal cladding fixings and the metal non-continuous subframe components are considered to satisfy the requirements for performance class A1 of the characteristic reaction to fire, in accordance with the provisions of EC Decision 1996/603/EC (as amended) without the need for testing on the basis of its listing in that Decision.

When relevant, reaction to fire of the rear side of the cladding element may also be tested using the test method(s) relevant for the corresponding reaction to fire class, in order to be classified according to Commission Delegated Regulation (EU) 2016/364.

2.2.2 Watertightness of joints (protection against driving rain)

The assessment of watertightness of joints is intended to determine two requirements of the cladding kit:

- Water running down the wall shall not reach the inside face of the wall.
- Materials likely to be adversely affected by water (fixings subject to corrosion, adhesives, etc.) shall not become damp.

Cladding kits with open joints shall be described as “not watertight”³.

Cladding kits with close joints contribute to the watertightness of the wall. In this case, the watertightness of the cladding kit shall be determined by testing according to EN 12865 Procedure A (see also Annex B). At least the worst case shall be tested (e.g. maximum number of joints).

The limit level of pressure (e.g. just before water penetration) shall be given in the ETA.

Additionally, the ETA shall include the relevant design details provided by the manufacturer, regarding the connections of the cladding kit with the roof edge, base edge and openings (windows or doors), related with the watertightness level declared by the manufacturer.

2.2.3 Drainability

The assessment of drainability is intended to determine whether water which penetrates in the air space or condensation water is drained out of the installed cladding kit without accumulation or moisture damage or leakage into the substrate or the cladding kit.

This assessment shall be carried out by description of the relevant design details provided by the manufacturer, regarding the cladding fixings geometry and the connections of the cladding kit with the base edge, openings (windows or doors). These design details shall be included in the ETA.

2.2.4 Wind load resistance

The wind load resistance (suction and/or pressure) of assembled systems shall be carried out by calculation taking into account the mechanical resistances of the kit components (cladding elements, cladding fixings and non-continuous subframe components) obtained from sections 2.2.6 to 2.2.12.

At least the worst case (the mechanically weakest case) or the more representative case of the assembled system shall be considered.

Relevant elasticity and resistance equations and relevant standards (e.g. EN 1999-1-1 for aluminium) should be considered for the calculation (at ultimate and serviceability limit states).

At least for one assembled system, the calculated result shall be contrasted by testing according to the method indicated in Annex C.

The assessment shall be based on the mechanical characteristics of the components (see sections 2.2.6 to 2.2.11) taking into account the results of the wind suction and/or pressure tests. In this case, if the test results obtained do not confirm the results obtained by mechanical tests of the kit components, at least two other test specimens have to be tested or the mechanical resistance of the kit components shall be corrected accordingly.

The wind load resistance for the cladding kit assembled systems shall be indicated.

³ When the joints are not watertight, the first layer behind ventilated air space (e.g. insulation layer) should be composed by materials with low water absorption (e.g. insulation products made of MW acc. to EN 13162, EPS acc. to EN 13163, XPS acc. to EN 13164, PUR acc. to EN 13165 and PF acc. to EN 13166), according to the national regulations in force.

2.2.5 Compression strength of cladding element

The compression strength of the metallic honeycomb panel as cladding element shall be determined as specified in Annex D. The mean value and the characteristic value according to Annex D shall be indicated.

2.2.6 Tensile strength of cladding element

The tensile strength of the adherence of the honeycomb to the metallic skins shall be determined as specified in Annex E. The mean value and the characteristic value according to Annex E shall be indicated.

2.2.7 Peeling strength of cladding element

The peeling strength of the honeycomb to the metallic skins shall be determined as specified in Annex F. The mean value and the characteristic value according to Annex F shall be indicated.

2.2.8 Shear strength and force-deflection coefficient of cladding element

The shear strength and the force-deflection coefficient of the metallic honeycomb panel as cladding element shall be determined as specified in Annex G. The mean value and the characteristic value of the shear strength and the force-deflection coefficient according to Annex G shall be indicated.

2.2.9 Mechanical resistance of the combination of fixing devices

The mechanical resistance of the combination of fixing devices shall be determined as specified in Annex H. At least the worst case (the mechanically weakest case) shall be tested. The mean value and the characteristic value according to Annex H shall be indicated.

2.2.10 Shear resistance of fixing from panel

The shear resistance of fixing from panel shall be determined as specified in Annex I. At least the worst case (the mechanically weakest case) shall be tested. The mean value and the characteristic value according to Annex I shall be indicated.

2.2.11 Combined tension and shear resistance of fixing from panel

The combined tension and shear resistance of the fixings from the panel shall be determined as specified in Annex J. At least the worst case (the mechanically weakest case) shall be tested. The mean value and the characteristic value according to Annex J shall be indicated.

If the failure mode does not change from pull-out of the fixing element or cone failure to bending failure using the ring with the maximum diameter, that is, the distance between fixings on the cladding element, the combined tension and shear resistance of fixing from panel shall be declared as “no bending”.

2.2.12 Resistance to horizontal point loads

Where required, the behaviour when tested for horizontal static load in service (ladder bearing against it) shall be checked. At least the worst case (the mechanically weakest case) or the more representative case of the assembled system shall be considered.

The cladding shall sustain safely, without reduction in performance and without permanent deformation to any component, a static 500 N load applied one minute horizontally through two squares of 25 x 25 x 5 mm spaced apart (distance 440 mm) on any part of the surface of the cladding (one person standing on a ladder leaning against the surface of the cladding) at room temperature.

The cladding element shall be capable of accommodating the horizontally applied loads acting on its surface arising from maintenance without any permanent deflection (no visible deformation).

2.2.13 Impact resistance

The external impact resistance shall be tested according to the method indicated in Annex K.

The hard body and soft body impact resistance shall be indicated.

Additionally, the degree of exposure according the use categories defined in the table K.2 of Annex K can be described.

2.2.14 Pulsating load

The pulsating load resistance of cladding fixing shall be determined as specified in Annex L. The mean value and the characteristic value according to Annex L shall be indicated.

2.2.15 Corrosion of cladding element

The corrosion protection of the cladding element shall be described according to the appropriate EN standard, for example, e.g.

- EN 1396 Aluminium and aluminium alloys - Coil coated sheet and strip for general applications - Specifications.
- EN ISO 9227 Corrosion tests in artificial atmospheres - Salt spray tests

If there is not appropriate EN standard the technical assessment body shall assess the evolution of the relevant characteristics (e.g. coated zinc sheet: appearance of ferric salts).

2.2.16 Corrosion of metal components (except cladding element)

The corrosion protection of the fixing devices and the metallic pieces shall be described according to the appropriate EN standard, e. g.

- EN ISO 898-1 Mechanical properties of fasteners made of carbon steel and alloy steel – Part 1: Bolts, screws and studs.
- EN ISO 3506-1 Mechanical properties of corrosion-resistant stainless-steel fasteners – Part 1: Bolts, screws and studs.
- EN 1670 Building hardware – Corrosion resistance – Requirements and test methods

The steel, aluminium and stainless steel grade has to be defined as a function of the field of application (e.g. marine atmosphere or industrial atmosphere).

In particularly aggressive atmosphere with extreme chemical pollution (e.g. desulphurisation plants, chloride atmosphere), special measures of corrosion protection shall be foreseen.

If the fixing devices and the metallic pieces are to be used in particularly aggressive atmosphere with extreme chemical pollution (e.g. in desulphurization plants or chloride atmosphere) the execution of

corresponding tests will be required taking account of the relevant environmental conditions and of current experience.

2.2.17 Resistance to ageing by UV radiation of cladding element

The test is required for claddings with a coating known to be sensitive to UV radiation such as polyester or other plastics.

The exposure to laboratory light sources shall be carried out according to the appropriate EN standard, e.g.

- EN 10169 Continuously organic coated (coil coated) steel flat products – Technical delivery conditions
- EN 12523-10 Coil coated metals - Test methods - Part 10: Resistance to fluorescent UV radiation and water condensation
- EN ISO 16474-2 Paints and varnishes - Methods of exposure to laboratory light sources - Part 2: Xenon-arc lamps

After ageing test, the color difference, gloss difference and chalking shall be determined according to the appropriate EN standard, e.g.

- color difference according to EN 13523-3
- gloss difference according to EN 13523-2
- chalking according to EN 13523-14

2.2.18 Resistance to thermal shock

The resistance to thermal shock of the kit shall be determined as specified in Annex M. The change of deflection, the local and total panel flatness from the initial values to the values at the end of the tenth cycle according to Annex M shall be indicated.

2.2.19 Durability of the adherence of the honeycomb to the sheets

The durability of the adherence of the honeycomb to the metallic sheets shall be tested according to the method indicated in Annex N. The change of shear strength in percentage after each exposure according to Annex N shall be indicated.

3 ASSESSMENT AND VERIFICATION OF CONSTANCY OF PERFORMANCE

3.1 System(s) of assessment and verification of constancy of performance to be applied

For the products covered by this EAD the applicable European legal act is: Decision 2003/640/EC

The system is: **2+**

In addition, with regard to e.g. reaction to fire for products covered by this EAD the applicable European legal act is: Decision 2003/640/EC

The systems are: **1, 3 or 4.**

3.2 Tasks of the manufacturer

The cornerstones of the actions to be undertaken by the manufacturer of the product in the procedure of assessment and verification of constancy of performance are laid down in Table 2.

Table 2 Control plan for the manufacturer; cornerstones

No	Subject/type of control	Test or control method	Criteria, if any	Minimum number of samples	Minimum frequency of control	
Factory production control (FPC) [including testing of samples taken at the factory in accordance with a prescribed test plan]*						
1	Metallic honeycomb cladding element					
	- Coil (including solid content / ash content and coverage of the coating)	Supplier certificates	Acc. to the values specified by the manufacturer	Testing is not required	Each coil	
	Colour, thickness and width	Measuring		Acc. Control Plan		
	- Adhesive (including solid content / ash content)	Supplier certificates		Testing is not required	Each delivery	
	- Honeycomb	Supplier certificates		Testing is not required	Each delivery	
	- Coating direction	Visual check			Each coil change	
	- Coating condition	Visual check			Continuous	
	- Geometry (form and dimensions)	Measuring			Each order, coil change or thickness change	
	- Adherence	Manual check				
	- Dent inspection	Visual check			Acc. Control Plan	Continuous
	- Spreading rate of adhesive (mass per area)	Measuring				
	- Peeling resistance	§2.2.8				Each order
	- Gross heat of combustion (Adhesive and coating)	EN ISO 1716				At least once each 2 years
- SBI	EN 13823				Only when PCS value of adhesive or coating is higher than ITT	
2	Non-continuous metallic subframe and its associated fixing devices:					
	- Material	Supplier certificates	Acc. to the values specified by the manufacturer	Testing is not required	Each delivery	
	- Geometry (form and dimensions)	Supplier certificates		Testing is not required	Each delivery	

No	Subject/type of control	Test or control method	Criteria, if any	Minimum number of samples	Minimum frequency of control
	- Mechanical characteristics	§Annex H		Acc. Control Plan	At least once each 5 years

3.3 Tasks of the notified body

The cornerstones of the actions to be undertaken by the notified body in the procedure of assessment and verification of constancy of performance for the kits for ventilated external wall claddings with metallic honeycomb panels are laid down in Table 3.

Table 3 Control plan for the notified body; cornerstones

No	Subject/type of control	Test or control method	Criteria, if any	Minimum number of samples	Minimum frequency of control
Initial inspection of the manufacturing plant and of factory production control					
1	The notified body shall verify the ability of the manufacturer for a continuous and orderly control of the product according to the European Technical Assessment. In particular the following items shall be appropriately considered <ul style="list-style-type: none"> - personnel and equipment - the suitability of the factory production control established by the manufacturer - full implementation of the prescribed Control Plan 				---
Continuous surveillance, assessment and evaluation of factory production control					
2	The notified body shall verify that <ul style="list-style-type: none"> - the manufacturing process of the metallic honeycomb panels - the system of factory production control - the implementation of the prescribed Control Plan are maintained.				Once per year

4 REFERENCE DOCUMENTS

As far as no edition date is given in the list of standards thereafter, the standard in its current version at the time of issuing the European Technical Assessment is of relevance.

EOTA TR001	Determination of impact resistance of panels and panel assemblies
EOTA TR039	Ventilated façade system with self-supporting composite panels
EN 410	Glass in building - Determination of luminous and solar characteristics of glazing
EN 755-1	Aluminium and aluminium alloys- Extruded rod/bar, tube and profiles - Part 1: Technical conditions for inspection and delivery
EN 755-2	Aluminium and aluminium alloys - Extruded rod/bar, tube and profiles - Part 2: Mechanical properties
EN 826	Thermal insulating products for building applications - Determination of compression behaviour
EN ISO 898-1	Mechanical properties of fasteners made of carbon steel and alloy steel – Part 1: Bolts, screws and studs.
EN 1396	Aluminium and aluminium alloys - Coil coated sheet and strip for general applications – Specifications
EN 1607	Thermal insulating products for building applications - Determination of tensile strength perpendicular to faces
EN 1670	Building hardware - Corrosion resistance - Requirements and test methods
EN ISO 1716	Reaction to fire tests for products - Determination of the gross heat of combustion (calorific value)
EN 1999-1-1	Eurocode 9: Design of aluminium structures - Part 1-1: General structural rules
EN 2243-3	Aerospace series - Non-metallic materials - Structural adhesives - Test method - Part 3: Peeling test metal-honeycomb core
EN ISO 3506-1	Mechanical properties of corrosion-resistant stainless-steel fasteners – Part 1: Bolts, screws and studs.
EN ISO 9227	Corrosion tests in artificial atmospheres - Salt spray tests
EN 10169	Continuously organic coated (coil coated) steel flat products – Technical delivery conditions
EN 10088-1	Stainless steels - Part 1: List of stainless steels
EN 10088-2	Stainless steels - Part 2: Technical delivery conditions for sheet/plate and strip of corrosion resisting steels for general purposes
EN ISO 11925-2	Reaction to fire tests - Ignitability of products subjected to direct impingement of flame - Part 2: Single-flame source test
EN 12865	Hygrothermal performance of building components and building elements - Determination of the resistance of external wall systems to driving rain under pulsating air pressure.
EN 13238	Reaction to fire tests for building products - Conditioning procedures and general rules for selection of substrates
EN 13501–1	Fire classification of construction products and building elements, part 1: Classification using data from reaction to fire tests

EN 13523-2	Coil coated metals - Test methods - Part 2: Gloss
EN 13523-3	Coil coated metals - Test methods - Part 3: Colour difference - Instrumental comparison
EN 13523-10	Coil coated metals - Test methods - Part 10: Resistance to fluorescent UV radiation and water condensation
EN 13523-14	Coil coated metals - Test methods - Part 14: Chalking (Helmen method)
EN 13964	Suspended ceilings - Requirements and test methods
EN 14509	Self-supporting double skin metal faced insulating panels - Factory made products - Specifications
EN ISO 16474-2	Paints and varnishes - Methods of exposure to laboratory light sources - Part 2: Xenon-arc lamps

ANNEX A – DESCRIPTION OF THE COMPONENTS

The kit components should be defined in the ETA by means of the following characteristics and references:

A.1 Metallic honeycomb cladding elements

- Dimensions (thickness, length and width) and tolerances.
- Form (flatness, angles and special shapes) and tolerances.
- Density and tolerances.
- Compression strength ⁴.
- Tensile strength ⁴.
- Peeling strength ⁴.
- Shear strength and force-deflection coefficient ⁴.
- Type of material (Metal alloy for sheets and honeycomb).
- Type of coating.
- Cell dimensions and sheet thickness for honeycomb core.
- Type of adhesive.

A.2 Fixings and metallic pieces (acc. to the relevant standards EN 1999-1-1, EN 755-1, EN 755-2, EN 10088-1, EN 10088-2, etc.)

- Geometric and physical characteristics:
 - Form and dimensions.
 - Weight per linear metre or per unit.
 - Cross section in the case of pieces.
 - Inertia of the section in the case of pieces.
- Material properties:
 - Type of material.
 - Specific gravity.
 - Elastic limit.
 - Elongation.
 - Tensile strength.
 - Modulus of elasticity (at 20°C).
 - Poisson coefficient.
 - Thermal expansion coefficient between 50 °C and 100 °C.

⁴ Characteristics also indicated in section 2.

ANNEX B – ADDITIONAL CRITERIA FOR WATERTIGHTNESS TESTS

A translucent panel (PMMA thickness 8 mm) with 3 mm diameter holes (0,01 % holes) could be placed behind the cladding (see Figure B.2 and Figure B.3).

For example, if the size of sample is 2,400 mm x 1,200 mm, the display of holes could be made according to Figure B.1.

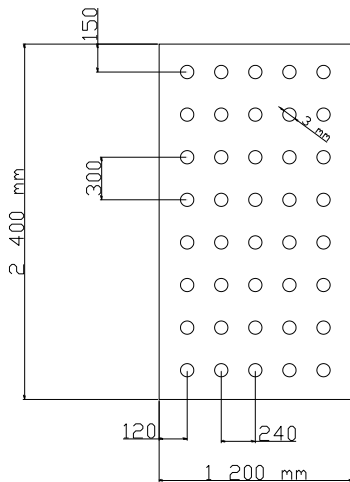

Figure B.1: Example of distances between holes.

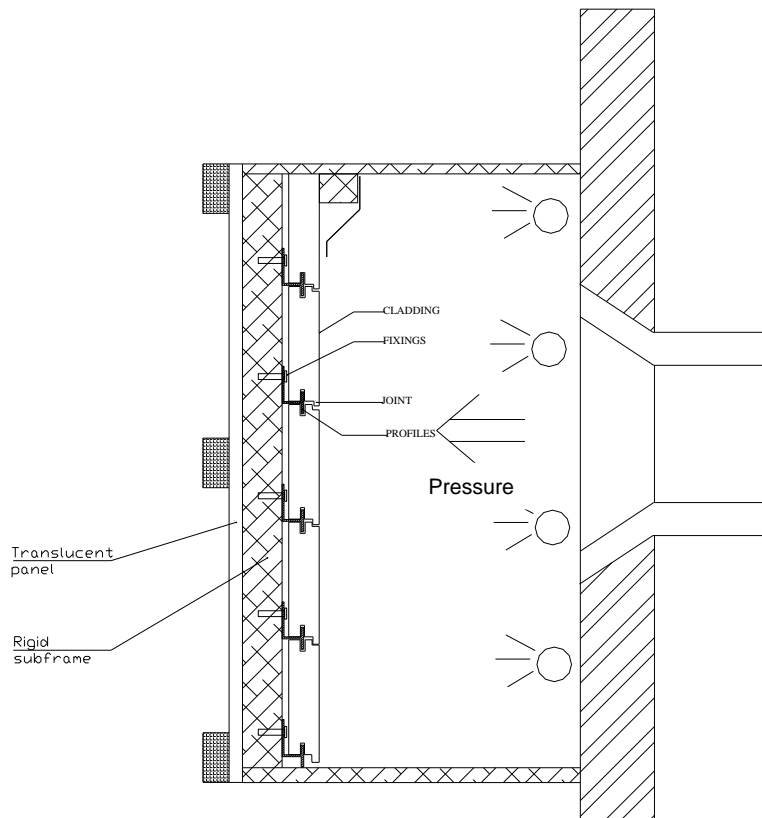

Figure B.2: Example of test device – vertical section.

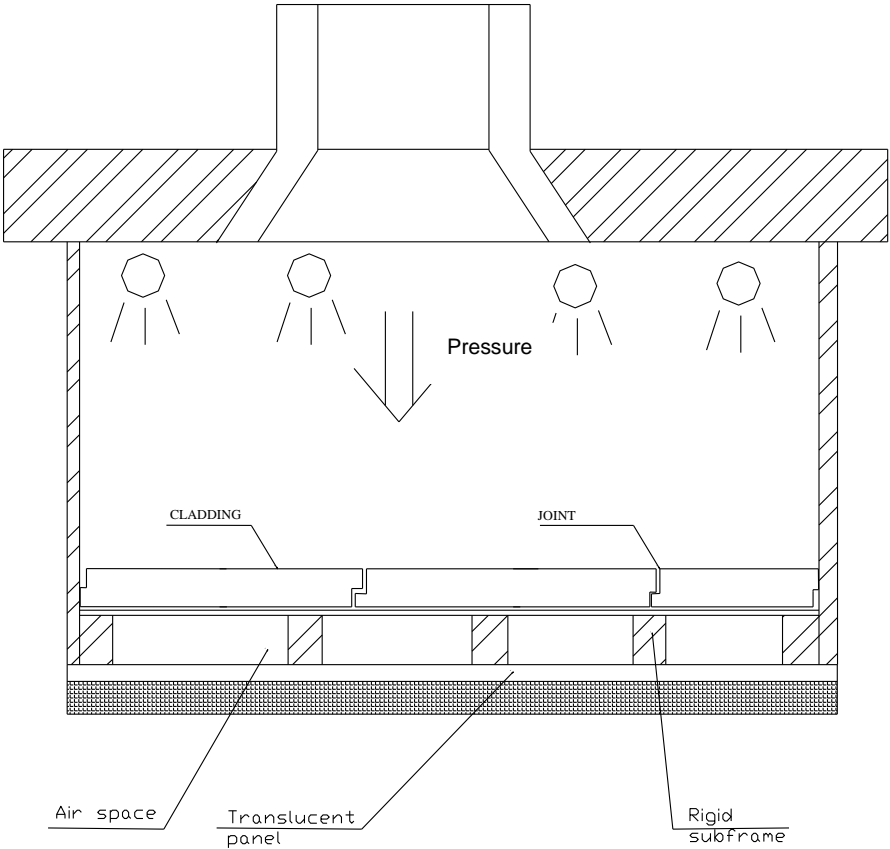

Figure B.3: Example of test device – horizontal section.

ANNEX C – WIND SUCTION AND PRESSURE LOADS TESTS

The principle is to establish the effects of suction and pressure loads on the assembled system.

The number of tests depends on the combination of parameters presented for the assembled systems.

As a minimum, the mechanically weakest design shall be tested.

C.1 Wind suction test

C.1.1 Preparation of the test specimen

The test specimen shall be mounted in the test equipment in accordance with the manufacturer instructions.

The test specimen is defined as follows:

- A non airtight substrate (test rig) such as wood or steel rigid frame.
- The assembled system must be fixed to the test rig.
- The dimensions of the test specimen depend on the size of external cladding element and the specified cladding fixings :
 - For cladding elements which are mechanically fixed independent of each other, a minimum surface cladding of 1,5 m² shall be tested.
 - If they depend on each other vertically and horizontally, at least 3 x 3 elements shall be tested.
 - If they depend on each other vertically or horizontally, at least 4 elements shall be tested.

To define the mechanically weakest design the following aspects shall be taken into account:

- The mechanically weakest cladding element (e.g. minimum thickness, minimum bending strength, etc.)
- Minimum density of cladding fixings.
- Maximum span between non-continuous subframe pieces.

The tolerances due to manufacturing and/or installation and deformations due to temperature and humidity variations have to be taken into account.

C.1.2 Test equipment

The test equipment consists of a pressure or suction chamber (see Figure C.1) against which is placed the assembled system. The depth of chamber shall be sufficient for a constant pressure or suction to be exerted on the test specimen applied to the external surface of the assembled system irrespective of its possible deformation. The chamber is mounted on a rigid frame. The assembled system acts as the seal between the chamber and the environment. The connection between the assembled system and the chamber shall be sufficient to allow a realistic deformation of the test specimen under the influence of simulated wind suction.

Alternative test equipment

The alternative test may be used, provided that the geometric shape allows the foil bags to be placed in the air space and be blown out so that a uniformly distributed pressure load at the rear face of the cladding is possible.

The test rig consists of a rigid frame (steel construction) made of vertical longitudinal girder and horizontal profiles (anchor channel) and rigid boards or a massive wall such as masonry or concrete.

The subframe of the cladding kit has to be fixed on the rig and the cladding elements have to be fixed on the subframe according to the indications given by the ETA holder.

The vertical profiles of the rig can be movable (sliding) so that they can be placed in the axis of the fixings of the cladding.

Foil bags which are placed in the air space at the rear side of the cladding are blown out and they exert a uniformly distributed pressure load on the rear face of the cladding which corresponds to the wind suction load.

C.1.3 Test procedure

The uniformly distributed loads are exerted on the surface of the assembled system.

The test is performed in successive steps (two steps of 300 Pa, one step of 500 Pa and one step of 1,000 Pa, then steps of +200 Pa thereafter, at each step the load is maintained constant for at least 10 seconds and returned to zero after each step; see Figure C.2) until significant irreversible deformation (deformation which affects serviceability) or failure occurs.

The test is then continued until failure occurs.

The deflection shall be measured, at the relevant points (e.g. central point of the cladding element, border or corner of the cladding element, cladding fixing, etc.), as a function of the load and reported in tabular or graphic form.

With the differential pressure reduced to zero, the permanent deflection shall be noted after 1 minute recovery. The pressure at which defect or damage occur shall be noted.

Additionally, if relevant, the permanent deflection 1 hour after failure occurs shall be noted.

The fixings between the assembled system and the test equipment shall not constitute weak points and shall therefore be chosen accordingly.

C.1.4 Observations during the test

Failure is defined by any one of the following events:

- Any cladding element breaks,
- Any cladding element presents a significant permanent deflection,
- The failure of fixings (e.g. pull out, deformation, breakage)
- The failure or detachment of the subframe of the kit.

C.1.5 Test results

The test result is:

- the failure load Q ,
- the type of failure
- and the value of maximum deflection.

In addition, the points of measurement shall be indicated on a drawing of the test specimen and the deflections at each measurement point shall be tabulated for each suction step.

C.1.6 Test specimen description

It is necessary to describe the test specimen by giving details about:

- Cladding elements: geometry and dimensions
- Fixing system

- Fixing density
- Subframe (material properties, section, distance between the supports).

C.2 Wind pressure test

The test procedure is similar to C.1, the only difference being that the wind action is reversed.

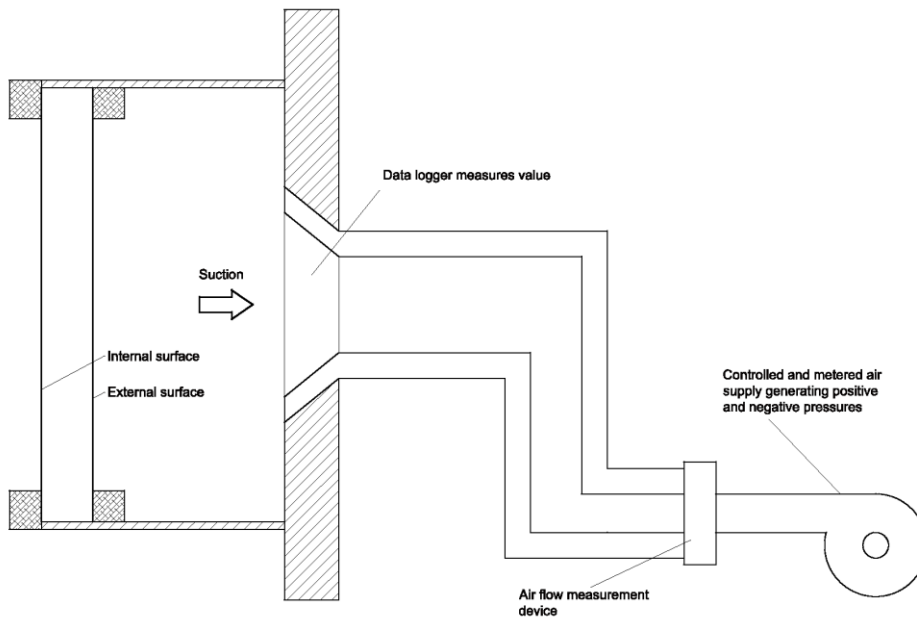

Figure C.1: Example of wind pressure and suction apparatus.

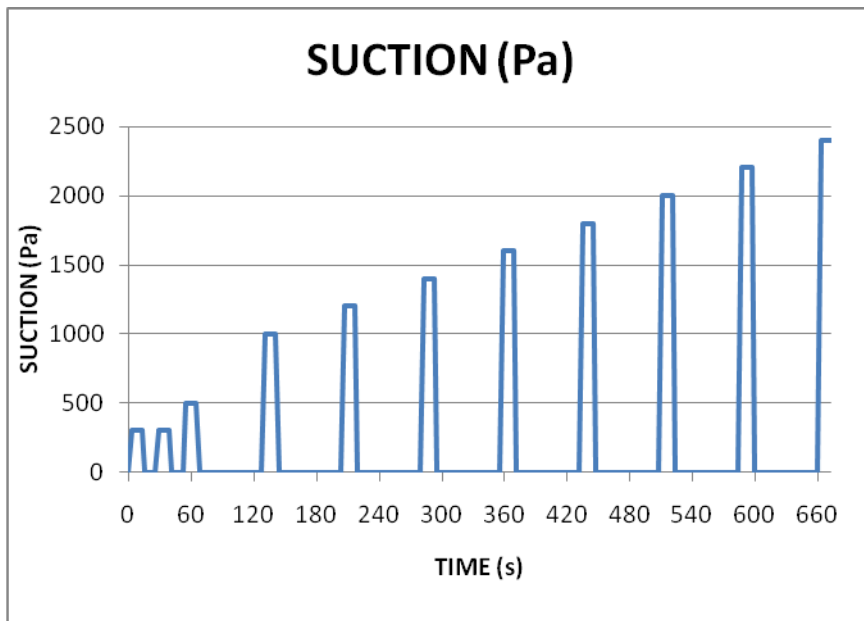

Figure C.2: Example of wind load steps.

ANNEX D – COMPRESSION STRENGTH OF THE CLADDING ELEMENT

D.1 Principle

A compressive force is applied at a given rate of displacement in axial direction perpendicular to the panel consisting of the honeycomb on both sides adhered to a metallic skin.

The ultimate load at failure of the honeycomb shall be measured and recorded.

From this ultimate load at failure the compression strength shall be calculated.

The test specimen is taken from a standard production panel comprising of a honeycomb on both sides adhered to a metallic skin.

D.2 Apparatus

The apparatus shall be a compression testing machine in accordance with clause 5 of EN 826.

The movable plate shall be capable of moving at a constant speed of displacement of $(d/10)$ mm per minute, whereby d is the thickness of the test specimen in mm.

D.3 Test specimen

The test specimens shall be taken from the panel after the adhesive has been completely cured.

The dimensions of the test specimen shall be

- length l : (75 ± 2) mm;
- width w : (75 ± 2) mm;
- thickness d : thickness in mm of the panel with a tolerance of ± 2 mm.

The number of test specimens shall be at least 5.

D.4 Conditioning

Prior to testing the test specimens shall be stored at a temperature of $(23 \pm 5)^\circ\text{C}$ for at least 12 hours.

D.5 Procedure

The test shall be carried out at a temperature of $(23 \pm 5)^\circ\text{C}$.

Measure the three dimensions of the test specimens in mm and calculate the initial area of cross section A_c in mm^2 .

Place the test specimen centrally between the two parallel plates of the compression testing machine.

Compress the test specimen with a loading rate of $(d/10)$ mm/minute.

The ultimate load F_c in kN at failure of the honeycomb shall be measured.

D.6 Expression of results

The value of the ultimate load in kN of each of the test specimens, F_c , shall be indicated.

The compressive strength of the honeycomb, σ_c in kPa, for each of the test specimens shall be calculated as follows.

$$\sigma_c = \frac{F_c}{A_c}$$

where:

F_c is the ultimate load, in kN;

A_c is the initial area of the cross section of the test specimen in mm².

The compressive strength of the honeycomb is the mean value of the compression strength of the test specimens and shall be indicated as σ_{cm} in kPa.

The 5 % fractile value, $\sigma_{cm,5\%}$, shall be calculated as follows.

$$\sigma_{cm,5\%} = \sigma_{cm} - k_n s$$

where:

$\sigma_{cm,5\%}$ is the 5% fractile value of the compressive strength of the honeycomb;

σ_{cm} is the mean value the compressive strength of the honeycomb of the test specimens in kPa;

k_n is the statistical factor (acceptance factor) in accordance with Annex O;

s is the standard deviation in kPa.

ANNEX E – TENSILE STRENGTH OF THE CLADDING ELEMENT

E.1 Principle

The tensile strength, σ_t , is the maximum recorded tensile force perpendicular to the metallic sheets during the pulling operation, divided by the cross-sectional area of the test specimen.

The test specimen, being a honeycomb glued between two metallic sheets, is attached between two rigid plates or blocks, fastened in a tensile testing machine and pulled apart at a given speed.

The maximum tensile force is recorded and the tensile strength of the test specimen is calculated.

E.2 Apparatus

The apparatus comprises the next elements:

- Tensile testing machine, appropriate for the range of force and displacement involved, capable of having a constant crosshead speed adjusted to 1,5 mm/min \pm 10 % and capable of measuring the force with an accuracy of \pm 1 %.
- Rigid plates or blocks with self aligning attachment to avoid uneven distribution of tensile stress during the test. Examples of a suitable arrangement to bond the test specimen are shown in figure 1 of EN 1607.
- Adhesive, used to bond the test specimen between the rigid plates or blocks.

E.3 Test specimen

The test specimen shall be a honeycomb which on both sides is adhered to a metallic skin.

The test specimens shall be taken from the panel after the adhesive has been completely cured.

The dimensions of the test specimen shall be

- length l : (75 \pm 2) mm;
- width w : (75 \pm 2) mm;
- thickness d: thickness in mm of the panel with a tolerance of \pm 2 mm.

The number of test specimens shall be at least 5.

E.4 Conditioning

Prior to testing the test specimens shall be stored at a temperature of (23 \pm 5) $^{\circ}$ C for at least 12 hours.

E.5 Procedure

The test shall be carried out at a temperature of (23 \pm 5) $^{\circ}$ C.

Measure the three dimensions of the test specimens in mm and calculate the initial area of cross section A_c in mm².

Attach the test specimen in the tensile testing machine by means of the plate/block fixings and increase the tensile force with a constant speed of 1,5 mm/min until failure occurs.

The load F_t in kN at failure shall be measured.

E.6 Expression of results

The value of the load at failure in kN of each of the test specimens, F_t , shall be indicated.

The tensile strength of the honeycomb, σ_t in kPa, for each of the test specimens shall be calculated as follows.

$$\sigma_t = \frac{F_t}{A_t}$$

where:

F_t is the load at failure, in kN;

A_t is the initial area of the cross section of the test specimen in mm².

The tensile strength of the adherence of the honeycomb to the metallic sheets is the mean value of the tensile strength of the test specimens and shall be indicated as σ_{tm} in kPa.

The 5 % fractile value, $\sigma_{tm,5\%}$, shall be calculated as follows.

$$\sigma_{tm,5\%} = \sigma_{tm} - k_n s$$

where:

$\sigma_{tm,5\%}$ is the 5% fractile value of the tensile strength of the adherence of the honeycomb to the metallic sheets;

σ_{tm} is the mean value the tensile strength of the honeycomb of the test specimens in kPa;

k_n is the statistical factor (acceptance factor) in accordance with Annex O;

s is the standard deviation in kPa.

ANNEX F – PEELING STRENGTH OF THE CLADDING ELEMENT

F.1 Principle

The peeling strength, σ_p , is the average value of the peeling force during the “peeling” operation divided by the width of the test specimen.

In contrast with the procedure as described in EN 2243-3 the value of “ F_0 ”, being the rolling load, has not been taken into account for the calculation of the peeling force. In this case the peeling force is to determine the “ $F_{0\text{ force}}$ ” of the panel.

The test specimen, being a honeycomb glued between two metallic sheets, is attached in a peeling jig which is fastened in a tensile testing machine and pulled apart.

The peeling load is recorded and the peeling strength is calculated.

F.2 Apparatus

The apparatus comprises the next elements:

- Tensile testing machine, appropriate for the range of force and displacement involved, capable of a constant crosshead speed adjusted to 25 mm/min \pm 10% and capable of measuring the force with an accuracy of \pm 1%.
- Peeling jig, in accordance with clause 6.1.2 of EN 2243-3 with a drum radius of 100 mm.
- Recorder, to measure continuously the displacement relative to the load applied in accordance with clause 6.1.3 of EN 2243-3.

F.3 Test specimen

The test specimen shall be a honeycomb which on both sides is adhered to a metallic skin.

The test specimens shall be taken from the panel after the adhesive has been completely cured.

The dimensions of the test specimen shall be

- length l: (350 \pm 2) mm;
- width w:(75 \pm 2) mm;

The number of test specimens shall be at least 5.

F.4 Conditioning

Prior to testing the test specimens shall be stored at a temperature of (23 \pm 5)°C for at least 12 hours.

F.5 Procedure

The test shall be carried out at a temperature of (23 \pm 5)°C.

Attach the test specimen in the peeling rig in such a way that at testing the unrolling will be from the inside. The “inside” being the upper sheet in the production process.

Adjust the peeling rig in the tensile testing machine.

The load shall be applied at a uniform jaws separation of 25 mm/min.

A minimum length of 150 mm shall be peeled.

Record the load-displacement curve (peeling diagram).

F.6 Expression of results

The value of the average peeling load at failure in N of each of the test specimens, F_p , shall be indicated.

The average peeling load, F_p , shall be determined over a peeling length of 125 mm, by inserting the estimated average value into the diagram as shown in figure 3 of EN 2243-3.

The results of the first 25 mm of the peel separation on the specimen as shown in the peeling diagram (figure 3 of EN 2243-3) after the first maximum load are to be excluded from the assessment of the average value.

In case of dispute the average peeling load shall be determined by means of a planimeter.

The peeling strength per test specimen of the honeycomb, τ_p , in N/mm, shall be calculated as follows.

$$\tau_p = \frac{F_p}{W}$$

where:

F_p is the average peeling load at failure, in N;

W is the width of the test specimen in mm.

The peeling strength is the mean value of the peeling strength of the test specimens and shall be indicated as τ_{pm} in N/mm.

The 5 % fractile value, $\tau_{pm,5\%}$, shall be calculated as follows.

$$\tau_{pm,5\%} = \tau_{pm} - k_n s$$

where:

$\tau_{pm,5\%}$ is the 5% fractile value of the peeling strength;

τ_{pm} is the mean value the peeling strength of the test specimens in N/mm;

k_n is the statistical factor (acceptance factor) in accordance with Annex O;

s is the standard deviation in kPa.

ANNEX G – SHEAR STRENGTH AND FORCE-DEFLECTION COEFFICIENT OF THE CLADDING ELEMENT

G.1 Principle

The force-deflection coefficient, FD_s , in shear is the difference in force measured at two loading levels divided by the difference in deflection at the same loading levels and expressed in kN/mm.

The force-deflection coefficient of specimen x , $FD_{s,x}$, is the arithmetic mean value of the force-displacement coefficient of four loading levels equally divided over the linear part of the load-deflection curve and divided by the corresponding deflections.

The average force-deflection coefficient, $FD_{s,av}$, is the arithmetic mean of the individual values of the y test specimens.

The force-deflection coefficient is a characteristic to indicate the bending stiffness of the panel.

The shear strength of the test specimen, σ_s , in kPa, being a honeycomb glued between two metallic sheets, is determined using a four-point bending test. The ultimate load carried by the specimen failing in shear shall be measured and the shear strength shall be calculated.

At four loading levels, equally divided over the linear part of the loading curve, the force-deflection coefficient, FD_s , in kN/mm, shall be calculated. From these four values the force-deflection coefficient of the specimen x , $FD_{s,x}$, shall be calculated.

G.2 Apparatus

The four-point bending test apparatus shall be in accordance with EN 14509 clause A.3.2 with a loading speed of 7,5 mm/min.

G.3 Test specimen

The test specimen shall be a honeycomb which on both sides is adhered to a metallic sheet.

The test specimens shall be taken from the panel after the adhesive has been completely cured.

The dimensions of the test specimen shall be

- length l : (800 ± 2) mm;
- width w : (150 ± 2) mm;
- thickness d : thickness of the honeycomb + t_i + t_o in mm, whereby t_i is the thickness of the inside metallic sheet and t_o is the thickness of the outside metallic sheet.

The number of test specimens shall be at least 5.

G.4 Conditioning

Prior to testing the test specimens shall be stored at a temperature of $(23 \pm 5)^\circ\text{C}$ for at least 12 hours.

G.5 Procedure

The test shall be carried out at a temperature of $(23 \pm 5)^\circ\text{C}$.

Measure the dimensions of the test specimen.

Place the test specimen in the four-point bending test apparatus as shown in EN 14509 Figure A.4 in such a manner that the thinnest metallic sheet is on the upper side.

The specimen shall be loaded with a loading rate 7,5 mm/min until failure.

During the test the deflection shall be measured with a precision of 1 %. The loading shall be continued until failure and a load-deflection curve shall be drawn.

The ultimate load, F_s , in kN at failure in shear shall be measured.

At four loads, equally divided over the linear part of the load-deflection curve the four concerning deflections shall be determined.

G.6 Expression of results

G.6.1 Shear strength

The value of the load at failure in kN of each of the test specimens, F_s , shall be indicated.

The shear strength per test specimen of the combination honeycomb/metallic sheets, σ_s , in kPa shall be calculated as follows.

$$\sigma_s = \frac{F_s}{2 \cdot w \cdot (d - 2 \cdot t_i - 2 \cdot t_o)}$$

where:

F_s is the load at failure, in kN;

w is the width of the test specimen in mm;

d is the thickness of the test piece in mm;

t_i is the thickness of the inside metallic sheet in mm;

t_o is the thickness of the outside metallic sheet in mm.

The shear strength of the adherence of the honeycomb to the metallic sheets is the mean value of the shear strength of the test specimens and shall be indicated as s_{sm} in kPa.

The 5 % fractile value, $s_{sm,5\%}$, shall be calculated as follows.

$$s_{sm,5\%} = s_{sm} - k_n s$$

where:

$s_{sm,5\%}$ is the 5% fractile value of the shear strength;

s_{sm} is the mean value the shear strength of the test specimens in kPa;

k_n is the statistical factor (acceptance factor) in accordance with Annex O;

s is the standard deviation in kPa.

G.6.2 Force-deflection coefficient

Per test specimen and two levels of load, F , with the respective deflections, ε , the force-deflection coefficient, FD_s in kN/mm, shall be calculated as follows.

$$FD_s = \frac{(F_n - F_{n-1})}{(\varepsilon_n - \varepsilon_{n-1})}$$

where:

F_n is the load at failure at loading level n , in kN;

F_{n-1} is the load at failure at loading level $(n-1)$, in kN;

ϵ_n is the deflection at loading level n, in mm;

ϵ_{n-1} is the deflection at loading level (n-1), in mm.

The force-deflection coefficient of test specimen x, $FD_{s,x}$, is the mean value of the calculated force-displacement coefficients.

The force-deflection coefficient is the mean value of the force-displacement coefficients of the test specimens and shall be indicated as $FD_{s,av}$ in kN/mm.

The 5 % fractile value, $FD_{s,av,5\%}$, shall be calculated as follows.

$$FD_{s,av,5\%} = FD_{s,av} - k_n s$$

where:

$FD_{s,av,5\%}$ is the 5% fractile value of the force-deflection coefficient;

$FD_{s,av}$ is the mean value the force-deflection coefficient of the test specimens in kN/mm;

k_n is the statistical factor (acceptance factor) in accordance with Annex O;

s is the standard deviation in kPa.

ANNEX H – MECHANICAL RESISTANCE OF THE COMBINATION OF FIXING DEVICES

H.1 Principle

The mechanical resistance of a combination of fixing devices, being:

- Cladding element to hook;
- Hanger to bracket (Metallic pieces and its fixings which are used to hang the cladding element);
- Bracket to bracket (Metallic pieces and its fixings which allow the fixings to the cladding element move horizontally, vertically and depth);

shall be determined by measuring the tensile load at failure (e.g. pull out, deformation, breakage) depending on the type of fixing device.

The combinations of fixing devices of the kit may be different (from those described above) as long as the metallic subframe of the kit is non-continuous.

H.2 Apparatus

The apparatus shall be a tensile testing machine, capable for a maximum force of 10 kN, capable of having a constant crosshead speed adjusted to 5 mm/min \pm 10 % and capable of measuring the force with an accuracy of \pm 1 %.

The clamps shall be such that they are self aligning to avoid uneven distribution of tensile stress during the test.

For not symmetrical or asymmetrical test specimens it is necessary to test two test specimens in “reflected image” to avoid bending during the test.

H.3 Test specimen

Per combination of fixing devices the number of test specimens shall be at least 5.

H.4 Conditioning

Prior to testing the test specimens shall be stored at a temperature of $(23 \pm 5)^\circ\text{C}$ for at least 12 hours.

H.5 Procedure

The test shall be carried out at a temperature of $(23 \pm 5)^\circ\text{C}$.

Indicate the test specimen being a combination of fixing devices.

Place the test specimen in the testing apparatus in such a way that during test there is no secondary bending. The test specimen shall be loaded with a tensile speed of 5 mm/min until failure.

The load F_t in kN at failure shall be measured.

H.6 Expression of results

The value of the load at failure in kN of each of the test specimens, F_t , shall be indicated.

The tensile load of the specific combination of fixing devices is the mean value of the test specimens and shall be indicated as F_{tm} in kN.

The 5 % fractile value, $F_{tm,5\%}$, shall be calculated as follows.

$$F_{tm,5\%} = F_{tm} - k_n s$$

where:

$F_{tm,5\%}$ is the 5% fractile value of the tensile load of the specific combination of fixing devices;

F_{tm} is the mean value the tensile load of the specific combination of fixing devices of the test specimens in kN;

k_n is the statistical factor (acceptance factor) in accordance with Annex O;

s is the standard deviation in kN.

ANNEX I – SHEAR RESISTANCE OF FIXING FROM CLADDING ELEMENT

I.1 General

The principle is to establish the shear resistance of the cladding fixing and the cladding element.

The fixing shall be installed as specified by the applicant. The shear load shall be applied on the fixing without eccentricity and without exposure to moments (Figure I.1).

I.2 Apparatus

The apparatus shall be a tensile testing machine, capable for a maximum force of 10 kN, capable of having a constant crosshead speed adjusted to 5 mm/min \pm 10 % and capable of measuring the force with an accuracy of \pm 1 %.

The clamps shall be such that they are self-aligning to avoid uneven distribution of tension stress during the test.

I.3 Test specimen

The number of test specimens shall be at least 5.

I.4 Conditioning

Prior to testing the test specimens shall be stored at a temperature of $(23 \pm 5)^\circ\text{C}$ for at least 12 hours.

I.5 Procedure

The test shall be carried out at a temperature of $(23 \pm 5)^\circ\text{C}$.

Place the test specimen in the testing apparatus in such a way that during test there is no tensile loading.

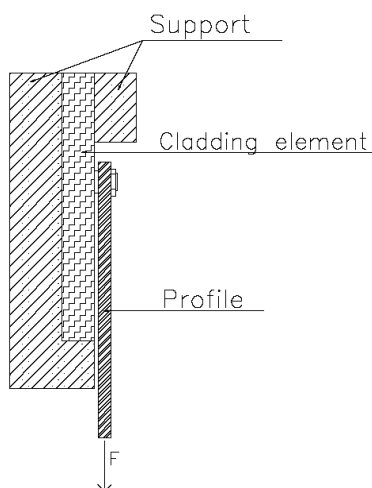

Figure I.1: Example of test of fixing.

The test specimen shall be loaded with a shear speed of 5 mm/min until failure.

The load F_s in kN at failure shall be measured.

I.6 Expression of results

The value of the load at failure in kN of each of the test specimens, F_s , shall be indicated.

The shear resistance of fixing from cladding element is the mean value of the shear resistance of the test specimens and shall be indicated as F_{sm} in kN.

The 5 % fractile value, $F_{sm,5\%}$, shall be calculated as follows.

$$F_{sm,5\%} = F_{sm} - k_n s$$

where:

$F_{sm,5\%}$ is the 5% fractile value of the shear resistance

F_{sm} is the mean value the shear strength of the test specimens in kN

k_n is the statistical factor (acceptance factor) in accordance with Annex O.

s is the standard deviation in kN

ANNEX J – COMBINED TENSION AND SHEAR RESISTANCE OF FIXING FROM CLADDING ELEMENT

J.1 General

The principle is to establish the combined tension and shear resistance of the cladding fixing and the cladding element.

The fixing shall be installed as specified by the applicant. The load shall be applied on the fixing without eccentricity.

J.2 Apparatus

The apparatus shall be a tensile testing machine, capable for a maximum force of 10 kN, capable of having a constant crosshead speed adjusted to 5 mm/min \pm 10 % and capable of measuring the force with an accuracy of \pm 1 %.

The clamps shall be such that they are self-aligning to avoid uneven distribution of stress during the test.

J.3 Test specimen

The number of test specimens shall be at least 5.

J.4 Conditioning

Prior to testing the test specimens shall be stored at a temperature of $(23 \pm 5)^\circ\text{C}$ for at least 12 hours.

J.5 Procedure

The test shall be carried out at a temperature of $(23 \pm 5)^\circ\text{C}$.

The direction of load shall correspond to an angle of 30° and 60° relative to the plane of the cladding element (Figure J.1).

The diameter of the supporting ring shall be changed, between for example $\varnothing 50$ and the maximum distance between fixings on the cladding element, in order to find out the diameter d_{ref} where the failure mode changes from pull-out of the fixing element or cone failure to bending failure of the test specimen

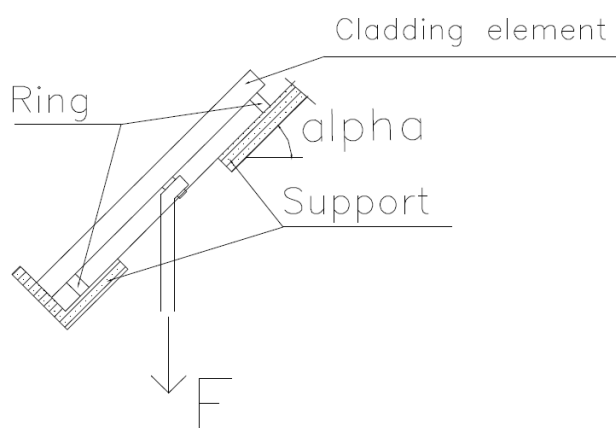

Figure J.1: Example of test of fixing.

The test specimen shall be loaded with a speed of 5 mm/min until failure.

The load F_s in kN at failure shall be measured and the type of failure (pull-out / cone failure or bending failure) shall be recorded.

J.6 Expression of results

The value of the load at bending failure in kN of each of the test specimens, F_c , shall be indicated.

The combined tension and shear resistance of fixing from cladding element is the mean value of the combined tension and shear resistance of the test specimens and shall be indicated as F_{cm} in kN.

The 5 % fractile value, $F_{cm,5\%}$, shall be calculated as follows.

$$F_{cm,5\%} = F_{cm} - k_n s$$

where:

$F_{cm,5\%}$ is the 5% fractile value of the combined tension and shear resistance

F_{cm} is the mean value the combined tension and shear strength of the test specimens in kN

k_n is the statistical factor (acceptance factor) in accordance with Annex O.

s is the standard deviation in kN

ANNEX K – IMPACT RESISTANCE TEST

K.1 General

The principle is to establish the impact resistance of the cladding kit considering hard body and soft body impacts. Besides, it is established the impact use categories to correspond to the degree of exposure to impacts in use.

The bodies to impact and the test equipment are indicated in EOTA technical report TR 001. The points of impact shall be selected taking into account the behaviour of the cladding element and the substrate, varying according to whether the impact point is or is not located in an area of greater rigidity (at less than 50 mm from the edge of cladding element).

Hard body impacts are:

- H1 and H2 (1 J and 3 J respectively), carried out with the steel ball weighing 0.5 kg and from a height of 0.20 m and 0.61 m respectively (at least in three locations).
- H3 (10 J), carried out with the steel ball weighing 1.0 kg and from a height of 1.02 m (at least in three locations).

Soft body impacts are:

- Small soft body S1 and S2 (10 J and 60 J respectively), carried out with the soft ball weighing 3.0 kg and from a height of 0.34 m and 2.04 m respectively (at least in three locations).
- Large soft body S3 and S4 (100 J and 400 J respectively), carried out with the spherical bag weighing 50.0 kg and from a height of 0.61 and 0.82 m respectively (at least in the centre point of a cladding element).

Note: National building regulations in some member states may have specific requirements. The manufacturer may consider other energy values for the hard and soft body impacts. Any change shall be indicated in the ETA.

At least, the mechanically weakest design shall be tested.

The size of the test specimen shall be chosen to carry out all the impacts indicated in table K.1.

The dimensions of any indentation shall be reported. Noted shall be made of any damage caused.

K.2 Test procedure

Test procedure can be carried out using one of following options:

When the impact resistance is chosen by the manufacturer or it is known, using the impact tests indicated in table K.1 for this impact resistance chosen or known.

When the impact resistance is not known, using the sequence for the impact tests, indicated in table K.2, with the aim of obtaining the maximum impact resistance.

Table K.1 - Hard and soft body impact tests.

External impacts and assessment						
			Category IV	Category III	Category II	Category I
Hard body impact	H1	<ul style="list-style-type: none"> Weight: 0,5 kg Impact: 1 J (height 0,20 m) No. impacts: 3 Position of impacts: three different locations 	No perforated ⁽²⁾ No collapse No other dangerous failure	---	---	---
	H2	<ul style="list-style-type: none"> Weight: 0,5 kg Impact: 3 J (height 0,61 m) No. impacts: 3 Position of impacts: three different locations 	---	No perforated ⁽²⁾ No collapse No other dangerous failure	No deterioration ⁽¹⁾	No deterioration ⁽¹⁾
	H3	<ul style="list-style-type: none"> Weight: 1 kg Impact: 10 J (height 1,02 m) No. impacts: 3 Position of impacts: three different locations 	---	---	No perforated ⁽²⁾ No collapse No other dangerous failure	No deterioration ⁽¹⁾
Soft body impact	S1	<ul style="list-style-type: none"> Weight: 3 kg Impact: 10 J (height 0,34 m) No. impacts: 3 Position of impacts: three different locations 	No deterioration ⁽¹⁾	No deterioration ⁽¹⁾	---	---
	S2	<ul style="list-style-type: none"> Weight: 3 kg Impact: 60 J (height 2,04 m) No. impacts: 3 Position of impacts: three different locations 	---	---	No deterioration ⁽¹⁾	No deterioration ⁽¹⁾
	S3	<ul style="list-style-type: none"> Weight: 50 kg Impact: 300 J (height 0,61 m) No. impacts: 1 Position of impacts: At least in the centre point of a cladding element 	---	---	No deterioration ⁽¹⁾	---
	S4	<ul style="list-style-type: none"> Weight: 50 kg Impact: 400 J (height 0,82 m) No. impacts: 1 Position of impacts: At least in the centre point of a cladding element 	---	---	---	No deterioration ⁽¹⁾
<p>⁽¹⁾ Superficial damage, indentation marks are allowed, is considered as showing "no deterioration" for all the impacts.</p> <p>⁽²⁾ The test result is assessed as being "perforated" if there is any perforation to be observed in the cladding element (to be also observed by the rear side) in at least 2 of 3 impacts. Indentation marks and permanent deformations without collapse or dangerous failure in the cladding element are allowed. Breakage or permanent deformations without collapse or dangerous failure in any element of the subframe are allowed.</p>						

The technical assessment body shall establish that the cladding product does not present sharp or cutting edges and its surfaces do not cause bodily injury, to the occupants or people nearby.

K.3 Impact test sequence

When the impact resistance is not known, it is possible to obtain the maximum impact resistance following the increasing sequence for the impact tests, indicated in the table K.2.

To start the sequence indicated in the table K.2, it is considered that the assembled system might have the maximum impact resistance (impact use category I). If it is necessary, the manufacturer can choose to start the sequence from other impact resistance.

Table K.2 - Impact test sequence.

Impact H2	In the case of no indentation marks appear, then carry out the hard body impact H3.
	In the case of indentation marks and permanent deformations without collapse or dangerous failure in the cladding element or breakage or permanent deformations without collapse or dangerous failure in an element/s of the subframe appear but without perforations, then carry out the soft body impact S1. If the S1 impact result is satisfactory, the assembled system should be classified as Category III.
	In the case of perforations, collapse or dangerous appear, then carry out the hard body impact H1 and after that, the soft body impact S1. If the H1 and S1 impact results are satisfactory, the assembled system should be classified as Category IV.
Impact H3	In the case of no indentation marks appear, then carry out the soft body impact S2.
	In the case of indentation marks and permanent deformations without collapse or dangerous failure in the cladding element or breakage or permanent deformations without collapse or dangerous failure in an element/s of the subframe appear but without perforations, then carry out the soft body impact S2.
	In the case of perforations, collapse or dangerous failure appear, then carry out the soft body impact S1. If the S1 impact result is satisfactory, the assembled system should be classified as Category III.
Impact S2	In the case of no indentation marks appear, and no indentation marks have appeared during the hard body impact H3, the TAB and the manufacturer may choose if carry out the soft body impact S4 directly (to obtain the Category I) or carry out the S3 impact (to secure the Category II) before the S4 impact.
	In the case of perforations, permanent deformations or breakage appear; carry out the soft body impact S1. If the S1 impact result is satisfactory, the assembled system should be classified as Category III or IV (taking into account the hard body impact results).
Impact S3	In the case of no indentation marks appear, and hard body impacts H2 and H3 have been satisfactory, the assembled system should be classified as Category II.
	In the case of perforations, permanent deformations or breakage appear; carry out the soft body impact S1. If the S1 impact result is satisfactory, the assembled system should be classified as Category III or IV (taking into account the hard body impact results).
Impact S4	In the case of no indentation marks appear, and hard body impacts H2 and H3 have been satisfactory, the assembled system should be classified as Category I.
	In the case of perforations, permanent deformations or breakage appear; and the soft body impact S3 has not been carried out previously, then carry out the soft body impact S3.
NOTE: In the case of the H1 or S1 impact results will not be satisfactory, the assembled system must not be classified.	

K.4 Definition of the impact use categories

The categories given in table K.3 correspond to the degrees of exposure in use. They do not include an allowance for acts of vandalism.

Table K.3 - Impact use categories.

Category	Use
I	A zone readily accessible at ground level to the public and vulnerable to hard body impacts but not subjected to abnormally rough use. (e.g.: Façade bases in buildings sited in public locations, such as squares, schoolyards or parks. Cleaning gondolas can be used on the façade).
II	A zone liable to impacts from thrown or kicked objects, but in public locations where the height of the kit will limit the size of the impact; or at lower levels where access to the building is primarily to those with some incentive to exercise care (e.g.: Façade bases in buildings not sited in public locations (e.g. squares, schoolyards, parks) or upper façade levels in buildings sited in public locations that occasionally can be hit by a thrown object (e.g. ball, stone, etc.). Cleaning gondolas can be used on the façade).
III	A zone not likely to be damaged by normal impacts caused by people or by thrown or kicked objects (e.g.: Upper façade levels in buildings (not including base) not sited in public locations, that occasionally can be hit by a thrown object (e.g. ball, stone, etc.). Cleaning gondolas cannot be used on the façade).
IV	A zone out of reach from ground level (e.g. High façade levels that cannot be hit by a thrown object. Cleaning gondolas cannot be used on the façade).

ANNEX L – PULSATING LOAD

L.1 Principle

After applying the pulsating load, the mechanical resistance of the cladding fixing shall be determined by measuring the tensile load at failure.

L.2 Apparatus

The apparatus shall be a testing machine, capable of producing load cycles like a sine curve at a frequency of 2 to 6 Hz.

L.3 Test specimen

At least the number of test specimens shall be 5.

L.4 Conditioning

Prior to testing the test specimens shall be stored at a temperature of $(23 \pm 5)^\circ\text{C}$ for at least 12 hours.

L.5 Procedure

The test shall be carried out at a temperature of $(23 \pm 5)^\circ\text{C}$. The tests shall be carried out on cladding element sections with cladding fixing without edge and spacing effects.

The cladding fixing shall be exposed to 10,000 load cycles at a frequency of 2 to 6 Hz. The upper load and the lower load shall be chosen accordingly. The following loads can be considered as appropriated:

- upper load $F_{\max} = 50\% \times F_{\text{tm},5\%}$;
- lower load $F_{\min} = 20\% \times F_{\text{tm},5\%}$

where $F_{\text{tm},5\%}$ is the characteristic value of the tensile load of the panel-fixing determined according to Annex H.

During each cycle the load shall vary like a sine curve between F_{\max} and F_{\min} . The displacement shall be measured during the first loading up to the upper load and either continuously or at least after 1, 10, 100, 1,000 and 10,000 load cycles.

After completion of the load cycles the fixing shall be unloaded, the displacement measured and a tension test performed as indicated in Annex H. The load F_{pt} in kN at failure shall be measured.

L.6 Expression of results

The value of the load at failure in kN of each of the test specimens, F_{pt} , shall be indicated.

The tensile load of the cladding fixing after applying the pulsating load is the mean value of the test specimens and shall be indicated as F_{ptm} in kN.

The 5 % fractile value, $F_{\text{ptm},5\%}$, shall be calculated as follows.

$$F_{\text{ptm},5\%} = F_{\text{ptm}} - k_n s$$

where:

$F_{\text{ptm},5\%}$ is the 5% fractile value of the tensile load of the cladding fixing after applying the pulsating load

F_{ptm} is the mean value the tensile load of the cladding fixing after applying the pulsating load of the test specimens in kN

k_n is the statistical factor (acceptance factor) in accordance with Annex O.

s is the standard deviation in kN

ANNEX M – RESISTANCE TO THERMAL SHOCK

M.0 Definitions

Ambient temperature: The ambient temperature at testing shall be (23 ± 5) °C.

Steady state temperature of the external surface of the panel: The temperature of the external surface of the panel is steady state if during at least 2 minutes the temperature at each temperature measuring point changes not more than 2°C.

Steady state temperature of the external surface of the panel after cooling (cold steady state temperature): The temperature of the external surface of the panel after cooling (T_{cold}) is at a steady state if the temperatures in the centre of the panel and in the centre of all edges of the panel are lower than the actual ambient temperature + 4°C.

Change of deflection: The change of deflection is defined as the deviation from the initial deflection and deflection after the last cycle, measured on the middle of the span.

Change of flatness: The change of flatness is defined as the deviation of the initial total panel flatness or local panel flatness and the total and local panel flatness after the last cycle.

Change of dimensions: The change of dimensions is defined as the deviation between the initial dimensions and the dimensions after the last cycle.

M.1 Principle

The test panel, mounted in a test rig, is exposed to a number of temperature cycles, the temperature loaded on one side (the side which in practice is exposed to the sunlight).

At periods of every cycle, visual observations relating to a change in characteristics (blistering, delamination or formation of cracks) are recorded and deflection is continuously measured on the non-exposed side.

The deflection and the flatness of the panel is measured at the highest temperature at the last cycle.

M.2 Apparatus

The test equipment comprises the next elements:

- Test rig. A substrate which is a steel frame work to support a panel in a plane that may vary from horizontal to vertical orientation, with the fixing points as to be used in practice. The orientation of the plane is to be decided by the manufacturer.
- Heating and cooling equipment. Equipment shall be provided to heat and cool the exposed panel surface of the test specimen.

For the heating, IR lamps of 375 Watts are used in a screen of lamps with a distance of approximately 400 mm between the lamps. The number of lamps is depending on the size of the test specimen. The heating temperature of the panel by the lamps is continuously controlled by connecting the lamps to the temperature sensors by means of an automatic on-off switch.

For the cooling, sprinklers are installed between the lamps, which have an output of tap water of 1.25 l/min.m². The temperature of the tap water is approximately +15°C.

- Measurement of temperature. The temperature shall be measured with a temperature sensor having an accuracy of ± 1 °C.
- Instruments capable of measuring dimensions, deflection and flatness.
 - A metal rule or tape graduated in millimetres and permitting a reading to 0.5 mm;
 - A dial gauge having an accuracy of at least 0.1 mm;

- A measuring device for continuously measuring the deflection and a means of recording;
- A rigid straight bar of respectively 100 mm and 500 mm;
- A steel wire;
- Two spacers with dimensions 100 mm × 25 mm × thickness mm. The upper and lower surface shall be parallel.

M.3 Test specimen

The test specimen is defined as follows:

- a non airtight substrate (test rig) such as wood or steel rigid frame;
- the assembled system must be fixed to the test rig;
- the dimensions of the test specimen depend on the size of external cladding element and the specified cladding fixings. The size of the test specimen shall be such that the length of the test specimen shall be the greatest possible length between two cladding fixing as described in the kit and the width shall be the greatest width as described in the kit.

The tolerances due to manufacturing and/or installation and deformations due to temperature and humidity variations have to be taken into account.

For each type of panel the solar absorption coefficient, σ_e , of the outer surface shall be determined by using the following formula

$$\sigma_e = 1.0 - \tau_e - \rho_e$$

where

σ_e is the solar absorption coefficient;

τ_e is the solar transmittance coefficient;

ρ_e is the solar reflectance coefficient.

The solar transmittance coefficient, τ_e , and the solar reflectance coefficient, ρ_e shall be determined in accordance with the procedures detailed in EN 410.

The number of test specimen shall be one.

M.4 Conditioning

Prior to testing the test specimen shall be stored at a temperature of $(23 \pm 5)^\circ\text{C}$ for at least 24 hours.

M.5 Cycling procedure

The cycling procedure will be as follows:

- starting temperature is the ambient temperature;
- heat the panel to a temperature T °C and keep the panel at that temperature for 4 hours;
- cool the panel freely to cold steady state, T_{cold} , and keep the panel at that temperature for 1 hour;
- 1st cycle:
 - heat the panel to a temperature T °C and keep the panel at that temperature for 0,5 hour;
 - cool the panel forcedly within 10 minutes to cold steady state, T_{cold} , and keep the panel at that temperature for 0,5 hour.

- 2nd to 10th cycle. Repeat the 1st cycle for another 9 cycles.

The high temperature T °C shall be:

- A temperature of (70 ± 3) °C if the solar absorption coefficient, σ_e , of the outer surface of the panel is lower than 0.7;
- A temperature of (80 ± 3) °C if the solar absorption coefficient, σ_e , of the outer surface of the panel is equal to or greater than 0.7.

M.6 Determination of the dimensions, flatness and deflection of the panel

M.6.1 Determination of the dimensions

The length, width and diagonals shall be measured with a metal rule or tape at the following positions:

- horizontally – upper, middle and lower edge;
- vertically – left, middle and right edge;
- diagonals – both diagonals of the panel.

The measured values are rounded up to nearest 0.5 mm.

M.6.2 Determination of the flatness

The total panel flatness, f_p , shall be determined by tightening the steel wire with the help of the two timber spacers over the diagonals of outer surface of the panel. The distance between the steel wire and the panel surface is measured.

The local panel flatness, f_c , shall be determined on the outer surface of the panel with the two rigid straight bars (100 mm and 500 mm) with the help of the two timber spacers. The distance between the straight bar and the panel surface shall be measured.

M.6.3 Determination of the deflection

The deflection shall be measured at the midpoint between the cladding fixings.

M.7 Procedure

M.7.1 Installing of the test specimen

Mount the test specimen in accordance with the manufacturers instructions on the test rig, such that the distance between outer surface of the panel and the screen of heating lamps is approximately 1 metre.

Measure the dimensions, the flatness and the deflection of the panel in accordance with M.6.

Install the temperature sensors on the outer surface of the panel on at least the following positions (see Figure M.1):

- center of the external surface;
- at 100 mm from the edge of the panel at the mid-point of each edge;
- each corner at 100 mm from each edge.

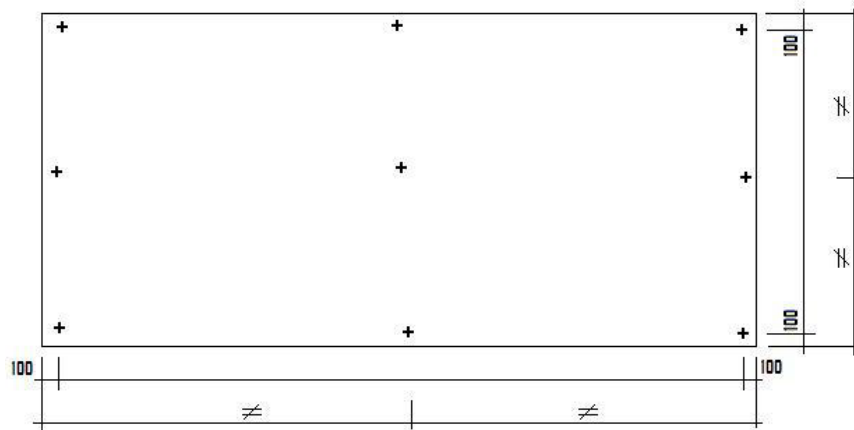

Figure M.1 – Positions of the temperature sensors

Install on the backside of the panel in the middle of the diagonals the measuring device for continuous determination of the deflection during the test.

M.7.2 Surface temperature

The surface temperature shall be the mean value of the temperatures measured at the all positions on the outer surface of the panel rounded up to the nearest degree Centigrade.

M.7.3 Execution of the test

Start the cycling procedure as detailed in M.5.

Observe visually during the cycling procedure if there is a cracking, blistering or delaminating and record this.

Record the deflection measurement on the backside of the panel.

Measure at the end of the 10th cycle the dimensions, the local and the total panel flatness and the deflection in accordance with M.6.

M.8 Expression of results

The change in deflection, the local and total panel flatness from the initial values to the values at the end of the tenth cycle shall be indicated.

ANNEX N – DETERMINATION OF THE DURABILITY OF THE ADHERENCE OF THE HONEYCOMB TO THE METALLIC SHEETS BY CHANGE IN SHEAR STRENGTH

N.1 Principle

The durability of the adherence of the honeycomb to the metallic sheets is assessed by measuring the change in shear strength of test specimens which are subjected to the following exposures:

- A cyclic temperature exposure of 50 cycles at a temperature between – 30°C and + 60°C;
- An exposure at a temperature of 100°C for 1500 h under dry conditions;
- An exposure in water at a temperature of 70°C for 1000 h.

N.2 Test specimens

N.2.1 Dimensions of the test specimens

The test specimens shall be an honeycomb adhered to two metallic sheets with the dimensions in accordance with the dimensions as stated in Annex G.

The test specimens shall be taken from the panel after the adhesive has been completely cured.

N.2.2 Number of test specimens

For the determination of the initial shear strength at least 5 test specimens shall be used.

For the determination the shear strength after each exposure at least 5 test specimens shall be used.

N.2.3 Conditioning of test specimens

Prior to the tensile test the test specimens shall be stored for at least 12 h at $(23 \pm 5)^\circ\text{C}$ and $(50 \pm 10)\%rh$.

N.3 Cyclic temperature exposure

N.3.1 Apparatus

Test chamber, where the temperature can be held at $-(30 \pm 2)^\circ\text{C}$ and $+(60 \pm 2)^\circ\text{C}$ and where the change in temperature from -30°C to $+60^\circ\text{C}$ and from $+60^\circ\text{C}$ to -30°C with a rate of $1.5^\circ\text{C}/\text{minute}$ can be achieved.

N.3.2 Exposure procedure

The exposure shall be carried out for 50 cycles between -30°C and $+60^\circ\text{C}$.

One cycle shall comprise of 5 hours at -30°C , change from -30°C to $+60^\circ\text{C}$ with a rate of $1.5^\circ\text{C}/\text{minute}$, 5 hours at $+60^\circ\text{C}$, change from $+60^\circ\text{C}$ to -30°C with a rate of $1.5^\circ\text{C}/\text{minute}$.

N.3.3 Determination of the shear strength

N.3.3.1 Determination of the initial shear strength

The initial shear strength of the test specimens shall be determined in accordance with 2.2.9.

The mean value of the initial shear strength shall be denoted as σ_{cs0} .

N.3.3.2 Determination of the shear strength after cyclic exposure

The shear strength of the test specimens after cyclic exposure shall be determined in accordance with 2.2.9.

The mean value of the shear strength after cyclic exposure shall be denoted as σ_{cs50} .

N.3.4 Expression of results

The change of shear strength in percentage after the cyclic temperature exposure shall be calculated as follows;

$$\Delta\sigma_{c.s} = \frac{\sigma_{c.s.0} - \sigma_{c.s.50}}{\sigma_{c.s.0}} \times 100 \%$$

N.4 Exposure at high temperature and dry conditions

N.4.1 Apparatus

Test chamber in which the temperature can be kept at $(100 \pm 2)^\circ\text{C}$ and dry conditions (relative humidity not greater than 15 %).

N.4.2 Exposure procedure

The exposure shall be carried out at 100°C and dry conditions for an exposure time of (1500 ± 12) hours.

N.4.3 Determination of the shear strength

N.4.3.1 Determination of the initial tensile strength

The initial shear strength of the test specimens shall be determined in accordance with 2.2.9.

The mean value of the initial shear strength shall be denoted as $\sigma_{100.s.0}$.

N.4.3.2 Determination of the shear strength after an exposure at 100°C and dry conditions

The shear strength of the test specimens after an exposure at 100°C and dry conditions for 1500 hours shall be determined in accordance with 2.2.9.

The mean value of the shear strength after an exposure at 100°C and dry conditions for 1500 hours shall be denoted as $\sigma_{100.s.1500}$.

N.4.4 Expression of results

The change of shear strength in percentage after an exposure at 100°C and dry conditions for 1500 hours shall be calculated as follows;

$$\Delta\sigma_{100.s} = \frac{\sigma_{100.s.0} - \sigma_{100.s.1500}}{\sigma_{100.s.0}} \times 100 \%$$

N.5 Exposure in water

N.5.1 Apparatus

A closed container with water in which the temperature can be kept at $(70 \pm 2)^\circ\text{C}$.

N.5.2 Exposure procedure

The exposure shall be carried out at 70°C for an exposure time of (1000 ± 12) hours. Keep the test specimens in water with adequate spacing between them.

N.5.3 Determination of the shear strength

N.5.3.1 Determination of the initial tensile strength

The initial shear strength of the test specimens shall be determined in accordance with 2.2.9.

The mean value of the initial shear strength shall be denoted as $\sigma_{70.s.0}$.

N.5.3.2 Determination of the shear strength after an exposure in water at 70°C

The shear strength of the test specimens after an exposure in water at a temperature of 70°C for 1000 hours shall be determined in accordance with 2.2.9.

The mean value of the shear strength after an exposure in water at 70 °C for 1000 h shall be denoted as $\sigma_{70\text{ s }1000}$.

N.5.4 Expression of results

The change of shear strength in percentage after an exposure in water at 70°C for 1000 hours shall be calculated as follows;

$$\Delta\sigma_{70\text{ s}} = \frac{\sigma_{70\text{ s }0} - \sigma_{70\text{ s }1000}}{\sigma_{70\text{ s }0}} \times 100 \%$$

ANNEX O – GENERAL TEST RESULTS STATISTICAL INTERPRETATION

The eccentricity of 5 % with 75 % confidence, k_n , is showed in Table O.1.

Number of pieces	3	4	5	6	7	8	10	20	30	∞
Variable k_n	3.37	2.63	2.33	2.18	2.10	2.00	1.92	1.76	1.73	1.64

Table O.1 – The variable k_n as a function of the number of test pieces (see EN 1990 Eurocode: Basis of structural design, Table D1, V_x , unknown)