



EUROPEAN ASSESSMENT DOCUMENT

EAD 050013-00-0301

December 2016

**SPHERICAL AND CYLINDRICAL
BEARING WITH SPECIAL SLIDING
MATERIAL MADE OF FILLED PTFE
WITH SOLID LUBRICANT AND
REINFORCING FIBRES**

The reference title and language for this EAD is English. The applicable rules of copyright refer to the document elaborated in and published by EOTA.

This European Assessment Document (EAD) has been developed taking into account up-to-date technical and scientific knowledge at the time of issue and is published in accordance with the relevant provisions of Regulation (EU) No 305/2011 as a basis for the preparation and issuing of European Technical Assessments (ETA).

Contents

1.	Scope of the EAD	4
1.1	Description of the construction product	4
1.2	Information on the intended use(s) of the construction product	6
1.2.1	Intended use(s).....	6
1.2.2	Working life/Durability.....	6
1.3	Specific terms used in this EAD (if necessary in addition to the definitions in CPR, Art 2)	7
2.	Essential characteristics and relevant assessment methods and criteria	8
2.1	Essential characteristics of the product	8
2.2	Methods and criteria for assessing the performance of the product in relation to essential characteristics of the product	9
2.2.1	Load bearing capacity	9
2.2.2	Rotation capability	9
2.2.3	Displacement capacity	9
2.2.4	Durability aspects	10
2.2.5	Load bearing capacity (of the sliding element).....	10
2.2.6	Coefficient of friction (of the sliding element)	11
2.2.7	Durability aspects (of the sliding element)	12
2.2.8	Material properties of the special sliding material	12
2.2.9	Compressive strength of the special sliding material	13
2.2.10	Load - deformation behaviour of the special sliding material.....	13
2.2.11	High temperature resistance of the special sliding material.....	14
2.2.12	Resistance of the special sliding material against chemical and environmental influences	14
3.	Assessment and verification of constancy of performance	15
3.1	System(s) of assessment and verification of constancy of performance to be applied	15
3.2	Tasks of the manufacturer	15
3.3	Tasks of the notified body	16
3.4	Special methods of control and testing used for the verification of constancy of performance	16
3.4.1	Material properties of the special sliding material	16
3.4.2	Sliding behaviour of the special sliding material	16
3.4.3	Physical and mechanical properties of PTFE resin.....	17
3.4.4	Mechanical and physical properties of the solid lubricant.....	17
3.4.5	Mechanical and physical properties of the reinforcing fibres	18
3.4.6	Geometrical properties of the special sliding material sheet.....	18
4.	Reference documents	19
Annex A – GEOMETRICAL CONDITIONS OF use of THE SPECIAL SLIDING MATERIAL MADE OF FILLED PTFE WITH SOLID LUBRICANT AND REINFORCING FIBRES		20
Annex B – TEST METHOD OF FRICTION COEFFICIENT OF THE SPECIAL SLIDING MATERIAL		22
Annex C – ASSESSMENT OF COMPRESSIVE STRENGTH AND LOAD-DEFORMATION BEHAVIOUR OF THE SPECIAL SLIDING MATERIAL		23
Annex D – ASSESSMENT OF SLIDING BEHAVIOR		25
Annex E – WORKING LIFE OF THE CONSTRUCTION PRODUCT		30

1. SCOPE OF THE EAD

1.1 Description of the construction product

The construction product is a spherical or cylindrical bearing, which permits rotation and displacement movements by a plane and a curved sliding surface between bearing plates of steel (see Figure 1 and Figure 2). The subject of this EAD is the complete bearing, including, if relevant, the necessary guides or restraints. As an alternative to Figure 1, the bearing may also be used upside down, i.e. with flat sliding surfaces lying below (meaningful, for example in the case of steel bridges).

The spherical and cylindrical bearings are designed according to EN 1337-7 and may be combined with sliding elements according to EN 1337-2 as shown in EN 1337-1. Instead of pure PTFE according to EN 1337-2 a special sliding material made of PTFE filled with a solid lubricant and reinforcing fibres, with melting temperature of at least 50 °C higher than the maximum operating temperature described below, suitable for high temperatures outside the scope of EN 1337-2 is used for the sliding surfaces of the bearing.

Sliding surfaces with a diameter of the circumscribing circle of special sliding material sheets less than 75 mm or greater than 3000 mm, or effective bearing temperatures greater than + 48°C, or + 90 °C if requested by the manufacturer, are outside the scope of this EAD. Effective bearing temperatures above + 48 °C are limited to short periods as due to climate temperature changes. If composite material in accordance with EN 1337-2 is used in guides, the maximum effective bearing temperature is limited to + 48 °C. Spherical and cylindrical bearings with an included angle $2\theta > 60^\circ$ and $2\theta > 75^\circ$ respectively are beyond the scope of this EAD (see clause 1 and Figure 6 of EN 1337-7).

For the types of the bearings covered by this EAD, the drawings given in EN 1337-7, clause 3.1.2 and clause 3.1.9 apply. The components are indicated as given in the Figures 1 and 2 in this EAD.

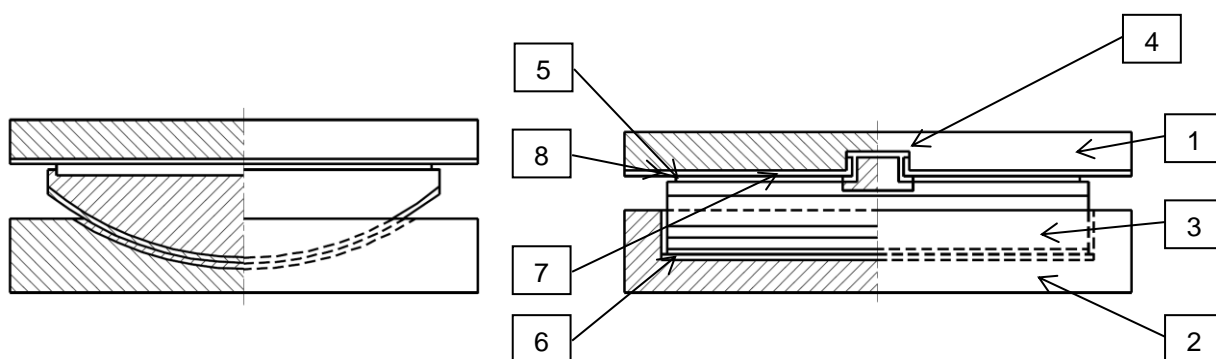

Figure 1: Cylindrical bearing

Legend for Figure 1:			
1	sliding plate	5	special sliding material
2	backing plate	6	special sliding material
3	rotational element	7	special sliding material or composite material strip
4	guide	8	austenitic steel sliding sheet

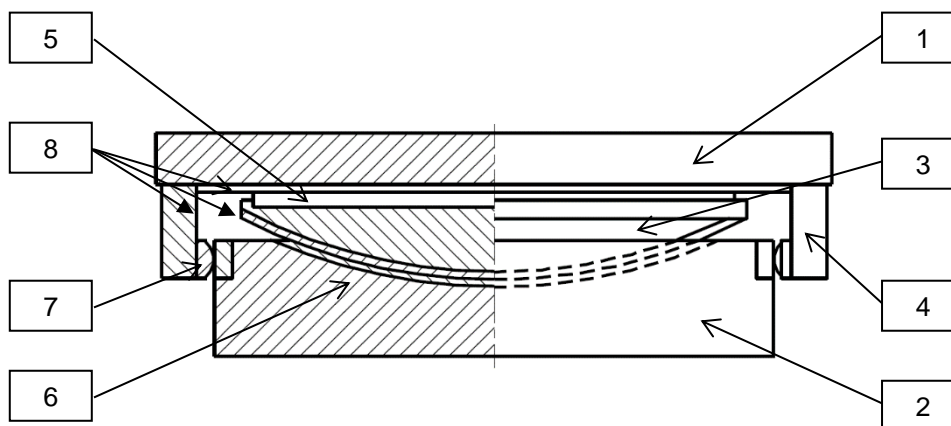

Figure 2: Spherical bearing

Legend for Figure 2:	
1	sliding plate
2	backing plate
3	rotational element
4	guide
5	special sliding material
6	special sliding material
7	special sliding material or composite material strip
8	austenitic steel sliding sheet

The sliding materials in the bearing are combined as shown in Table 1. Only one combination is used in a sliding surface. The sliding surface is lubricated in accordance with EN 1337-2, clause 7.4.

Table 1 Combination of materials for permanent applications as sliding surfaces for spherical and cylindrical bearings with special sliding material made of filled PTFE with solid lubricant and reinforcing fibres

Plane surface ¹⁾		Curved surface		Guides	
dimpled special sliding material	austenitic steel	dimpled special sliding material	austenitic steel	undimpled special sliding material ²⁾	austenitic steel
			hard chromium	CM1	
				CM2	
¹⁾ The sliding surface may be subdivided into two restrained parts above and below the rotation element permitting in total the design movement ²⁾ Instead of the undimpled sheets of special sliding material, only where self-alignment between the mating parts of the bearing is possible, composite materials in accordance with either clause 5.3.1 or 5.3.2 of EN 1337-2 can be used.					

The methods of assessment provided in this EAD are valid when the special sliding material in form of either dimpled or undimpled sheets is recessed into backing plates in accordance with the geometric conditions given in Annex A of the EAD.

The mating surfaces are made of either austenitic steel in accordance with clause 5.4 of EN 1337-2, or hard chromium plating in accordance with clause 5.5 of EN 1337-2.

The ferrous materials used for backing plates of the sliding surfaces are in accordance with EN 1337-2, clause 5.6.

Attachment of sliding materials is in accordance with clause 7.2 of EN 1337-2.

Where according to clause 6.4 of EN 1337-2 under predicted rotation about a transverse axis the differential deformation of the sheet made of special sliding material in guides across its smallest dimension for the un-factorized characteristic actions would exceed 0,2 mm, a rotation element shall be included in the backing plate. The material combination of this rotation element shall be in accordance with the

requirements of the mating surfaces of guides given in this EAD or pot to piston contact surfaces given in EN 1337-5.

The product is not fully covered by the following harmonised technical specification: *EN 1337-7:2004-04* for the following deviations:

- the use as sliding material in curved and flat sliding elements and in guides, instead of pure PTFE in accordance with EN 1337-2:2004-04, of a sliding material made of filled PTFE with solid lubricant and reinforcing fibres, suitable for high temperature outside the scope of EN 1337-2
- the maximum diameter of the circumscribing circle of special sliding material sheets used in flat and curved surfaces is 3000 mm in respect to 1500 mm.

Concerning product packaging, transport, storage, maintenance, replacement and repair it is the responsibility of the manufacturer to undertake the appropriate measures and to advise his clients on the transport, storage, maintenance, replacement and repair of the product as he considers necessary.

It is assumed that the product will be installed according to the manufacturer's instructions or (in absence of such instructions) according to the usual practice of the building professionals.

Relevant manufacturer's stipulations having influence on the performance of the product covered by this European Assessment Document shall be considered for the determination of the performance and detailed in the ETA.

1.2 Information on the intended use(s) of the construction product

1.2.1 Intended use(s)

The spherical or cylindrical bearings with special sliding material are intended to be used for the support of bridges or building works in accordance with the scope of EN 1337-1 where the requirements on the individual bearings are critical.

The spherical or cylindrical bearings with special sliding material made of filled PTFE are mainly used in concrete, steel and composite structures.

In case the spherical and cylindrical bearing according to this EAD is intended for use in non-rigid structures with relatively large and frequent displacements caused by working loads, next to superstructures that induce fast sliding displacements in bearings, e.g. in bridges for the high speed railways the sliding velocity of the type B phases in the long term friction test (see Table D.3 in this EAD) shall be at least 15 mm/s.

1.2.2 Working life/Durability

The assessment methods included or referred to in this EAD have been written based on the manufacturer's request to take into account a working life of the spherical and cylindrical bearings with special sliding material made of filled PTFE with solid lubricant and reinforcing fibres for the intended uses to be expressed in the European Technical Assessment in terms of years depending on the accumulated total slide path assessed according to clause 2.2.6 and related Annex D and Annex E of this EAD. The working life of the bearing is reduced to 10 years if in bearing's guides the composite materials according to EN 1337-2 are used instead of the special sliding material covered by this EAD. These provisions are based upon the current state of the art and the available knowledge and experience.

When assessing the product, the intended use as foreseen by the manufacturer shall be taken into account. The real working life may be, in normal use conditions, considerably longer without major degradation affecting the basic requirements for works¹.

The indications given as to the working life of the construction product cannot be interpreted as a guarantee neither given by the product manufacturer or his representative nor by EOTA when drafting this EAD nor

¹ The real working life of a product incorporated in a specific work depends on the environmental conditions to which that work is subject, as well as on the particular conditions of the design, execution, use and maintenance of that work. Therefore, it cannot be excluded that in certain cases the real working life of the product may also be shorter than referred to above.

by the Technical Assessment Body issuing an ETA based on this EAD, but are regarded only as a means for expressing the expected economically reasonable working life of the product.

1.3 Specific terms used in this EAD (if necessary in addition to the definitions in CPR, Art 2)

For the purposes of this EAD, the terms and definitions given in EN 1337-2 and EN 1337-7 apply.

2. ESSENTIAL CHARACTERISTICS AND RELEVANT ASSESSMENT METHODS AND CRITERIA

2.1 Essential characteristics of the product

Table 2 shows how the performance of spherical and cylindrical bearings with special sliding material made of filled PTFE with solid lubricant and reinforcing fibres is assessed in relation to the essential characteristics.

Table 2 Essential characteristics of the product and methods and criteria for assessing the performance of the product in relation to those essential characteristics

No	Essential characteristic	Assessment method	Type of expression of product performance
Basic Works Requirement 1: Mechanical resistance and stability			
1	Load bearing capacity	clause 2.2.1	level
2	Rotation capability	clause 2.2.2	level
3	Displacement capacity	clause 2.2.3	level
4	Durability aspects	clause 2.2.4	description
5	Load bearing capacity (of the sliding element)	clause 2.2.5	level
6	Coefficient of friction (of the sliding element)	clause 2.2.6	level
7	Durability aspects (of the sliding element)	clause 2.2.7	description

Table 3 shows how the performance of the special sliding material made of filled PTFE with solid lubricant and reinforcing fibres is assessed in relation to the essential characteristics.

Table 3 Essential characteristics of the special sliding material made of filled PTFE with solid lubricant and reinforcing fibres and methods and criteria for assessing the performance of the special sliding material in relation to those essential characteristics

No	Essential characteristic	Assessment method	Type of expression of product performance
Basic Works Requirement 1: Mechanical resistance and stability			
1	Material properties of special sliding material	clause 2.2.8	description
2	Compressive strength of special sliding material	clause 2.2.9	level
3	Load – deformation behaviour of special sliding material	clause 2.2.10	level

No	Essential characteristic	Assessment method	Type of expression of product performance
4	High temperature resistance of the special sliding material	clause 2.2.11	description
5	Resistance of the special sliding material against chemical and environmental influences	clause 2.2.12	description

2.2 Methods and criteria for assessing the performance of the product in relation to essential characteristics of the product

Characterisation of the spherical and cylindrical bearings with special sliding material made of filled PTFE with solid lubricant and reinforcing fibres to be assessed shall be done in accordance with the geometrical conditions of special sliding material given in Annex A of this EAD.

2.2.1 Load bearing capacity

The sliding surfaces of spherical and cylindrical bearings shall be assessed according to clauses 6.2.1 to 6.2.3 of EN 1337-7, adapted to the essential characteristics of the used special sliding material:

- when calculating the total eccentricity e_t of the axial force N_s , the frictional resistance of the sliding surfaces is determined based on the coefficients of friction of the special sliding material assessed in accordance with clause 2.2.6 of this EAD;
- the temperature-dependent characteristic compressive strength of the special sliding material is given in clause 2.2.9 of this EAD.

Backing plates with concave surfaces shall be assessed in accordance with clause 2.2.5 of this EAD taking into account dimensional limitations shown in Figure 7 of EN 1337-7.

In case free spherical bearings (see Figure 4 a) of EN 1337-7) are fixed by a steel restraining ring as shown in Figure 4 d) of EN 1337-7, the steel restraining ring shall be assessed based on the design rules for the pot wall of pot bearings given in clause 6 of EN 1337-5.

The load bearing capacity is stated in the ETA referring to the maximum diameter of the sheet of special sliding material covered by this EAD and stated in the ETA and to each of the temperatures assessed in accordance with clause 2.2.9 in this EAD.

2.2.2 Rotation capability

The possible material combinations of curved sliding surfaces are given in Table 1 of this EAD. The resistance to rotation is expressed by the coefficient of friction, assessed in accordance with clause 2.2.6 of this EAD.

The rotation capability shall be assessed by check of the geometrical conditions in accordance with clause 6.2.4 of EN 1337-7.

The rotation capability is stated in the European Technical Assessment by means of the maximum rotation angle.

2.2.3 Displacement capacity

The displacement capacity of the individual bearing, shall be assessed for the single, maximum displacement, under consideration of EN 1337-1, by check of the geometrical conditions in accordance with clause 6.5.1 of EN 1337-2.

The cumulated displacement capacity of the spherical and cylindrical bearings with special sliding material made shall be stated in the ETA by means of the cumulated slide path assessed in the long term friction test in accordance with Annex D in this EAD.

2.2.4 Durability aspects

The measures for the protection of the spherical and cylindrical bearings with special sliding materials from the effects of the environment and other external influences, which would reduce the working life, shall be assessed in accordance with clause 4 of EN 1337-9.

2.2.5 Load bearing capacity (of the sliding element)

The backing plates of the sliding surfaces shall be assessed in accordance with clause 6.9 of EN 1337-2, adapted to the essential characteristics of the used special sliding material.

For the assessment of the maximum deformation $\Delta w_1 + \Delta w_2$ of the backing plates (see Figure 9 of EN 1337-2), the formula given below apply for the values of the relevant material characteristics fulfilling the boundary conditions given in Table 4.

$$\Delta w_1 + \Delta w_2 \leq h_0 \left(0,45 - 1,708k \sqrt{\frac{h_0}{L}} \right) \quad (1a)$$

and

$$h_r[\text{mm}] = h_0 - \Delta w_1 - \Delta w_2 - \Delta h \geq 1,0 + \frac{L[\text{mm}]}{3000} \quad (1b)$$

In the above formula, the following notations have been used:

$\Delta w_1 + \Delta w_2$	is the maximum deformation of the backing plates;
L	is the diameter of the circumscribing circle of special sliding material sheet;
h_0	is the height of protrusion of the sheet of special sliding material in unloaded condition;
Δh	is the variation of the protrusion height, h_r is the protrusion after loading, and
k	is the pressure -dependent stiffness coefficient assessed according to Annex C in this EAD.

If not, an individual formula for the assessment of the maximum deformation $\Delta w_1 + \Delta w_2$ is to be developed. In such cases where the indications of Table 4 of this EAD are not met, the procedure of Annex II of the Regulation (EU) No 305/2011 applies.

Note 1: This approach should ensure that unacceptable assumptions for the use of a sliding material with different material characteristics than those meeting the boundary conditions in Table 4 are avoided.

Table 4 Boundary conditions for applicability of Equation (1)

Property ^(a)	Boundary condition
Protrusion after loading [mm]	$1 \text{ mm} \leq h_r \leq 0,66 h_0$ ^(b)
Stiffness coefficient, modulus of elasticity	Value k, E_{tp}
Ratio tensile strength/yield strength	< 2,5
Ratio elongation at break/yield deformation	> 10
<p>^(a) See Table 7, clause 2.2.10 in this EAD.</p> <p>^(b) h_0 is the height of the protrusion in the initial (unloaded) condition; h_r is the height of protrusion after 48 hours of constant load according to clause C.1 in this EAD, but before removing the applied load.</p>	

Note 2: The boundary conditions given in Table 4 are not to be considered as threshold values for the product covered by this EAD. They are boundary conditions for the possible application of the relevant formula (1a and 1b) stated above. The relevant material characteristics are given by means of levels. If they meet the conditions given in Table 4 the formula (1a and 1b) given above can be used.

2.2.6 Coefficient of friction (of the sliding element)

The friction coefficients reflecting the sliding behaviour of the special sliding material are assessed according to the tests given in Annex D of this EAD.

- A) Assessment of the friction coefficients for sliding elements combined with dimpled and lubricated sheets of special sliding material

After the assessment of the maximum cumulated slide path, the maximum coefficient of friction $\mu_{max,T}$ shall be assessed at - 10 °C and + 21 °C at the pressure levels of $1/3 f_k$, $1/6 f_k$ and $1/12 f_k$, where f_k is the characteristic compressive strength of the special sliding material at temperature $T \leq + 35$ °C given in clause 2.2.9 of this EAD, following test procedure A₁ of Table D.3.

The assessment at - 10 °C is related to assessment of the friction coefficients for sliding elements combined with dimpled and lubricated special sliding material sheets at low temperatures, whereas the minimum effective bearing temperature does not fall below - 35 °C.

The assessment at + 21 °C is related to assessment of the friction coefficients for sliding elements combined with dimpled and lubricated special sliding material sheets at moderate low temperatures, whereas the minimum effective bearing temperature does not fall below - 5 °C.

- B) Assessment of the friction coefficients for guides

After the assessment of the maximum cumulated slide path of the guides, equivalent to 20% of the cumulated slide path of the dimpled and lubricated sheets of special sliding material according to clause A) above, the maximum coefficient of friction $\mu_{max,T}$ shall be assessed at - 10 °C and + 21 °C at the pressure level of $1/3 f_k$ following test procedure A₁ of Table D.3.

The assessment at - 10 °C is related to assessment of the friction coefficients for guides at low temperatures, whereas the minimum effective bearing temperature does not fall below - 35 °C.

The assessment at + 21 °C is related to assessment of the friction coefficients for guides at moderate low temperatures, whereas the minimum effective bearing temperature does not fall below - 5 °C.

2.2.6.1 Sliding elements incorporating dimpled and lubricated sheets made of special sliding material

Based on the test results as addressed in the sub-clause A), the maximum friction coefficient μ_{max} for each temperature range stated above, expressed as a function of the average pressure σ_2 (MPa) applied to the sheet of special sliding material, shall be assessed by enveloping the experimental values assessed at the pressure levels of $1/12 f_k$, $1/6 f_k$ and $1/3 f_k$, and stated in the ETA.

If the coefficients of friction in any type A phase of the long-term friction test exceed the values at the end of the long-term friction test, the exceeding expressed by related percentage shall be considered for the assessment of the values of the friction coefficient μ_{max} for the different temperature ranges.

If the range of operating temperature shall be extended to T_{max} , with $+ 48$ °C $\leq T_{max} \leq + 90$ °C, the friction coefficient assessed in both phases A₁ of the high temperature programme test in accordance with Table D.4 of this EAD shall be stated separately in the European Technical Assessment for the extended operating temperature range, if they exceed the values measured in any type A₁ phase of the long-term friction test.

The friction coefficients assessed in a short term friction test (type A₁ procedure) on dimpled special sliding material sheets combined with lubricant previously exposed to $T_{max} + 10$ °C for 60 days shall be stated separately in the ETA for the extended operating temperature range, if they exceed the values measured in any type A₁ procedure of the long-term friction test.

2.2.6.2 Sliding elements for guides incorporating initially lubricated sheets made of special sliding material

Based on the test results as addressed in such clause B), the maximum friction coefficient μ_{max} assessed for each temperature range stated above, shall be stated in ETA.

The extension of the range of operating temperature up to a maximum of + 90 °C is justified by the additional test given in clause 2.2.9 and Annex D of this EAD.

2.2.7 Durability aspects (of the sliding element)

Clause 7.3 of EN 1337-2 applies.

2.2.8 Material properties of the special sliding material

Material properties of the special sliding material made of filled PTFE with solid lubricant and reinforcing fibres shall be assessed in accordance with the methods specified in the following sub clauses in accordance with Table 5.

The test specimens shall be prepared from fully finished sheet but without dimples.

The test specimens shall be tested at + 23 °C ± 2 °C.

For assessment of ageing effects of the special sliding material, at least five specimens of the material shall be subjected to accelerated ageing by exposure to T_{max}^2 for a duration of 168 hours. After that the material properties given in Table 5 shall be assessed.

The special sliding material is regarded as resistant to ageing in case of a non-essential deviation of the material properties of the aged specimens in comparison to the results of un-aged specimen. The performance is expressed in the ETA as a description.

Table 5 Material properties of the special sliding material

Property	Testing Standard	Result
Young modulus	EN ISO 527-1 and -3	level
Yield strength		level
Tensile strength		level
Elongation at break		level
Ball hardness	EN ISO 2039-1	level

2.2.8.1 Tensile properties

The test for Young modulus, yield strength, tensile strength and elongation at break shall be conducted on five specimens Type 5 (in accordance with Figure 2 of EN ISO 527-3). The thickness of the specimens shall be 2 mm ± 0,2 mm and the speed of testing shall be 50 mm/min for tensile strength and elongation at break, and 1 mm/min for Young modulus and yield strength.

2.2.8.2 Ball hardness

A total of 10 ball hardness tests shall be conducted in accordance with EN ISO 2039-1 using at least three specimens with a minimum of three tests for each specimen; the nominal thickness of the specimens shall be 8 mm.

² T_{max} is the maximum operating temperature required by the manufacturer, with + 48°C ≤ T_{max} ≤ + 90°C

2.2.9 Compressive strength of the special sliding material

The temperature-dependent characteristic compressive strength f_k of the special sliding material is defined as the maximum pressure on the sliding surface and shall be assessed according to the test described in Annex C, clause C.1 for the following temperatures:

$$T = T_0: \quad f_k(T_0), \text{ (with } T_0 \leq + 35 \text{ °C)}$$

$$T = 48 \text{ °C:} \quad f_k(T_{48})$$

If the range of operating temperature shall be extended up to T_{max} , with $+ 48 \text{ °C} \leq T_{max} \leq + 90 \text{ °C}$:

$$T = 60 \text{ °C:} \quad f_k(T_{60})$$

$$T = 70 \text{ °C:} \quad f_k(T_{70})$$

$$T = 80 \text{ °C:} \quad f_k(T_{80})$$

$$T = 90 \text{ °C:} \quad f_k(T_{90})$$

For a maximum effective bearing temperature in excess of $+ 35 \text{ °C}$ and up to $+ 48 \text{ °C}$, the characteristic compressive strength shall be assessed by linear interpolation of the values $f_k(T_0)$ and $f_k(T_{48})$.

For a maximum effective bearing temperature in excess of $+ 48 \text{ °C}$ and up to T_{max} , the characteristic compressive strength may be assessed by linear interpolation of the values above $f_k(T_{48})$.

The characteristic compressive strength shall be expressed in accordance with Table 6 and stated in the European Technical Assessment.

Table 6 Characteristic compressive strength of the special sliding material

Characteristic compressive strength [MPa]	Main sliding surface Permanent and variable loads	$f_k(T)$
	Guides Variable loads	
	Guides Permanent loads Effects of temperature, shrinkage and creep	$f_k(T)/3$

2.2.10 Load - deformation behaviour of the special sliding material

The load-deformation behaviour of the special sliding material, assessed in tests in accordance with Annex C and clause 2.2.8.1 of this EAD, shall be expressed in accordance with Table 7 and stated in ETA.

Table 7 Load - deformation behaviour of the special sliding material

Property	Test method	Result
Protrusion after loading [mm] ^(a)	clause 2.2.9 and Annex C of this EAD	level
Stiffness coefficient, modulus of elasticity	Annex C of this EAD	level
Ratio tensile strength/yield strength	clause 2.2.8.1 of this EAD	level
Ratio elongation at break/yield deformation	clause 2.2.8.1 of this EAD	level
^(a) "Protrusion after loading" is the height of protrusion after 48 hours of constant loading, meaning when having applied the maximum load but before removing.		

2.2.11 High temperature resistance of the special sliding material

The high temperature resistance of the special sliding material shall be expressed by means of the minimum melting temperature on three specimens in accordance with EN ISO 11357-3.

The special sliding material is considered as resistant to high temperature in case of a minimum melting temperature of at least 50° C above the maximum operating temperature T_{max} as requested by the manufacturer. The performance is expressed in the ETA as a description.

2.2.12 Resistance of the special sliding material against chemical and environmental influences

The resistance against chemical and environmental influences of the special sliding material shall be assessed following EN ISO 175 by separate exposure of test specimens described below for 60 days at ambient temperature to silicon grease according to EN 1337-2, distilled water and saturated aqueous solutions of:

- sodium chloride
- chromium chloride
- ferric chloride
- zinc chloride

Additionally the long term resistance against loss of material properties due to exposure to silicon grease according to EN 1337-2 shall be assessed by exposure of test specimens described below for 14 days at + 70 °C.

After the exposure the change of volume, loss of weight and the elongation at break according to clause 2.2.8.1 of this EAD shall be measured on five specimens each.

Test specimen: 50 mm x 25 mm x 1 mm for weight and volume measurements
 Type 5 according to Figure 2 of EN ISO 527-3 for elongation at break

The special sliding material is regarded as resistant to chemical and environmental influences in case of a maximum volume swelling of 3 %, a maximum loss of weight of 0,5 % and a non-essential alteration of the elongation at break after the above mentioned exposure of virgin sheets to each of the mentioned media and temperature. The performance is expressed in ETA as a description.

If the range of operating temperature shall be extended to T_{max} , with $+ 48\text{ °C} \leq T_{max} \leq + 90\text{ °C}$, specimens as described above shall be exposed to silicon grease according to EN 1337-2 for 90 days at T_{max} and for 21 days at $T_{max} + 10\text{ °C}$. After the exposure, the change of volume, loss of weight and the elongation at break according to clause 2.2.8.1 shall be measured on five specimens each.

The special sliding material is regarded as resistant to operating temperatures up to T_{max} in case of a maximum volume swelling of 3 %, a maximum loss of weight of 0,5 % and a non-essential alteration of the elongation at break after the above mentioned exposure of virgin sheets to silicon grease and temperatures of up to $T_{max} + 10\text{ °C}$. The performance is expressed in ETA as a description.

3. ASSESSMENT AND VERIFICATION OF CONSTANCY OF PERFORMANCE

3.1 System(s) of assessment and verification of constancy of performance to be applied

For the products covered by this EAD the applicable European legal act is: Decision 95/467/EC, as amended by Decision 2001/596/EC and Decision 2002/592/EC (EU). The system is: [1]

Note: Provisions for structural bearings in buildings and civil engineering works where requirements on individual bearings are critical. Critical in the sense that those requirements may, in case of failure of the bearing, put the works or parts thereof in states beyond those regarded as serviceability and ultimate limit states (cf. EN 1337-7, Table ZA.2).

3.2 Tasks of the manufacturer

The cornerstones of the actions to be undertaken by the manufacturer of the product in the procedure of assessment and verification of constancy of performance are given in EN 1337-7, whereas specific actions relevant to the special sliding material made of filled PTFE with solid lubricant and reinforcing fibres are laid down in Table 8.

Table 8 Control plan for the manufacturer; cornerstones

No	Subject/type of control	Test or control method	Criteria, if any	Minimum number of samples	Minimum frequency of control
Factory production control (FPC)					
1	Material properties of the special sliding material	3.4.1	a)	5 samples, except 3 samples for ball hardness	once each batch ≤ 500 kg for the first 10,000 kg of special sliding material, then 1,000 kg
2	Mass density of the special sliding material	EN ISO 1183-1	a)	3	
3	Melting temperature of the special sliding material	EN ISO 11357-3	a)	1	
4	Sliding behaviour of the special sliding material	3.4.2	a)	1	
5	Filler content of special sliding material	ISO 11358-1	a)	1	
6	Physical and mechanical properties of PTFE resin	3.4.3	a)	3.4.3	each batch
7	Physical and mechanical properties of solid lubricant	3.4.4	a)	3.4.4	each batch
8	Physical and mechanical properties of reinforcing fibres	3.4.5	a)	3.4.5	each batch
9	Geometrical properties of special sliding material sheet	3.4.6	3.4.6 Annex A	testing not required	each sheet
a) criteria to be established in the manufacturer's control plan prepared with consideration of the performance established in the ETA					

3.3 Tasks of the notified body

The cornerstones of the actions to be undertaken by the notified body in the procedure of assessment and verification of constancy of performance for spherical and cylindrical bearings with special sliding material made of filled PTFE with solid lubricant and reinforcing fibres are laid down in Table 9.

Table 9 Control plan for the notified body; cornerstones

No	Subject/type of control	Test or control method	Criteria, if any	Minimum number of samples	Minimum frequency of control
Initial inspection of the manufacturing plant and of factory production control					
1	According to EN 1337-7 Special sliding material: According to Table 8 in this EAD				when starting the production process or when starting a new production line
Continuous surveillance, assessment and evaluation of factory production control					
2	According to EN 1337-7 Special sliding material: According to Table 8 in this EAD For bearings with a diameter L of the special sliding material in the main sliding surface larger than 1500 mm: Single acceptance or at least 5 % for each lot of production				twice a year

3.4 Special methods of control and testing used for the verification of constancy of performance

3.4.1 Material properties of the special sliding material

Young modulus, yield strength, tensile strength, elongation at break and ball hardness of the special sliding material shall be assessed in accordance with the methods given in clauses 2.2.8.1 and 2.2.8.2 of this EAD.

The results of the testing shall comply with the levels laid down by the manufacturer in the control plan with consideration of the following criteria:

- Young modulus: range
- Yield strength: range
- Tensile strength: minimum value
- Elongation at break: minimum value
- Ball hardness: range

3.4.2 Sliding behaviour of the special sliding material

The sliding behaviour of the special sliding material shall be assessed in a short-term friction test in accordance with Annex B of this EAD.

The coefficients of friction in the short-term friction test shall not exceed the relevant levels laid down by the manufacturer in the control plan in accordance with Table B.

3.4.3 Physical and mechanical properties of PTFE resin

The raw material shall be pure polytetrafluoroethylene (PTFE) resin, free sintered and not regenerated. The physical and mechanical characteristics of the raw PTFE resin shall be assessed in accordance with Table 10.

The result of the testing shall comply with the relevant specifications laid down by the manufacturer in the control plan.

Table 10 Control plan for the raw PTFE resin

No	Subject/type of control	Test or control method	Criteria, if any	Minimum number of samples	Minimum frequency of control
Factory production control (FPC)					
1	Particle size (average d50)	ISO 13320	range	1	once each batch
2	Mass density	ISO 1183-1	range	3	
3	Tensile strength	ISO 527-1 and -3	minimum level	5	
4	Elongation at break	ISO 527-1 and -3	minimum level	5	
5	Purity	material inspection certificate	minimum level	not applicable	

3.4.4 Mechanical and physical properties of the solid lubricant

The mechanical and physical properties of the solid lubricant shall be assessed in accordance with Table 11.

The result of the testing shall comply with the relevant specifications laid down by the manufacturer in the control plan.

Table 11 Control plan for the solid lubricant

No	Subject/type of control	Test or control method	Criteria, if any	Minimum number of samples	Minimum frequency of control
Factory production control (FPC)					
1	Particle Size (average d50)	material certificate	range	not applicable	once each batch
2	Surface Area (BET)	material certificate	range	not applicable	
3	Purity	material certificate	minimum level	not applicable	

3.4.5 Mechanical and physical properties of the reinforcing fibres

The mechanical and physical properties of the reinforcing fibres shall be assessed in accordance with Table 12.

The result of the testing shall comply with the relevant specifications laid down by the manufacturer in the control plan.

Table 12 Control plan for reinforcing fibres

No	Subject/type of control	Test or control method	Criteria, if any	Minimum number of samples	Minimum frequency of control
Factory production control (FPC)					
1	Average fibre length	material inspection certificate	range	not applicable	once every 5 batches
2	Average fibre diameter	material inspection certificate	range		
3	Mass density	material inspection certificate	range		
4	Tensile strength	material inspection certificate	minimum level		
5	Tensile modulus	material inspection certificate	minimum level		
6	Elongation at break	material inspection certificate	minimum value		
7	Purity	material inspection certificate	minimum level		

3.4.6 Geometrical properties of the special sliding material sheet

The geometrical properties (thickness t_p and dimensions, shape and pattern of dimples) of the special sliding material sheets shall be assessed in accordance with Annex A, clause A.1 of this EAD.

The admissible tolerance on thickness t_p of single sheets or associated multiple sheets of special sliding material is +0,3/-0,0 mm for sheets with a diameter L less than 1200 mm and +0,4/-0,0 mm for larger sheets.

Compliance with the requirements shall be assessed by means of inspection certificates type 2.2 in accordance with EN 10204 from the supplier of moulded sheets.

4. REFERENCE DOCUMENTS

As far as no edition date is given in the list of standards thereafter, the standard in its current version at the time of issuing the European Technical Assessment, is of relevance.

CPR	Regulation (EU) No 305/2011 of the European Parliament and of the Council of 9 March 2011 laying down harmonised conditions for the marketing of construction products and repealing Council Directive 89/106/EEC
EN 1337-1	Structural bearings - Part 1: General design rules
EN 1337-2	Structural bearings - Part 2: Sliding elements
EN 1337-5	Structural bearings - Part 5: Pot bearings
EN 1337-7	Structural bearings - Part 7: Spherical and cylindrical PTFE bearings
EN 1337-9	Structural bearings – Part 9: Protection
EN 1990	Eurocode - Basis of structural design
EN 10204	Metallic products – Types of inspection documents
EN ISO 175	Plastics - Methods of tests for the determination of the effects of immersion in liquid chemicals
EN ISO 527-1	Plastics - Determination of tensile properties - Part 1: General principles
EN ISO 527-3	Plastics - Determination of tensile properties - Part 3: Test conditions for films and sheets
EN ISO 1183-1	Plastics - Methods for determining the density of non-cellular plastics - Part 1: Immersion method, liquid pycnometer and titration method
EN ISO 2039-1	Plastics- Determination of hardness - Part 1: Ball indentation method
EN ISO 11357-3	Plastics - Differential scanning calorimetry (DSC) - Part 3: Determination of temperature and enthalpy of melting and crystallization (ISO 11357-3:2011)
ISO 13320	Particle size analysis -- Laser diffraction methods

ANNEX A – GEOMETRICAL CONDITIONS OF USE OF THE SPECIAL SLIDING MATERIAL MADE OF FILLED PTFE WITH SOLID LUBRICANT AND REINFORCING FIBRES

The figures given in clause A.1 and Table A.1 of this Annex establish the geometrical conditions for sheets of the special sliding material for which this EAD applies (see also clause 1.1 in this EAD).

A.1 Recessed special sliding material sheets

The special sliding material sheets are recessed into a backing plate as shown in Figure A.1 below. The shoulders of the recess are sharp and square to restrict the flow of the sliding material. The radius at the root of the recess does not exceed 1 mm. Intermittent gap between the edge of the sheet of sliding material and the recess does not exceed the values given in Table 12 of EN 1337-2 at room temperature. For diameters L between 1500 and 3000 mm the gaps are limited to L [mm] / 1250.

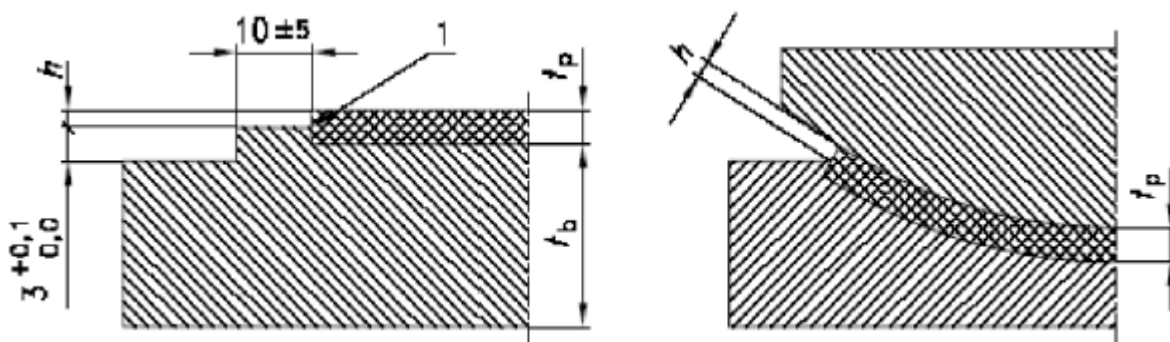

(See Figure 2 of EN 1337-2)

Figure A.1 - Details of special sliding material recess and relief

Table A.1 Geometrical conditions for thickness t_p and protrusion h of the special sliding material sheet in unloaded condition

	Flat and curved sliding surfaces	Guides ^(a)
Thickness t_p in mm	$2,65 \times h \leq t_p \leq 10,0$; with h in mm	$8,0 \leq t_p \leq 10,0$
Protrusion h in mm	$h = 2,50 + L/3000$	$h = 3,0 \pm 0,2$
L - diameter or diagonal of the projected area of the special sliding material sheet, in mm ^(a) the width of the guide strips is not less than 15 mm, and the modified shape factor calculated as in EN 1337-2, clause 6.2.1.3, is greater than 4.		

The tolerance on the protrusion h is $\pm 0,2$ mm for L less than or equal to 1200 mm and $\pm 0,3$ mm for L greater than 1200 mm. The protrusion h shall be assessed at marked measuring points, where the corrosion protection coating shall not exceed 300 μm . There shall be at least two measuring points, suitably located.

Special sliding material sheets used in the main flat or curved sliding surface are provided with a uniform pattern of dimples to retain the lubricant. The dimension, shape and arrangement of the dimples in the unloaded and unused condition, and the alignment in respect to the main direction of sliding, comply with Figure 1 of EN 1337-2.

A.2 Flat special sliding material sheets

Provisions for flat PTFE sheets given in sub-clause 6.2.1.1 of EN 1337-2 apply.

A.3 Curved special sliding material sheets

Provisions for curved PTFE sheets for cylindrical and spherical sliding surfaces given in sub clause 6.2.1.2 of EN 1337-2 apply, with the following adaptations:

- if circular special sliding material sheets for spherical sliding surfaces are subdivided in a disc and an annulus, the disc is not less than $\frac{2}{3} L$ for sheets with a diameter larger than 1500 mm;
- the absence of two symmetrical circular segments for not subdivided sheets is permissible, if the limitation for the included angle given in the scope and the proof of not separation of the sliding surface given in clause 6.8.2 of EN 1337-2 is fulfilled for both the main axes.

The curved special sliding material sheet may be attached to either the convex or the concave backing plate of the curved sliding surface.

A.4 Additional provisions

As an alternative to the geometrical rules given above and/or in clause 6.2.1 of EN 1337-2 flat and curved surfaces of spherical bearings made of special sliding material may consist of one centric circular sheet with diameter "a" and one or more concentric annuli with a constant width "b". The dimensions "a" and "b" are not smaller than 50 mm. The radial distance between the individual sheets is not less than 10 mm and not greater than twice the thickness of the backing plate, of the special sliding material or the mating material, whichever is less.

ANNEX B – TEST METHOD OF FRICTION COEFFICIENT OF THE SPECIAL SLIDING MATERIAL

This Annex describes the test method used within the factory production control as defined in Table 8, item 4, of this EAD and referred to the assessment given in Annex D in this EAD.

B.1 Method of assessment

To check the sliding behaviour of the special sliding material as element of the factory production control, a short-term friction test is performed consisting of 1 phase of 22 m sliding distance of type A₁ procedure according to Annex D, Table D.3 of the EAD on a specimens with dimpled and lubricated special sliding material sheet combined with austenitic steel.

B.2 Criteria

The coefficients of friction in short-term friction testing of phase A₁ shall not exceed the relevant levels laid down by the manufacturer in the control plan according to Table B.1 with consideration of performance established in the ETA.

Table B.1 The maximum coefficients of friction in short term test of dimpled and lubricated sheets made of special sliding material in combination with austenitic steel (pressure level: $f_d/3$)

Temperature	Total slide path			
	0 to 22 m			
	$\mu_{s,1}$	$\mu_{dyn,1}$	$\mu_{s,T}$	$\mu_{dyn,T}$
-35 °C	-	-	level	level
0 °C	level	level	-	-

NOTE $\mu_{s,1}$ and $\mu_{dyn,1}$ are the static and dynamic coefficients of friction at the first cycle, $\mu_{s,T}$ and $\mu_{dyn,T}$ the corresponding coefficients for the relevant temperatures at subsequent cycles

ANNEX C – ASSESSMENT OF COMPRESSIVE STRENGTH AND LOAD-DEFORMATION BEHAVIOUR OF THE SPECIAL SLIDING MATERIAL

C.1 Compressive strength

The compressive strength of the special sliding material at ULS condition is assessed by a long-term compression test. Under the characteristic compressive strength $f_k(T)$, defined in clause 2.2.9 of this EAD, the decrease of the protrusion shall end before 48 h of constant loading, and at pressures lower than f_k , no cracks shall occur in the sliding material.

The test specimens shall be prepared from fully finished sheet.

Test parameters:

Specimen: - dimpled special sliding material-sheet:

$L = 155 \text{ mm}$

$t_p =$ maximum value [mm] according to the range given in Table A.1 in this EAD

$t_p - h =$ minimum value [mm] according to the range given in Table A.1 in this EAD

- undimpled special sliding material-sheet for guides>

$L \times a = 200 \times 15 \text{ mm}$,

$t_p = 8 \text{ mm}$,

$t_p - h = 5 \text{ mm}$

- lubricant and dimples according to EN 1337-2

- austenitic steel according to EN 1337-2

- rigid backing plates according to EN 1337-2

Temperature: $T_0 \geq + 35 \text{ °C}$ and $T = + 48 \text{ °C} \pm 2 \text{ °C}$

If the range of operating temperature shall be extended to T_{max} , with $+ 48 \text{ °C} \leq T_{max} \leq + 90 \text{ °C}$:

additionally $T = + 60 \text{ °C}$, $T = + 70 \text{ °C}$, $T = + 80 \text{ °C}$, and $T = + 90 \text{ °C} \pm 2 \text{ °C}$

with $T \leq T_{max}$

Number of tests: 3 for each temperature level

Loading time: > 48 h

Pressure: $p = f_k(T)$ applied: to be expressed by means of a level and stated in the European Technical Assessment

The size of the protrusion h shall be continuously recorded.

The decrease of protrusion shall be defined as ended, if the change in height per hour in relation to the initial value of protrusion is less than 0,5 ‰.

C.2 Load deformation behaviour

The load deformation behaviour of the special sliding material at SLS condition is assessed by a long-term compression test.

Under a compressive stress $p = 0,25 f_k$ and $p = 0,5 f_k$ the decrease Δh of the protrusion after 48 h of constant loading shall be assessed.

The test specimens shall be prepared from fully finished sheet with dimples.

Test parameters:

- Specimen: - dimpled special sliding material-sheet:
 $L = 155$ mm,
 $t_p =$ value [mm] as assessed according to clause C.1 in this EAD,
 $t_p - h =$ value [mm] as assessed according to clause C.1 in this EAD
 - lubricant and dimples according to EN 1337-2
 - austenitic steel according to EN 1337-2
 - rigid backing plates according to EN 1337-2

Temperature: $+ 23$ °C ± 2 °C

Number of tests: minimum 3 for each pressure level

Loading time: > 48 h

Pressure: $p = 0,25 f_k (T_0)$ and $p = 0,5 f_k (T_0)$

The size of the protrusion h shall be continuously recorded.

The measured characteristic value Δh as difference between the initial value h_0 in unloaded condition and the final value h_r under load after 48 hours shall be statistically evaluated in accordance with EN 1990, Annex D "Design assisted by testing" and the following characteristics assessed:

- stiffness coefficient $k = \frac{\Delta h}{h_0} \sqrt{S} = \frac{\Delta h}{h_0} \sqrt{\frac{L}{4h_0}}$ as 95 % characteristic value
- notational elastic modulus $E_{tp} = p \frac{t_p}{\Delta h}$ as 50 % characteristic value.

ANNEX D – ASSESSMENT OF SLIDING BEHAVIOR

The principles of assessing the sliding behaviour of the sliding surfaces, the terms and definitions as well as the test equipment and specimens are shown in Annex D of EN 1337-2. To assess the sliding behaviour of special sliding material made of filled PTFE with solid lubricant and reinforcing fibres to be used in guides an additional long-term test for initially lubricated strips without dimples shall be carried out.

The test procedure shall be carried out under the following conditions:

- Specimen:
- mating surfaces, backing plates and lubricant according to EN 1337-2
 - for dimpled special sliding material sheets
 - $L = 75 \text{ mm}$
 - $t_p = \text{value [mm]}$ as assessed according to clause C.1 of this EAD
 - $t_p - h = \text{value [mm]}$ as assessed according to clause C.1 of this EAD
 - for guides (undimpled special sliding material sheets)
 - $L \times a = 200 \times 15 \text{ mm}$
 - $t_p = 8 \text{ mm}$
 - $t_p - h = 5 \text{ mm}$

Test parameters and test conditions for sliding elements combined with special sliding material are given in Table D.3 of this Annex.

The test specimen with dimpled and lubricated special sliding material shall be subjected to a long-term friction test, whereas the principles of the test phases are given in Table D.1 below for an example of 50.000 m total slide path.

The test specimen used in curved sliding surfaces only shall be subjected to a long-term friction test of 1/5 slide path in relation to the cumulated slide path of the main sliding surfaces; the principles of the test phases are given in Table D.2 of this Annex for an example of 10.000 m total slide path.

Table D.1 Long-term friction test programme for dimpled and lubricated flat surfaces

	Example for 50.000 m total slide path						
Phase Number	1	2	3	19	20	21
Type	A ₁	B	A ₁	A ₁	B	A ₁
Distance	22 m	≥ 1.000 m and ≤ 11.000 m	22 m	22 m	≥ 1.000 m and ≤ 11.000 m	22 m

If the range of operating temperature shall be extended up to a maximum temperature of T_{max} , with $+ 48 \text{ °C} \leq T_{max} \leq + 90 \text{ °C}$, a test specimen as given above with dimpled and lubricated special sliding material sheet shall be subjected to a high temperature programme test consisting of 3 phases in accordance with Table D.4 of this Annex.

The test specimen for guides shall be subjected to a long-term friction test, whereas the principles of the test phases are given in Table D.2 of this Annex for an example of 10.000 m total slide path.

The fitting for the test specimen for guides with initially lubricated special sliding material sheets shall correspond in principle to those of composite materials as shown in Figure D.3 of EN 1337-2.

Table D.2 - Long-term friction test programme for initially lubricated guides and for the main curved sliding surfaces

Example for 10.000 m total slide path					
Phase Number	1	2	3	4	5
Type	A ₁	B	A ₁	B	A ₁
Distance	22 m	≥ 1.000 m and ≤ 6.000 m	22 m	≥ 1.000 m and ≤ 6.000 m	22 m

Table D.3 Friction test conditions for the special sliding material in accordance with Figure D.1 of this Annex

Type A₁ (phase 1,3,5 ... Temperature-Programme-Test) according to Figure D.1			
Contact pressure of special sliding material	σ_p	$0,33 f_{k0}^{+3}$	MPa
Temperature	T	0/-10/-20/-35/+35/+21 (± 1)	°C
Temperature gradient		0,5 \pm 1,0	°C/min
Preload time	t_{pl}	1	h
Sliding distance	s	$10^{+0,5}_0$	mm
Dwell time at the end of the strokes	t_0	12 \pm 1	s
Number of cycles (two strokes)	N	1100	
Sliding speed (constant)	v	$0,4^{+0,1}_0$	mm/s
Dwell between phases	t_0	1	h
Type B (phase 2, 4, 6 ...) according to Figure D.1			
Contact pressure of special sliding material	σ_p	$0,33 f_{k0}^{+3}$	MPa
Temperature	T	21 \pm 1	°C
Temperature gradient		0,5 \pm 1,0	°C/min
Sliding distance ¹⁾	s	8 ^{+0,5}	mm
Number of cycles (two strokes)	N	62.500 (1 km) $\leq n \leq$ 3.125.000 (50 km)	
Sliding speed (constant)	v	$\geq 2 (\pm 0,1)^2$	mm/s
Type F (High-- Temperature - Programme - Test)			
Contact pressure of special sliding material	σ_p	0,33 $f_k(T_{max}) [+3;0]^3$	MPa
Temperature	T	+21/+ T_{max}^3 /+21 (± 1)	°C
Temperature gradient		0,5 \pm 1,0	°C/min
Preload time	t_{pl}	1	h
Sliding distance	s	$10^{+0,5}_0$	mm
Dwell time at the end of the strokes	t_0	12 \pm 1	s
Number of cycles (two strokes)	N	300/5500 ⁴⁾ /300	
Sliding speed (constant)	v	$0,4^{+0,1}_0$	mm/s
Dwell between phases	t_0	1	h
¹⁾ Depending on the characteristics of the testing equipment, the sliding distance s may be increased up to $s = 40$ mm, and the total number of cycles N arranged accordingly, in order to maintain the same total cumulated slide path of the phase. ²⁾ If the spherical or cylindrical bearing is intended for use in non-rigid structures with relatively large and frequent displacements caused by working loads, next for superstructures that induce fast sliding displacements in bearings, e.g. in bridges for the high speed railways (see Clause 1.2), the sliding speed in type B phases is 15 mm/s. ³⁾ Depending on the maximum operating temperature requested by the manufacturer ⁴⁾ Including heating and cooling phase			

Table D.4 High temperature friction test programme for dimpled and lubricated surfaces

166 m total slide path					
Phase Number	1	2			3
Type	A ₁	F			A ₁
T [°C]	0/-10/-20/-35/+35/+21	+21	+ T _{max} ^{1) 2)}	+21	0/-10/-20/-35/+35/+21
Distance	22 m	6 m	110 m ¹⁾	6 m	22 m
¹⁾ Including heating and cooling phase; ²⁾ Depending on the maximum operating temperature requested by the manufacturer					

Note: The high temperature programme test shall show the influence of high temperature during sliding movements on the change of friction behaviour.

The evaluation of 166 m according to Table D.4: 50 % of 11 phases (for the long term friction test according to Table D.1 for 50 km) of 22 m equal to rounded 122 m plus the initial and end phase of both 22 m gives 166 m.

The contact pressure in phase F of the friction test is $0,33 f_k (T_{max})$ due to the respectively reduced compressive strength of the special sliding material at high temperature.

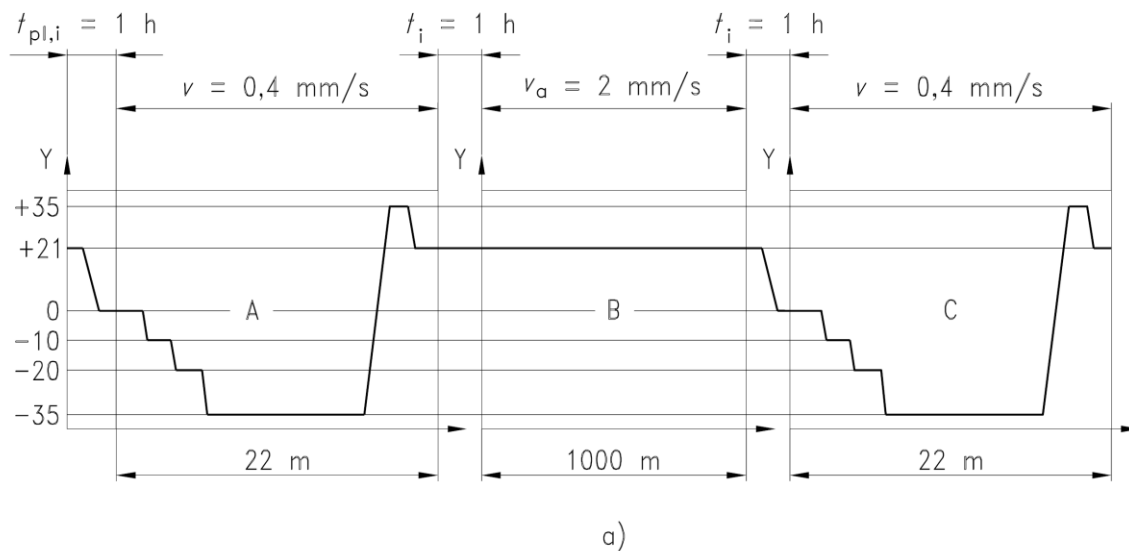

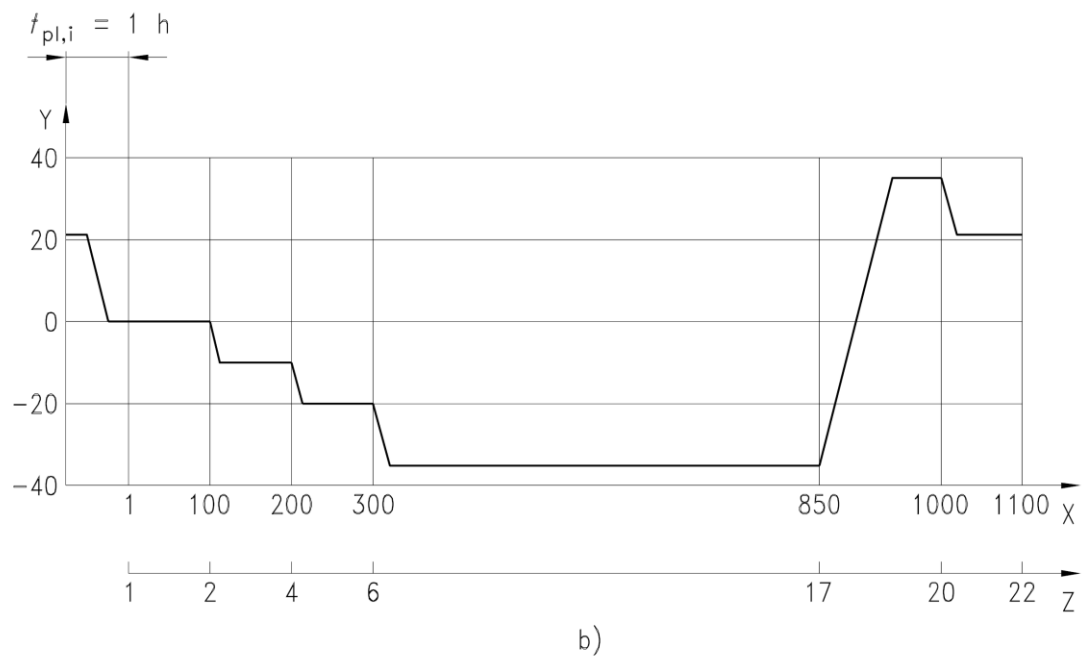

Figure D.1- Temperature profile of the long term sliding test (only first three phases shown)

Key:

- x Number of cycles n
- y Temperature T ($^{\circ}\text{C}$)
- a) Temperature -Programme-Test
- b) Total slide path

ANNEX E – WORKING LIFE OF THE CONSTRUCTION PRODUCT

The working life of structural bearings with sliding elements depends in particular on wear in the sliding surface by imposed movements combined with external loads. The durability of the sliding material is additionally affected by the sliding speed and the operating temperature.

Therefore, the singular case of intended use affects the expected working life.

Structural bearings with sliding elements made of PTFE according to EN 1337-2 are to be assumed suitable at least for the minimum working life of 10 years as specified in Table 2.1 of EN 1990 (design working life category 2).

Based on these assumptions the working life of spherical and cylindrical bearings with special sliding material made of filled PTFE with solid lubricant and reinforcing fibres as in clause 1.2.2 in this EAD shall be calculated as follows without consideration of the more severe test conditions:

$$WL = WL_{PTFE} \cdot \frac{S_{T,D1}}{S_{T,PTFE}}$$

Where

$S_{T,PTFE}$ cumulated slide path in accordance with Table D.2 of EN 1337-2 ($S_{T,PTFE} = 10.000$ m)

$S_{T,D1}$ cumulated slide path in accordance with Table D.1 of this EAD.

As example, for $S_{T,D1} = 50.000$ m

$$WL = WL_{PTFE} \cdot 10 \cdot \frac{50.000}{10.000} = 50 \text{ years}$$