

EUROPEAN ASSESSMENT DOCUMENT

EAD 040287-00-0404

June 2017

**KITS FOR EXTERNAL THERMAL
INSULATION COMPOSITE
SYSTEM (ETICS) WITH PANELS
AS THERMAL INSULATION
PRODUCT AND DISCONTINUOUS
CLADDINGS AS EXTERIOR SKIN**

The reference title and language for this EAD is English. The applicable rules of copyright refer to the document elaborated in and published by EOTA.

This European Assessment Document (EAD) has been developed taking into account up-to-date technical and scientific knowledge at the time of issue and is published in accordance with the relevant provisions of Regulation (EU) No 305/2011 as a basis for the preparation and issuing of European Technical Assessments (ETA).

Contents

| | | |
|----------|--------------------------------------------------------------------------------------------------------------------------------|-----------|
| 1 | Scope of the EAD | 5 |
| 1.1 | Description of the construction product | 5 |
| 1.2 | Information on the intended use(s) of the construction product | 6 |
| 1.2.1 | Intended use(s)..... | 6 |
| 1.2.2 | Working life/Durability..... | 6 |
| 1.3 | Specific terms used in this EAD (if necessary in addition to the definitions in CPR, Art 2)..... | 7 |
| 1.3.1 | Substrate | 7 |
| 1.3.2 | ETICS kit | 7 |
| 1.3.3 | Base coat..... | 7 |
| 1.3.4 | Base coat reinforcement | 7 |
| 1.3.5 | Insulation panel | 7 |
| 1.3.6 | Exterior skin..... | 7 |
| 1.3.7 | Cladding element | 7 |
| 1.3.8 | Cladding adhesive..... | 8 |
| 1.3.9 | Base adhesive | 8 |
| 1.3.10 | Mechanical fixings | 8 |
| 1.3.11 | Ancillary components | 8 |
| 2 | Essential characteristics and relevant assessment methods and criteria | 9 |
| 2.1 | Essential characteristics of the product | 9 |
| 2.2 | Methods and criteria for assessing the performance of the product in relation to essential characteristics of the product..... | 10 |
| 2.2.1 | Reaction to fire | 10 |
| 2.2.2 | Façade fire performance | 10 |
| 2.2.3 | Water absorption by capillarity | 10 |
| 2.2.4 | Water vapour permeability (resistance to water vapour diffusion) | 10 |
| 2.2.5 | Accelerated ageing behaviour..... | 11 |
| 2.2.6 | Wind load resistance | 12 |
| 2.2.7 | Impact resistance | 12 |
| 2.2.8 | Bond strength | 13 |
| 2.2.9 | Tensile strength of the thermal insulation panel..... | 13 |
| 2.2.10 | Shear strength and shear modulus of the thermal insulation panel..... | 13 |
| 2.2.11 | Dead load behaviour | 14 |
| 2.2.12 | Pull-through resistance..... | 14 |
| 2.2.13 | Pull-out resistance (foam block test) | 14 |
| 2.2.14 | Improvement of airborne sound insulation | 15 |
| 2.2.15 | Thermal conductivity and thermal resistance..... | 15 |
| 3 | Assessment and verification of constancy of performance | 16 |
| 3.1 | System(s) of assessment and verification of constancy of performance to be applied | 16 |
| 3.2 | Tasks of the manufacturer..... | 16 |
| 3.3 | Tasks of the notified body..... | 20 |
| 4 | Reference documents | 21 |
| | ANNEX A – REACTION TO FIRE | 24 |
| | ANNEX B – FAÇADE FIRE PERFORMANCE ASSESSMENT METHODS | 33 |
| | ANNEX C – WATER ABSORPTION BY CAPILLARITY TEST | 34 |

ANNEX D – WATER VAPOUR PERMEABILITY 36

ANNEX E – ACCELERATED AGEING PROCEDURES 37

ANNEX F – WIND LOAD RESISTANCE TEST 44

ANNEX G – IMPACT RESISTANCE TEST 47

ANNEX H – BOND STRENGTH TEST 51

ANNEX I – DEAD LOAD BEHAVIOUR TEST 53

ANNEX J – MECHANICALLY FIXED ETICS TESTS 56

ANNEX K – THERMAL RESISTANCE VALUES 60

ANNEX L – OTHER COMPONENTS TESTS 62

1 SCOPE OF THE EAD

1.1 Description of the construction product

This EAD applies to the kits¹ for ETICS applied in-situ² in which the exterior skin is composed by discontinuous claddings and the thermal insulation panel is fixed (either in the connection between the substrate and the insulation or between the insulation and the exterior skin) by means of one of the following methods:

- Bonded ETICS with supplementary mechanical fixings with 40% as minimum bonded surface area³,
- Mechanically fixed ETICS with supplementary adhesive.

The ETICS components are (sorted from internal layers to external layers):

1. Adhesive between the substrate wall and the thermal insulation panel.
2. Factory made panels made of cellular plastic (according to EN 13163, EN 13164, EN 13165, EN 13166) or mineral wool (according to EN 13162), with:
 - minimum tensile strength perpendicular to faces: 80 kPa;
 - minimum shear strength⁴: 20 kPa;
 - minimum shear modulus⁴: 1000 kPa.
3. Base coat with glass fibre mesh as reinforcement embedded into it.
4. Mechanical fixings (e.g. plastic anchors according to ETAG 014 used as EAD).
5. Adhesive between the discontinuous cladding and the base coat (e.g. adhesive for tiles according to EN 12004).
6. Discontinuous cladding element such as tiles, boards, panels or brick slips made of materials such as ceramic according to EN 14411; natural stone according to EN 1469 or agglomerated stone according to EN 15286.
7. Grout (e.g. for tiles according to EN 13888).
8. Ancillary components such as mastics, corner strips, joint covers, etc.

Note: the ETA should include the technical description of the ETICS components.

The adhesives, the base coat and the grout can include a range of binders from pure polymeric to pure cementitious. They can be available in the following forms:

- Powder (dry mortar) blended at the factory that requires only mixing with a quantity of water specified by the manufacturer;
- Powder requiring addition of extra binder;
- Paste requiring addition of cement;
- Ready to use paste, supplied in workable consistency.

1 Definition of “Kit” according to Art. 2 n° 2 of CPR. The components are installed on site, and thus, become a “system” when installed in the construction works.

2 The ETICS is not a product composed by prefabricated units fixed to the substrate by purely mechanical fixings according to ETAG 017.

3 Higher minimum bonded surface area may be required by national regulations. Bonded surface area calculated according to section H.5 of Annex H.

4 Higher minimum shear strength and shear modulus may be required by national regulations.

When the kit supplied by the manufacturer does not include all the components of the ETICS, the ETICS components which are not part of the kit and available on the market must be specified in the ETA. The assessment shall be done with the specified components.

The ETICS are designed to give the wall to which they are applied additional thermal insulation. The assembled systems should provide a minimal thermal resistance of 1,0 (m²·K)/W.

The product is not fully covered by ETAG 004 (February 2013). ETAG 004 does not consider external layers with discontinuous claddings. The product is not covered by the ETAG 017 (November 2015) because it is not a prefabricated unit (the ETICS components are installed in-situ) and it is not fixed to the substrate by purely mechanically fixings.

Concerning product packaging, transport, storage, maintenance, replacement and repair it is the responsibility of the manufacturer to undertake the appropriate measures and to advise his clients on the transport, storage, maintenance, replacement and repair of the product as he considers necessary.

It is assumed that the product will be installed according to the manufacturer's instructions or (in absence of such instructions) according to the usual practice of the building professionals.

Relevant manufacturer's stipulations having influence on the performance of the product covered by this European Assessment Document shall be considered for the determination of the performance and detailed in the ETA.

1.2 Information on the intended use(s) of the construction product

1.2.1 Intended use(s)

This EAD covers external thermal insulation composite systems (ETICS) on external vertical walls made of masonry (clay, concrete or stone), concrete (cast on site or as prefabricated panels) in new or existing buildings (retrofit).

1.2.2 Working life/Durability

The assessment methods included or referred to in this EAD have been written based on the manufacturer's request to take into account a working life of the kit for ETICS with discontinuous claddings as exterior skin for the intended use of 25 years when installed in the works (provided that the kit is subject to appropriate installation (see 1.1)). These provisions are based upon the current state of the art and the available knowledge and experience.

When assessing the product the intended use as foreseen by the manufacturer shall be taken into account. The real working life may be, in normal use conditions, considerably longer without major degradation affecting the basic requirements for works⁵.

The indications given as to the working life of the construction product cannot be interpreted as a guarantee neither given by the product manufacturer or his representative nor by EOTA when drafting this EAD nor by the Technical Assessment Body issuing an ETA based on this EAD, but are regarded only as a means for expressing the expected economically reasonable working life of the product.

⁵ The real working life of a product incorporated in a specific works depends on the environmental conditions to which that works is subject, as well as on the particular conditions of the design, execution, use and maintenance of that works. Therefore, it cannot be excluded that in certain cases the real working life of the product may also be shorter than referred to above.

1.3 Specific terms used in this EAD (if necessary in addition to the definitions in CPR, Art 2)

1.3.1 Substrate

The term "substrate" refers to a wall, which in itself already meets the necessary airtightness and mechanical strength requirements (resistance to static and dynamic loads).

It may be faced with mineral or organic renders or paints.

- Masonry walls: Walls constructed from units of burnt clay, concrete, calcium silicate, autoclaved aerated concrete or stone laid using mortar and/or adhesive.
- Concrete walls: Walls made of concrete either cast in situ or prefabricated at the factory.

1.3.2 ETICS kit

A set of at least two separate components placed on the market by the manufacturer as a kit used to execute the whole ETICS on site.

1.3.3 Base coat

Coat applied directly onto the insulation product; the reinforcement is embedded into it and provides most of the mechanical properties of the rendering.

1.3.4 Base coat reinforcement

Glass fibre mesh embedded in the base coat to improve its mechanical strength. Differentiation is made between:

- Standard mesh: embedded in the base coat all over the area and tied positively at joints, mostly by overlapping.
- Reinforced mesh: embedded in the base coat additionally to the standard mesh to improve the impact resistance, generally applied without overlapping.

1.3.5 Insulation panel

Factory made panels made of cellular plastic (according to EN 13163, EN 13164, EN 13165, EN 13166) or mineral wool (according to EN 13162) for which the main function is to impart the insulating properties to the wall to which it is applied.

1.3.6 Exterior skin

Set of components comprised of cladding element, cladding adhesive and grout that act as external covering which contributes to the protection against weathering and provide a decorative finish.

1.3.7 Cladding element

Tiles, boards, panels or brick slips made of materials such as ceramic, natural stone or agglomerated stone that form part of the exterior skin.

1.3.8 Cladding adhesive

Component used for bonding the cladding element to the reinforced base coat.

1.3.9 Base adhesive

Component used for bonding the insulation panel to the substrate.

1.3.10 Mechanical fixings

Profiles, anchors, pins or any special device used to secure the ETICS to the substrate.

1.3.11 Ancillary components

Any supplementary component or product used in the ETICS, e.g. to form joints (mastics, corner strips, etc.) or to achieve continuity (mastic, joint covers, etc.).

2 ESSENTIAL CHARACTERISTICS AND RELEVANT ASSESSMENT METHODS AND CRITERIA

2.1 Essential characteristics of the product

Table 1 shows how the performance of ETICS with discontinuous claddings as exterior skin is assessed in relation to the essential characteristics.

Table 1: Essential characteristics of the product and methods and criteria for assessing the performance of the product in relation to those essential characteristics.

| No | Essential characteristic | Assessment method | Type of expression of product performance |
|--------------------------------------------------------------------------------------------------------------|------------------------------------------------------------------|-------------------|-------------------------------------------|
| Basic Works Requirement 2: Safety in case of fire | | | |
| 1 | Reaction to fire | 2.2.1 | Class |
| 2 | Façade fire performance | 2.2.2 | Level / Description |
| Basic Works Requirement 3: Hygiene, health and the environment | | | |
| 3 | Water absorption by capillarity | 2.2.3 | Level |
| 4 | Water vapour permeability (resistance to water vapour diffusion) | 2.2.4 | Level |
| 5 | Accelerated ageing behaviour | 2.2.5 | Description |
| Basic Works Requirement 4: Safety and accessibility in use | | | |
| 6 | Wind load resistance (i) | 2.2.6 | Level |
| 7 | Impact resistance | 2.2.7 | Level |
| 8 | Bond strength | 2.2.8 | Level |
| 9 | Tensile strength of the thermal insulation panel | 2.2.9 | Level |
| 10 | Shear strength and shear modulus of the thermal insulation panel | 2.2.10 | Level |
| 11 | Dead load behaviour | 2.2.11 | Description |
| 12 | Pull-through resistance (i) (ii) | 2.2.12 | Level |
| 13 | Pull-out resistance (foam block test) (i) | 2.2.13 | Level |
| Basic Works Requirement 5: Protection against noise | | | |
| 14 | Improvement of airborne sound insulation | 2.2.14 | Level |
| Basic Works Requirement 6: Energy economy and heat retention | | | |
| 15 | Thermal conductivity and thermal resistance | 2.2.15 | Level |
| (i) This characteristic is only applicable to mechanically fixed ETICS with supplementary adhesive. | | | |
| (ii) This characteristic is only applicable when the anchors are fixed through the thermal insulation panel. | | | |

2.2 Methods and criteria for assessing the performance of the product in relation to essential characteristics of the product

2.2.1 Reaction to fire

The ETICS with discontinuous claddings as exterior skin shall be tested, using the test method(s) relevant for the corresponding reaction to fire class, in order to be classified according to Commission Delegated Regulation (EU) 2016/364 and EN 13501-1.

Criteria and associated mounting and fixing rules for the SBI test are given in Annex A.

2.2.2 Façade fire performance

If the manufacturer intends to declare the façade fire performance of the product, in absence of a European assessment approach, the ETA shall be issued taking into account the situation in Member States where the manufacturer intends his product to be made available on the market.

Information on such situation is included in Annex B.

2.2.3 Water absorption by capillarity

Water absorption by capillarity of the ETICS shall be tested according to the method indicated in Annex C.

Tests shall be carried out for:

- the whole ETICS, including the skin (cladding element, grout and cladding adhesive) and also;
- the ETICS without the skin (reinforced base coat as external layer).

At least the worst case (e.g. maximum water absorption of the ETICS components, maximum area of joints between the claddings, etc.) or the more representative case of the ETICS shall be tested.

Kit with each different type of thermal insulation material shall be tested.

Mean values of water absorption after 3 minutes, 1 hour and 24 hours of the ETICS (with and without the skin) shall be given.

If the mean value of the water absorption of the reinforced base coat after 1 hour is more than 1 kg/m², the mean value of the water absorption after 1 hour of the ETICS with the skin shall be less than 1 kg/m².

Besides, the water absorption of the cladding element, thermal insulation panel, grout and base coat should be given in the technical description of the ETICS.

Note: Requirements on the maximum water absorption of the individual components may exist in national regulations.

2.2.4 Water vapour permeability (resistance to water vapour diffusion)

The equivalent water vapour diffusion resistance of the whole ETICS shall be assessed by testing the whole ETICS according to EN ISO 12572.

Alternatively, the equivalent water vapour diffusion resistance of the whole ETICS can be assessed by calculation according to the method indicated in Annex D (using the water vapour permeability of each ETICS component).

Additionally, the water vapour diffusion resistance of the ETICS components (adhesives, thermal insulation panel, reinforced base coat, cladding adhesive, cladding element and grout) should be also given separately (see section D.1 of Annex D).

2.2.5 Accelerated ageing behaviour

2.2.5.1 Hygrothermal behaviour

Hygrothermal behaviour of the ETICS shall be assessed by means of bond strength tests (see section 2.2.8) of specimens taken from the ETICS submitted to the hygrothermal cycles indicated in section E.1 of Annex E.

At least the worst case (e.g. maximum water absorption of the ETICS components, maximum area of joints between the claddings, minimum cohesion and adherence of ETICS components, minimum thickness of ETICS components, etc.) or the more representative case of the ETICS shall be tested.

At the end of test programme, no water penetration shall be evident at the interface between the ETICS and the substrate.

If any of the following defects occur during or at the end of the hygrothermal cycles programme, it shall be recorded.

- deterioration such as cracking or delamination of the cladding elements that allows water penetration to the internal layers;
- deterioration or cracking of grout between the cladding elements;
- detachment of the skin;
- irreversible deformation.

Minimum value of bond strength tests (see section 2.2.8) after hygrothermal cycles shall be given.

The ratio between the bond strength mean value after hygrothermal cycles test and the mean value in the bond strength tests without ageing cycles shall be given.

2.2.5.2 Freeze-thaw behaviour

The freeze-thaw resistance test shall be done if the water absorption of the whole ETICS (see section 2.2.3) is greater or equal than 0,5 kg/m² after 24 hours.

Freeze-thaw behaviour of the ETICS shall be assessed by means of bond strength tests (see section 2.2.8) of specimens taken from the ETICS submitted to the freeze-thaw cycles indicated in section E.2 of Annex E.

At least the worst case (e.g. maximum water absorption of the ETICS components, maximum area of joints of cladding elements, minimum cohesion and adherence of ETICS components, minimum thickness of ETICS components, etc.) or the more representative case of the ETICS shall be tested.

If any of the following defects occur during or at the end of the freeze-thaw cycles programme, it shall be recorded.

- deterioration such as cracking or delamination of the cladding elements that allows water penetration to the internal layers;
- deterioration or cracking of grout between the cladding elements;
- detachment of the skin;
- irreversible deformation

Minimum value of bond strength tests (see section 2.2.8) after freeze-thaw cycles shall be given.

The ratio between the bond strength mean value after freeze-thaw cycles test and the mean value in the bond strength tests without ageing cycles shall be given.

Besides, the freeze-thaw resistance of the cladding element shall be given in the technical description of the ETICS.

2.2.5.3 Alternative test with combined hygrothermal and freeze-thaw cycles

Note: this alternative test method may be required in national regulations.

Alternatively, the accelerated ageing behaviour may be assessed by means of bond strength tests (see section 2.2.8) of specimens taken from the ETICS submitted to the combined hygrothermal cycles and freeze-thaw cycles indicated in section E.3 of Annex E.

At least the worst case (e.g. maximum water absorption of the ETICS components, maximum area of joints of cladding elements, minimum cohesion and adherence of ETICS components, minimum thickness of ETICS components, etc.) or the more representative case of the ETICS shall be tested.

If any of the following defects occur during or at the end of the combined hygrothermal and freeze-thaw cycles programme, they shall be recorded.

- deterioration such as cracking or delamination of the cladding elements that allows water penetration to the internal layers;
- deterioration or cracking of grout between the cladding elements;
- detachment of the skin;
- irreversible deformation

Minimum value of bond strength tests (see section 2.2.8) after combined hygrothermal and freeze-thaw cycles shall be given.

The ratio between the bond strength mean value after combined hygrothermal and freeze-thaw cycles test and the mean value in the bond strength tests without ageing cycles shall be given.

2.2.6 **Wind load resistance**

This characteristic is only applicable to mechanically fixed ETICS with supplementary adhesive.

Wind load resistance shall be tested according to the method indicated in Annex F.

At least, the mechanically weakest design (minimum density of fixings, thermal insulation panels and cladding elements with weaker resistances) shall be tested.

Maximum measured wind load resistance shall be given.

2.2.7 **Impact resistance**

Impact resistance shall be tested according to the method indicated in Annex G.

At least, the mechanically weakest design shall be tested.

The hard body and soft body impact resistances shall be given.

Additionally, the degree of exposure in use according to the categories defined in table G.2 of Annex G can be described.

2.2.8 Bond strength

Bond strength of the ETICS (in dry and other conditions) shall be tested according to the method indicated in Annex H.

Tests shall be carried out for the connections between the main layers of the ETICS and the conditions indicated in table H.1. of Annex H.

The tests shall be conducted only for the bonded connections of the ETICS (both between the substrate and the insulation and between the insulation and the exterior skin) without the mechanical fixings.

Each different combination of thermal insulation panel, base coat, adhesives and cladding element shall be tested.

Mean and minimum values of bond strength and the rate (in %) of rupture types (cohesive rupture and/or adhesive rupture) shall be given.

2.2.9 Tensile strength of the thermal insulation panel

The tensile strength perpendicular to faces of the thermal insulation panels shall be given according to the relevant harmonized standard (tested according to EN 1607). At least the worst case shall be tested (e.g. minimum density, maximum thickness, etc).

The test shall be carried out:

- on dry conditions (without any supplementary conditioning);
- after exposed to heat-moisture actions at (70 ± 2) °C and (95 ± 5) % RH in a climatic chamber for 7 days and followed by a drying period at (23 ± 2) °C and (50 ± 5) % RH until constant mass is achieved.
- after exposed to heat-moisture actions at (70 ± 2) °C and (95 ± 5) % RH in a climatic chamber for at least 28 days and followed by a drying period at (23 ± 2) °C and (50 ± 5) % RH until constant mass is achieved.

At least 5 specimens shall be tested.

Values shall be given according to the relevant hEN.

Note: When available, performances included in the DoP for the CE marking as individual component should be used as far as possible to avoid retesting or reassessment.

2.2.10 Shear strength and shear modulus of the thermal insulation panel

Shear strength and shear modulus of elasticity of the thermal insulation panel shall be determined according to EN 12090.

At least the worst case (e.g. maximum thickness, minimum tensile strength perpendicular to faces, etc.) or the more representative case of the insulation panel shall be tested.

The test shall be carried out:

- on dry conditions (without any supplementary conditioning);
- after exposed to heat-moisture actions at (70 ± 2) °C and (95 ± 5) % RH in a climatic chamber for 7 days and followed by a drying period at (23 ± 2) °C and (50 ± 5) % RH until constant mass is achieved.
- after exposed to heat-moisture actions at (70 ± 2) °C and (95 ± 5) % RH in a climatic chamber for at least 28 days and followed by a drying period at (23 ± 2) °C and (50 ± 5) % RH until constant mass is achieved.

Values of shear strength and shear modulus of elasticity of the thermal insulation panel shall be given according to the relevant hEN.

Note: When available, performances included in the DoP for the CE marking as individual component should be used as far as possible to avoid retesting or reassessment.

2.2.11 Dead load behaviour

Dead load behaviour shall be tested according to the method indicated in Annex I.

The test on bonded ETICS with supplementary mechanical fixing shall be conducted without the fixings. In the same way, the test on mechanically fixed ETICS with supplementary adhesive shall be conducted without the adhesive.

At least the worst case (e.g. maximum thickness and minimum tensile strength perpendicular to faces of the insulation panel, maximum thickness and weight of skin, maximum transverse deformation of the adhesives, minimum density of mechanical fixings, etc.) or the more representative case of the ETICS shall be tested.

Maximum dead load applied, maximum difference of displacement obtained and the deflection curves in function of the time shall be given.

2.2.12 Pull-through resistance

This characteristic is only applicable to mechanically fixed ETICS with supplementary adhesive when the anchors are fixed through the thermal insulation panel.

Pull-through resistance shall be tested according to the method indicated in Annex J.1.

Test samples are described in Annex J.1 taking into account if the anchors are placed at the body of the insulation panel or they are placed at the panel joint.

Each combination of insulation panel material and anchor shall be tested in dry conditions and, if appropriate, in wet conditions.

At least the worst case (e.g. minimum thickness and minimum tensile strength perpendicular to the faces of insulation panel, minimum plate diameter of anchor, minimum plate stiffness of anchor, minimum load resistance of anchor (see EOTA TR026)) shall be tested.

Mean and minimum value of pull-through resistance shall be given.

2.2.13 Pull-out resistance (foam block test)

This characteristic is only applicable to mechanically fixed ETICS with supplementary adhesive, in both cases, when the anchors are fixed through the reinforcement mesh embedded in the base coat and when the anchors are fixed through the thermal insulation panel.

Pull-out resistance shall be tested according to the method indicated in Annex J.2.

Test samples are described in Annex J.2 taking into account if the anchors are placed at the body of the insulation panel or they are placed at the panel joint.

Each combination of insulation panel, anchor, reinforcement mesh and base coat shall be tested in dry conditions and, if appropriate, in wet conditions.

At least the worst case (e.g. minimum thickness and minimum tensile strength perpendicular to the faces of insulation panel, minimum plate diameter of anchor, minimum plate stiffness of anchor, minimum load resistance of anchor (see EOTA TR026)) shall be tested.

Mean and minimum value of pull-out resistance shall be given.

2.2.14 Improvement of airborne sound insulation

Improvement of airborne sound insulation shall be tested according to EN ISO 10140-1 Annex G.

At least the worst or more representative ETICS composition shall be tested. For the configuration of the ETICS to be tested, the following rules shall be taken into account:

- insulation panels with higher dynamic stiffness provide worse performance;
- insulation panels with lower air flow resistance provide worse performance;
- a higher number of fixings provides worse performance;
- a higher base adhesive surface coverage provides worse performance;
- a higher mass of a skin layer provides better performance;
- a greater thickness of the insulation panel provides better performance;
- the performance for an insulation panel thickness between two tested ones can be linearly interpolated;
- anchors with plastic screws/nails provide better performance than with metal screws/nails.

The ratings of airborne sound insulation shall be undertaken according to EN ISO 717-1.

The weighed improvement ΔR_w , the sound reduction index R_w with and without the ETICS and the spectrum adaptation terms C and C_{tr} , shall be given.

2.2.15 Thermal conductivity and thermal resistance

Thermal resistance of the whole ETICS shall be calculated according to the method indicated in Annex K using the thermal resistance of the ETICS components.

Besides, the thermal conductivity or minimum thermal resistance of the ETICS components shall be given in the technical description of the ETICS.

3 ASSESSMENT AND VERIFICATION OF CONSTANCY OF PERFORMANCE

3.1 System(s) of assessment and verification of constancy of performance to be applied

For the products covered by this EAD the applicable European legal act is Decision 1997/556/EC.

The system is: **2+**

In addition, with regard to reaction to fire for products covered by this EAD the applicable European legal act is Decision 1997/556/EC.

The systems to be applied are: **1 or 2+**

3.2 Tasks of the manufacturer

The cornerstones of the actions to be undertaken by the manufacturer of the product in the procedure of assessment and verification of constancy of performance are laid down in Table 2a.

The actions to be undertaken by the manufacturer of the product for the different components of the kit are laid down in Table 2b to 2d if the components are produced by the manufacturer himself and Table 2e when the components are not produced by the manufacturer himself but by its supplier under the specifications of the manufacturer.

Table 2a: Control plan for the manufacturer; cornerstones.

| No | Subject/type of control | Test or control method (*) | Criteria, if any | Minimum number of specimens | Minimum frequency of control |
|---------------------------------------------------------------------------------------------------------------------------------------------------------------|----------------------------------------------------------------|-----------------------------------|--------------------------|-----------------------------------|-----------------------------------|
| Factory production control (FPC) | | | | | |
| 1 | <u>Components produced by the manufacturer himself:</u> | | | | |
| | ▪ Thermal insulation panels | Acc. to the relevant hEN standard | Acc. to the Control Plan | Acc. to the relevant hEN standard | Acc. to the relevant hEN standard |
| | ▪ Base coat, adhesives and grout | See table 2b | See table 2b | See table 2b | See table 2b |
| | ▪ Glass fibre reinforcement mesh | See table 2c | See table 2c | See table 2c | See table 2c |
| | ▪ Cladding elements | Acc. to the relevant hEN standard | Acc. to the Control Plan | Acc. to the relevant hEN standard | Acc. to the relevant hEN standard |
| | ▪ Anchors | See table 2d | See table 2d | See table 2d | See table 2d |
| 2 | <u>Components not produced by the manufacturer itself (**)</u> | See table 2e | See table 2e | See table 2e | See table 2e |
| (*) In all cases, the TAB and the manufacturer may agree to alternative tests or control methods or, where none exist, these parties may agree on the method. | | | | | |
| (**) Components produced by the supplier under the specifications of the manufacturer. | | | | | |

Table 2b: Control plan if the base coat, adhesives and/or grout are produced by the manufacturer itself; cornerstones.

| No | Subject/type of control | Test or control method (*) | Criteria, if any | Minimum number of specimens | Minimum frequency of control | | |
|------------------------------------------------------------------------------------------------------------------------------------------------------------------------------------------------------------------------------------------------------------------------------------------------------------------------------------------------------------------------------------------------------------------------------------------------------------------------|----------------------------------------------------------------|----------------------------------------------------------------------------------------|-------------------------------|--------------------------------------|----------------------------------------------|----------------------------|--|
| Factory production control (FPC) | | | | | | | |
| Base coat, adhesives and/or grout | | | | | | | |
| Incoming materials | | | | | | | |
| 1 | Receipt materials | Delivery ticket and/or label on the package Supplier certificates or supplier tests | Conformity with the order | --- | Each delivery | | |
| 2 | Particle size grading | Acc. to the prescription of the manufacturer | Acc. to the Control Plan | Acc. to the Control Plan | Acc. to the prescription of the manufacturer | | |
| 3 | Bulk density | | | | | | |
| Production process | | | | | | | |
| 4 | Mixing process | According to the Control Plan | According to the Control Plan | According to the Control Plan | According to the Control Plan | | |
| 5 | Packing | | | | | | |
| Finished component | | | | | | | |
| 6 | Density (1) | §L.1 | Acc. to the Control Plan | According to test or control methods | Acc. to the Control Plan (**) | | |
| 7 | Particle size grading (2) (3) | §L.2 | | | | | |
| 8 | Dry extract at 105°C (2) | §L.3 | | | | | |
| 9 | Ash content at 450°C (3) | §L.4.1 | | | | | |
| 10 | Modulus of elasticity, tensile strength and elongation (1) (5) | §L.5 | | | | | |
| 11 | Shrinkage (1) | §L.6 | | | | | |
| 12 | Slip (4) | EN 1308 | | | | | |
| 13 | Transverse deformation (4) | EN 12002 | | | | | |
| 14 | Bond strength (1) (5) | §2.2.8 | | | | At least once each 5 years | |
| 15 | Heat of combustion (1) | EN ISO 1716 | | | | At least once each 5 years | |
| (*) In all cases, the TAB and the manufacturer may agree to alternative tests or control methods or, where none exist, these parties may agree on the method. (**) The frequency is determined case by case depending on the variation in the volume produced and the production process control. (1) on hardened mortar (2) only for mortars delivered in paste (3) on powder mortar (4) only for adhesives (5) not applicable in the case of grout | | | | | | | |

Table 2c: Control plan when the glass fibre reinforcement mesh is produced by the manufacturer himself; cornerstones.

| No | Subject/type of control | | Test or control method (*) | Criteria, if any | Minimum number of specimens | Minimum frequency of control |
|---------------------------------------------------------------------------------------------------------------------------------------------------------------|-----------------------------------|----------------|----------------------------------------------------------------------------------------|---------------------------|--------------------------------------|-------------------------------|
| Factory production control (FPC) | | | | | | |
| Glass fibre reinforcement mesh | | | | | | |
| Incoming materials | | | | | | |
| 1 | Receipt materials | | Delivery ticket and/or label on the package Supplier certificates or supplier tests | Conformity with the order | --- | Each delivery |
| Finished component | | | | | | |
| 1 | Mass per unit area | | §L.7 | Acc. to the Control Plan | According to test or control methods | Acc. to the Control Plan (**) |
| 2 | Ash content at 625 °C | | §L.4.2 | | | |
| 3 | Mesh size and number of filaments | | §L.8 | | | |
| 4 | Tensile strength and elongation | without ageing | §L.9 | | | |
| | | with ageing | | | | |
| 5 | Alkali resistance | | Test or control acc. to the Control Plan | | | |
| 6 | Heat of combustion | | EN ISO 1716 | At least each 5 years | | |
| (*) In all cases, the TAB and the manufacturer may agree to alternative tests or control methods or, where none exist, these parties may agree on the method. | | | | | | |
| (**) The frequency is determined case by case depending on the variation in the volume produced and the production process control. | | | | | | |

Table 2d: Control plan when the anchors are produced by the manufacturer himself; cornerstones.

| No | Subject/type of control | | Test or control method (*) | Criteria, if any | Minimum number of specimens | Minimum frequency of control |
|---------------------------------------------------------------------------------------------------------------------------------------------------------------|----------------------------|--|------------------------------------------------------------------------------------|---------------------------|--------------------------------------|-------------------------------|
| Factory production control (FPC) | | | | | | |
| Anchors | | | | | | |
| Incoming materials | | | | | | |
| 1 | Receipt materials | | Delivery ticket or label on the package Supplier certificates or supplier tests | Conformity with the order | --- | Each delivery |
| Finished component | | | | | | |
| 1 | Geometry | | Test or control acc. to the Control Plan | Acc. to the Control Plan | According to test or control methods | Acc. to the Control Plan (**) |
| 2 | Mechanical characteristics | | Test or control acc. to the Control Plan | | | |
| (*) In all cases, the TAB and the manufacturer may agree to alternative tests or control methods or, where none exist, these parties may agree on the method. | | | | | | |
| (**) The frequency is determined case by case depending on the variation in the volume produced and the production process control. | | | | | | |

Table 2e: Control plan when the components are not produced by the manufacturer; cornerstones.

| No | Subject/type of control | Test or control method (**) | Criteria, if any | Minimum number of specimens | Minimum frequency of control |
|-------------------------------------------------------------------------------------------------------------------------------------------------------------------------------------------------------------------------------------------------------------------------------------------------------------------------------------------------------------------------------------------------|----------------------------------------------------------------------------|-----------------------------|---------------------------|-----------------------------|------------------------------|
| Factory production control (FPC) | | | | | |
| 1 | Components belonging to Case 1 (*) | (1) | Conformity with the order | Testing is not required | Each delivery |
| | | (2) | Acc. to the Control Plan | Testing is not required | Each delivery |
| 2 | Components belonging to Case 2 (*): | (1) | Conformity with the order | Testing is not required | Each delivery |
| | ▪ Characteristics declared in DoP for the specific use within the kit. | (2) | Acc. to the Control Plan | Testing is not required | Each delivery |
| | ▪ Characteristics not declared in DoP for the specific use within the kit. | (3) | Acc. to the Control Plan | Acc. to the Control Plan | Acc. to the Control Plan |
| 3 | Components belonging to Case 3 (*): | (1) | Conformity with the order | Testing is not required | Each delivery |
| | | (3) | Acc. to the Control Plan | Acc. to the Control Plan | Acc. to the Control Plan |
| <p>(1) Checking of delivery ticket and/or label on the package. (2) Checking of technical data sheet and DoP or, when relevant: supplier certificates or supplier tests or test or control acc. to tables 2a to 2e above. (3) Supplier certificates or supplier tests or Test or control acc. to tables 2a to 2e above.</p> | | | | | |
| <p>(*) Case 1: Component covered by a hEN or its own ETA for all characteristics needed for the specific use within the kit. Case 2: If the component is a product covered by a hEN or its own ETA which, however, does not include all characteristics needed for the specific use within the kit. Case 3: The component is a product not (yet) covered by a hEN or its own ETA.</p> | | | | | |
| <p>(**) In all cases, the TAB and the manufacturer may agree to alternative tests or control methods or, where none exist, these parties may agree on the method.</p> | | | | | |

3.3 Tasks of the notified body

The cornerstones of the actions to be undertaken by the notified body in the procedure of assessment and verification of constancy of performance for ETICS with discontinuous claddings as exterior skin are laid down in Table 3.

Table 3: Control plan for the notified body; cornerstones.

| No | Subject/type of control | Test or control method | Criteria, if any | Minimum number of specimens | Minimum frequency of control |
|-----------------------------------------------------------------------------------------|--------------------------------------------------------------------------------------------------------------------------------------------------------------------------------------------------------------------------------------------------------------------------------------------------------------------------------------------------------------------------------------------------------------------------------------------------------------|------------------------|------------------|-----------------------------|------------------------------|
| Initial inspection of the manufacturing plant and of factory production control | | | | | |
| 1 | The notified body shall verify the ability of the manufacturer for a continuous and orderly control of the product according to the Control Plan. In particular the following items shall be appropriately considered <ul style="list-style-type: none"> - personnel and equipment - the suitability of the factory production control established by the manufacturer - full implementation of the prescribed Control Plan | | | | --- |
| Continuous surveillance, assessment and evaluation of factory production control | | | | | |
| 2 | The notified body shall verify that <ul style="list-style-type: none"> - the manufacturing process of the kit components - the system of factory production control - the implementation of the prescribed Control Plan are maintained. | | | | Once per year |

4 REFERENCE DOCUMENTS

As far as no edition date is given in the list of standards thereafter, the standard in its current version at the time of issuing the European Technical Assessment, is of relevance.

| | |
|------------|---------------------------------------------------------------------------------------------------------------------------------------------------------------------------------------------------------------------|
| ETAG 004 | External Thermal Insulation Composite Systems with Rendering. |
| ETAG 014 | Plastic Anchors for ETICS. |
| ETAG 017 | Vêture Kits. |
| EOTA TR001 | Determination of impact resistance of panels and panels assemblies. |
| EOTA TR025 | Determination of point thermal transmittance of plastic anchors for the anchorage of external thermal insulation composite systems (ETICS). |
| EOTA TR026 | Evaluation of plate stiffness from plastic anchors for fixing of external thermal insulation composite systems with rendering (ETICS). |
| EN 1015-10 | Methods of test for mortar for masonry - Part 10: Determination of dry bulk density of hardened mortar. |
| EN 1015-18 | Methods of test for mortar for masonry - Part 18: Determination of water absorption coefficient due to capillary action of hardened mortar. |
| EN 1015-19 | Methods of test for mortar for masonry - Part 19: Determination of water vapour permeability of hardened rendering and plastering mortars. |
| EN 12002 | Adhesives for tiles - Determination of transverse deformation for cementitious adhesives and grouts. |
| EN 12004 | Adhesives for tiles - Requirements, evaluation of conformity, classification and designation. |
| EN 12086 | Thermal insulating products for building applications - Determination of water vapour transmission properties. |
| EN 12087 | Thermal insulating products for building applications - Determination of long term water absorption by immersion. |
| EN 12088 | Thermal insulating products for building applications - Determination of long term water absorption by diffusion. |
| EN 12089 | Thermal insulating products for building applications - Determination of bending behaviour. |
| EN 12090 | Thermal insulating products for building applications - Determination of shear behaviour. |
| EN 12371 | Natural stone test methods - Determination of frost resistance. |
| EN 12372 | Natural stone test methods - Determination of flexural strength under concentrated load. |
| EN 12664 | Thermal performance of building materials and products. Determination of thermal resistance by means of guarded hot plate and heat flow meter methods. Dry and moist products of medium and low thermal resistance. |
| EN 12667 | Thermal performance of building materials and products. Determination of thermal resistance by means of guarded hot plate and heat flow meter methods. Products of high and medium thermal resistance. |
| EN 12808-4 | Grouts for tiles - Part 4: Determination of shrinkage. |
| EN 12865 | Hygrothermal performance of building components and building elements - Determination of the resistance of external wall systems to driving rain under pulsating air pressure. |
| EN 12939 | Thermal performance of building materials and products - Determination of thermal resistance by means of guarded hot plate and heat flow meter methods - Thick products of high and medium thermal resistance. |

| | |
|-------------|-------------------------------------------------------------------------------------------------------------------------------------------------------------------------------------------------------------------|
| EN 1308 | Adhesives for tiles - Determination of slip. |
| EN 13161 | Natural stone test methods - Determination of flexural strength under constant moment. |
| EN 13162 | Thermal insulation products for buildings - Factory made mineral wool (MW) products – Specification. |
| EN 13163 | Thermal insulation products for buildings - Factory made expanded polystyrene (EPS) products – Specification. |
| EN 13164 | Thermal insulation products for buildings - Factory made extruded polystyrene foam (XPS) products – Specification. |
| EN 13165 | Thermal insulation products for buildings - Factory made rigid polyurethane foam (PU) products – Specification. |
| EN 13166 | Thermal insulation products for buildings - Factory made phenolic foam (PF) products – Specification. |
| EN 13238 | Reaction to fire tests for building products - Conditioning procedures and general rules for selection of substrates. |
| EN 13495 | Thermal insulation products for building applications - Determination of the pull-off resistance of external thermal insulation composite systems (ETICS) (foam block test). |
| EN 13496 | Thermal insulation products for building applications - Determination of the mechanical properties of glass fibre meshes as reinforcement for External Thermal Insulation Composite Systems with renders (ETICS). |
| EN 13501-1 | Fire classification of construction products and building elements - Part 1: Classification using data from reaction to fire tests. |
| EN 13823 | Reaction to fire tests for building products - Building products excluding floorings exposed to the thermal attack by a single burning item. |
| EN 13888 | Grout for tiles - Requirements, evaluation of conformity, classification and designation. |
| EN 14411 | Ceramic tiles - Definitions, classification, characteristics, evaluation of conformity and marking. |
| EN 14617-1 | Agglomerated stone - Test methods - Part 1: Determination of apparent density and water absorption. |
| EN 14617-11 | Agglomerated stone - Test methods - Part 11: Determination of linear thermal expansion coefficient. |
| EN 14617-2 | Agglomerated stone - Test methods - Part 2: Determination of flexural strength (bending). |
| EN 14617-4 | Agglomerated stone - Test methods - Part 4: Determination of the abrasion resistance. |
| EN 14617-5 | Agglomerated stone - Test methods - Part 5: Determination of freeze and thaw resistance. |
| EN 1469 | Natural stone products - Slabs for cladding – Requirements. |
| EN 15286 | Agglomerated stone - Slabs and tiles for wall finishes (internal and external). |
| EN 15824 | Specifications for external renders and internal plasters based on organic binders. |
| EN 1602 | Thermal insulating products for building applications - Determination of the apparent density. |
| EN 1603 | Thermal insulating products for building applications - Determination of dimensional stability under constant normal laboratory conditions (23°C/50% relative humidity). |
| EN 1604 | Thermal insulating products for building applications - Determination of dimensional stability under specified temperature and humidity conditions. |
| EN 1607 | Thermal insulating products for building applications - Determination of tensile strength perpendicular to faces. |

| | |
|-----------------|-------------------------------------------------------------------------------------------------------------------------------------------------------------------------------------------|
| EN 1609 | Thermal insulating products for building applications - Determination of short term water absorption by partial immersion. |
| EN 1745 | Masonry and masonry products - Methods for determining thermal properties. |
| EN 1934 | Thermal performance of buildings. Determination of thermal resistance by hot box method using heat flow meter. Masonry. |
| EN 318 | Wood based panels - Determination of dimensional changes associated with changes in relative humidity. |
| EN 480-8 | Admixtures for concrete, mortar and grout - Test methods - Part 8: Determination of the conventional dry material content. |
| EN 822 | Thermal insulating products for building applications - Determination of length and width. |
| EN 823 | Thermal insulating products for building applications - Determination of thickness. |
| EN 998-1 | Specification for mortar for masonry - Part 1: Rendering and plastering mortar. |
| EN ISO 10140-1 | Acoustics - Laboratory measurement of sound insulation of building elements - Part 1: Application rules for specific products. |
| EN ISO 10211 | Thermal bridges in building construction - Heat flows and surface temperatures - Detailed calculations. |
| EN ISO 10456 | Building materials and products - Hygrothermal properties - Tabulated design values and procedures for determining declared and design thermal values. |
| EN ISO 10545-10 | Ceramic tiles. Part 10: Determination of moisture expansion. |
| EN ISO 10545-12 | Ceramic tiles. Part 12: Determination of frost resistance. |
| EN ISO 10545-2 | Ceramic tiles. Part 2: Determination of dimensions and surface quality. |
| EN ISO 10545-3 | Ceramic tiles. Part 3: Determination of water absorption, apparent porosity, apparent relative density and bulk density. |
| EN ISO 10545-4 | Ceramic tiles - Part 4: Determination of modulus of rupture and breaking strength. |
| EN ISO 10545-8 | Ceramic tiles - Part 8: Determination of linear thermal expansion. |
| EN ISO 1182 | Reaction to fire tests for products - Non-combustibility test. |
| EN ISO 11925-2 | Reaction to fire tests - Ignitability of products subjected to direct impingement of flame - Part 2: Single-flame source test (ISO 11925-2). |
| EN ISO 12572 | Hygrothermal performance of building materials and products - Determination of water vapour transmission properties. |
| EN ISO 13788 | Hygrothermal performance of building components and building elements. Internal surface temperature to avoid critical surface humidity and interstitial condensation. Calculation method. |
| EN ISO 1716 | Reaction to fire tests for products - Determination of the gross heat of combustion (calorific value). |
| EN ISO 6946 | Building components and building elements - Thermal resistance and thermal transmittance - Calculation method. |
| EN ISO 717-1 | Acoustics - Rating of sound insulation in buildings and of building elements - Part 1: Airborne sound insulation. |
| DIN 66133 | Determination of pore volume distribution and specific surface area of solids by mercury intrusion. |

ANNEX A – REACTION TO FIRE

A.1 General

A.1.1 Principle

The determination of reaction to fire of the ETICS with discontinuous claddings is based on testing of “the worst case” - the most critical configuration in sense of reaction to fire. According to the rules described further in the text, the classification obtained on the most critical configuration of the ETICS with discontinuous claddings is valid for all configurations having better performance in sense of reaction to fire.

For the particular parts of the components for ETICS with discontinuous claddings, the following principles apply:

Each combination of different types of ETICS components shall be tested separately, in particular:

- Each different type and material of thermal insulation panel.
- Each different materials of the skin (cladding elements and grouts).
- Within a family of component material (cladding element, grout, base coat, reinforcement mesh, thermal insulation and adhesives) the component with the highest amount of organic content⁶ (if there are only differences in the amount of organic content but no difference in the organic component itself) or the highest PCS value (according to EN ISO 1716) of this organic component shall be tested.
- In addition, each component selected for testing according to the previous point shall have the lowest amount of flame retardants.

A.1.2 Physical properties influencing the reaction to fire behaviour

- Type of insulation panel (composition, thickness, density).
- Type of cladding element (composition, thickness, density).
- Type of base coat, reinforcement mesh, grout and adhesives (composition, thickness, mass per unit area).
- Type and nature of fixings.
- The organic content of the binder and of any organic additive; this can be checked by providing the formulation of the cladding element, base coat, grout and adhesive, by performing suitable characterization tests or by determining the glow loss or net calorific value.
- Type and amount of flame retardant.

Note: fire breaks are important for the behaviour of the whole facade cladding system and cannot be assessed on the basis of SBI-testing. The influence can only be observed during a large scale test. Therefore breaks are not included in the mounting and fixing rules for the SBI-test.

Although the rest of this annex applies the “worst case scenario” for deciding what to test, it is accepted that, where the manufacturer produces a range of ETICS with discontinuous claddings having different overall classifications, it may group these together into a number of different sub-groups (e.g. each sub-group corresponding to a different overall classification) with the ‘worst case scenario’ being identified for each sub-group.

⁶ The manufacturer is responsible for the information on organic content per unit area. If the information is not available, the PCS value shall be tested to decide about the worst case.

Components of an ETICS, where these require separate assessment (as opposed to being tested as part of the ETICS as a whole), which are classified A1 without testing according to Decision 96/603/EC (as amended) do not need to be tested.

A.2 Testing according to EN ISO 1182

This test method is relevant for classes A1 and A2.

Using this test method, only the substantial components of the ETICS need to be tested. 'Substantial components' are defined by thickness (≥ 1 mm) and/or mass per unit area (≥ 1 kg/m²).

In the following, the insulation panel, cladding element, base coat, reinforcement mesh, grout and adhesives are considered as 'Substantial components'.

For these components, the principles specified in section A.1 shall be applied.

A.2.1 Insulation panel

For ETICS expected to be classified as A1 or A2, it is anticipated that only insulation panels with reaction to fire class A1 or A2 will form the insulation layer. For testing the insulation panel reference shall be made to the relevant product standards or other relevant documents.

A.2.2 Cladding element

For ETICS expected to be classified as A1 or A2, it is anticipated that only cladding elements materials with reaction to fire class A1 or A2 will form the cladding element. For testing the cladding element reference shall be made to the relevant product standards.

A.2.3 Base coat, grout and adhesives

The reaction to fire behaviour of the base coat, grout and adhesives not falling under EC Decision 96/603/EC (as amended) shall be tested taking into account the principles indicated in section A.1.

The test results can be directly applied to all variants with the same base coat, grout and adhesive with a lower amount of organic components. When the subject of the directly applied result contains a flame retardant, it shall be of the same type and its content shall be at least that of the product tested.

Differences greater than tolerances ± 10 % concerning the density shall be considered by testing the lowest and the highest density.

A.3 Testing according to EN ISO 1716 (PCS-value)

This test method is relevant for classes A1 and A2.

This test method shall be performed to all components of the ETICS except for cases which are classified as A1 without testing.

Parameters relevant for this test method are: composition (when performing calculation of the PCS_s-value), density or mass per unit area and thickness. Mechanical fixings and ancillary materials which are not continuous but discrete components of ETICS do not need to be considered for testing and for the calculation of the PCS_s.

A.3.1 Insulation panel

For testing the insulation panel, reference shall be made to the relevant product standards or other related documents.

It is not realistic to require that each insulation panel of the same type of material is tested within the classification of an ETICS. If the insulation panels come from different manufacturers and/or are of different thickness, density and formulation from those used in the testing, these may be used subject to the requirements of class A1 and A2 still being fulfilled. It shall be proved by that the ETICS, together with the actual insulation panel used in end use application, still fulfils the requirements concerning the PCS-value of the whole product. For example, it is sufficient to determine the PCS-value of the mineral wool and if this is lower than the originally tested product then it is acceptable to use the alternative mineral wool instead of that used in the original test.

Note: information relating to alternative insulation panels of the same type of material to that originally tested may be evaluated on the basis of the supplier's evidence provided within the context of its CE marking.

A.3.2 Cladding element

For testing the cladding element, reference shall be made to the relevant product standards.

It is not realistic to require that each cladding element of the same material is tested within the classification of an ETICS. If the cladding element come from different manufacturers and/or are of different thickness, density and formulation from those used in the testing, these may be used subject to the requirements of class A1 and A2 still being fulfilled. It shall be proved by calculation that the ETICS, together with the actual cladding element used in end use application, still fulfils the requirements concerning the PCS-value of the whole product. For example, it is sufficient to determine the PCS-value of the ceramic tile and if this is lower than the originally tested product then it is acceptable to use the alternative ceramic tile instead of that used in the original test.

Note: information relating to alternative cladding element of the same material to that originally tested may be evaluated on the basis of the supplier's evidence provided within the context of its CE marking.

A.3.3 Base coat and grout

In general, when performing calculations of the unit area referred PCS_s-value (related to the surface) the variant that provides the highest PCS_s-value shall be considered.

The test shall be performed in accordance with the principles specified in section A.1 applied to each component.

It is not necessary to test a base coat or grout with different grain sizes if the organic content is the same as or lower than that of the tested component.

The test results can be directly applied to all variants with the same base coat and grout but with a lower amount of organic components. When the subject of the directly applied result contains a flame retardant, it shall be of the same type and its content shall be at least that of the product tested.

A.3.4 Adhesive

For the adhesives of the ETICS, each product with a different formulation shall be tested for reaction to fire behaviour by selecting the variant with the highest amount of organic components. The test results can be directly applied to all variants with the same composition but lower amount of organic components. For the case where the base coat is used as the adhesive, the rules according to section A.3.3 shall be applied.

A.3.5 Reinforcement

Each type of reinforcement shall be tested according to EN ISO 1716. For reinforcement that is randomly dispersed (e.g. fibres) in the render then it shall be tested as part of the render.

A.4 Testing according to EN 13823 (SBI-test)

This test method is relevant for classes A2, B, C and D (in some cases also for A1).

Mounting and fixing provisions for the SBI-test for ETICS with claddings are indicated in section A.4.1.

Parameters which are relevant for this test method:

- Type of cladding element (thickness, dimensions, density).
- Type of grout, base coat and adhesives (composition, thickness and mass per unit area).
- Type of insulation panel (thickness and density).
- Type of reinforcement mesh (composition, thickness and mass per unit area).
- Amount of organic content of each component.
- Amount of flame retardant of each component, if any.

In principle, it is desirable to find the test specimen configuration that gives the worst case concerning the reaction to fire test results. In the test procedure according to EN 13823, values for the rate of heat release, total heat release, lateral flame spread, rate of smoke release, total smoke release and burning droplets are determined. Due to the possible effects of the insulation panel, the following proposals are divided by considering separately the testing of ETICS with class A1 and A2 insulation panels and the testing of ETICS with class B, C, D and E insulation panels.

A.4.1 Mounting and fixing provisions for the SBI-test

In this test procedure the whole ETICS shall be tested. The ETICS is fixed to a substrate representing that on which the ETICS is fixed in the end use application (reference is made to EN 13238). The fixing shall be made using either the base adhesive or mechanical fixings used in the end use application. When base adhesives are used, the test result is valid also for mechanical fixings.

When a purely mechanical fixing with plastic anchors is used the test result is valid also for metallic anchors.

The maximum testable thickness of the test specimen, including a standard substrate according to EN 13238, is 200 mm. However, in practice, for many ETICS, the total overall thickness may be greater than 200 mm. In such cases, using a standard substrate, the thickness of the insulation panel shall be reduced to provide for the maximum specimen thickness of 200 mm. Results obtained on an ETICS at 200 mm thickness are accepted for greater thicknesses.

The test specimen consists of a corner construction which shall be representative of the construction in practice. All edges can be covered with the skin excluding the bottom edge and the top of the specimen. The floor of the test trolley beneath the test specimen can be covered by an aluminium foil (see figure A.1).

It is recommended to prepare the specimens at the lab and then put it onto the trolley (with the foil on), or the manufacturer builds the wall at the factory and carries it to the lab where it is put onto the trolley. After preparation of the test specimens they shall be conditioned according to EN 13238.

A.4.2 Insulation panel

For the testing of ETICS with insulation panels with reaction to fire class A1 or A2 the insulation panel with the highest thickness, the highest density (with a tolerance of $\pm 10\%$) and the highest organic content (related to the mass in dried condition) has to be used for preparing the test specimen. The reaction to fire classes A1 or A2 of the insulation panel shall be proven separately⁷.

For the testing of ETICS with insulation panels with reaction to fire class B, C, D or E, each type of insulation panel material (i.e. EPS, XPS, PUR, PF and also MW in some cases) shall be tested within the system.

⁷ In some Member States requirements might exist to demonstrate the behaviour of products with respect to continuous glowing combustion in the case of fire. The mandates for the product standards, therefore, are currently under revision. Additional national assessment e.g. on the basis of national procedures to demonstrate this behaviour might be required until a European harmonised procedure is available.

For each type of insulation panel material, the insulation panel with the highest thickness and the highest density (with a tolerance of $\pm 10\%$) shall be used for preparing the test specimen. The reaction to fire class B, C, D or E of the insulation panel shall be proven separately⁷.

Note: Reaction to fire of the insulation panel included in the DoP for the CE marking as individual component should be used as far as possible to avoid retesting or reassessment.

For testing ETICS which the insulation panels are mounted onto the substrate by using an adhesive specimens shall be tested:

- on the highest thickness of the insulation panel in cases where the base adhesive has an organic content equal to or less than 15% (related to the mass in dried condition and in end use application), and
- on the highest and the lowest thickness of the insulation panel in cases where the base adhesive has an organic content of more than 15% (related to the mass in dried condition and in end use application).

A.4.3 Skin (cladding element, grout and cladding adhesive)

By testing one skin (combination between cladding element, grout and cladding adhesive) representing a range of different skins, the following rules should be applied to discriminate the composition, which is able to represent a range of skins:

- The cladding element, grout and cladding adhesive, taking account of the permissible combination(s) allowed by the manufacturer, shall be determined in accordance with the principles specified in section A.1.
- The test specimen shall be prepared with the cladding element, grout and cladding adhesive with the highest organic content or PCSs-value per unit area.
- For cladding elements reaction to fire different to class A1 or A2, the cladding elements with lowest and highest thickness and density have to be tested.
- For cladding adhesives and grouts having an organic content less than or equal to 5% (related to the mass in dried condition as used in the end use application), only the lowest thickness needs to be used for preparing the test specimen.
- For cladding adhesives and grouts having an organic content higher than 5%, both the lowest and the highest thickness of the layer of the cladding adhesives and grouts shall be used for preparing the test specimens.

Regardless of the organic content, only the highest thickness of a cladding adhesives and grouts shall be tested on insulation material with class A1 or A2-s1,d0.

A.4.4 Base coat

By testing one specific base coat representing a range of different base coats, the following rules shall be applied to discriminate the composition, which is able to represent a range of base coats:

- The base coat to be used for preparing the specimen, taking account of the permissible combination(s) allowed by the manufacturer, shall be determined in accordance with the principles specified in section A.1.
- For a base coat having an organic content less than or equal to 5% (related to the mass in dried condition as used in the end use application), only the lowest thickness needs to be used for preparing the test specimen.
- For a base coat having an organic content higher than 5%, both the lowest and the highest thickness of the layer of the base coat shall be used for preparing the test specimens.

Regardless of the organic content, only the highest thickness of a base coat shall be tested on insulation material with class A1 or A2-s1,d0.

A.4.5 Base adhesive

The influence of the type of base adhesive having an organic content of equal to or less than 15% (related to the mass in dry condition) is assumed to be negligible. Only the amount of organic content is considered important. Therefore, a base adhesive with the highest amount of organic content should be used for preparing the test specimens applied at the maximum thickness.

The influence of base adhesives having an organic content of more than 15% cannot be assumed to be negligible. Therefore, each type of adhesive with a different composition shall be tested by selecting the variant with the highest organic content.

A.4.6 Reinforcement

The specimens shall be prepared with the reinforcement that is intended to be used in end use application. If different reinforcements are intended to be used, the reinforcement with the highest PCS_S-value per unit area shall be used for preparing the SBI specimen. At the long wing of the SBI specimens a vertical joint of the reinforcement shall be included at a distance of 200 mm away from the inner corner of the specimens by 100 mm overlapping of the two layers of the reinforcement (that means the joint begins at a distance of 150 mm and ends at a distance of 250 mm away from the inner corner). The test results from a system with an overlap of the reinforcement of 100 mm are valid for all joints with an overlapping of 100 mm or more.

A.4.7 Application of test results

The test result is valid for:

- insulation panels:
- of the same type,
- with lower density,
- with lower thickness or between those evaluated in the tests, provided that the worst result of the two thicknesses tested is used for intermediate thicknesses,
- with equal or less organic content,
- skin:
 - of the same material of cladding element, grout and cladding adhesive,
 - the range of cladding element between lowest and highest thickness / density, for cladding elements reaction to fire different to class A1 or A2,
 - components with equal or lower organic content,
 - components with equal or lower PCS_S-value per unit area,
 - components with equal or higher content of the same type of flame retardants.
- base coats:
- with equal or less organic content,
- with equal or greater content of the same type of flame retardants,
- with equal or greater thickness if the organic content is equal to or less than 5%,
- base coat having more than 5% organic content: with thickness between those evaluated, provided that the worst result of the two thicknesses tested is used for intermediate thicknesses
- base adhesives:

- with equal or less organic content and equal or less thickness if the organic content is equal to or less than 15%,

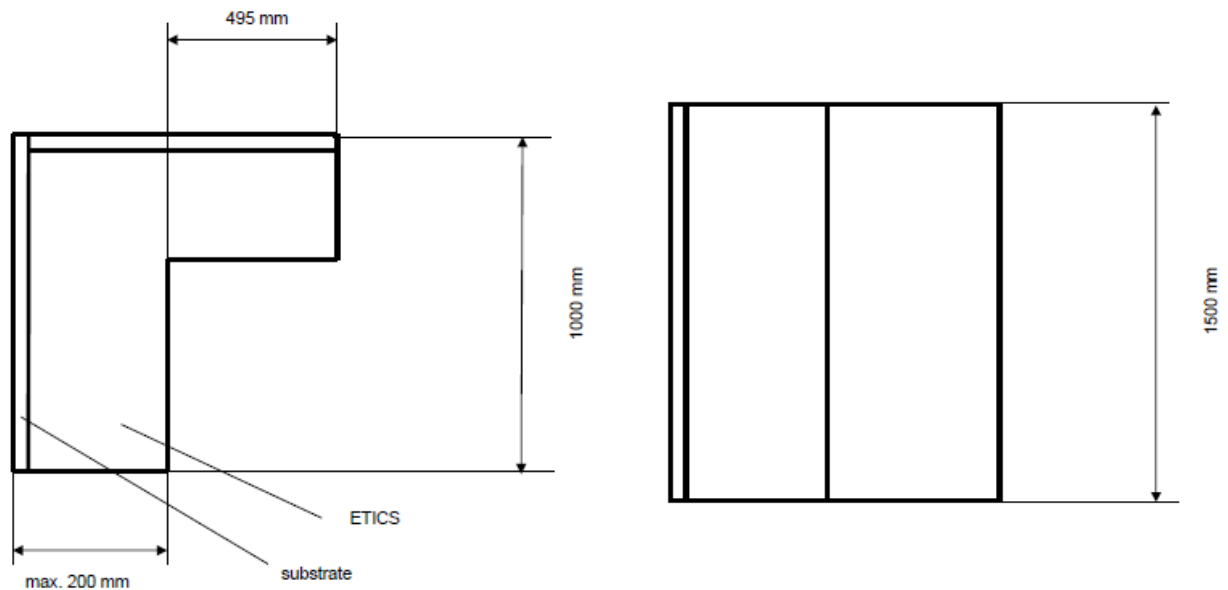

Figure A.1: Example of installation for ETICS.

Remark: This proposed test specimen arrangement is not in accordance with the standard due to the extended substrate of the small specimen wing, but is supposed to represent better the end use application.

A.5. Testing according to EN ISO 11925-2

This test method is relevant for the classes B, C, D and E.

In this test procedure, the ETICS is tested without using a substrate. The maximum thickness of the test specimen is 60 mm. In cases where the thickness of the ETICS is larger than 60 mm, the insulation panel may be reduced for the purposes of testing. The results from the testing of specimens at 60 mm are applicable to greater thicknesses.

Parameters which are relevant for this test method:

- Type of cladding element (thickness, dimensions and density).
- Type of grout, base coat and adhesives (composition, thickness and mass per unit area).
- Type of insulation panel (thickness and density).
- Type of reinforcement mesh (composition, thickness and mass per unit area).
- Amount of organic content of each component.
- Amount of flame retardant of each component, if any.

The specimens are prepared in such a way that the edges are not covered with the skin (cut edges). The tests are performed with surface flaming of the front side and possibly edge flaming of the test specimen turned by 90° according to the rules of standard EN ISO 11925-2.

A.5.1 Insulation panel

An insulation panel, representative in its characterisation (type, reaction to fire classification and density) for the end use application shall be used. The ETICS shall be evaluated incorporating the insulation panel at the highest possible thickness and the highest and the lowest possible densities.

For ETICS with insulation panes classified class E, the test results are valid only for the insulation panels as used in the test. Manufacturer has the possibility of using insulation panels from different manufacturers when the following additional tests are performed and conditions are fulfilled or the manufacturer provides the necessary evidence. For insulation panels made of polystyrene or PUR, it shall be proven separately that the product fulfils the requirements for reaction to fire class E under the following conditions. Polystyrene insulation has to be tested with the highest density and at a thickness of 10 mm for expanded polystyrene foam and at the minimum thickness produced for extruded polystyrene. The test result is valid for lower densities and higher thicknesses. PUR insulation shall be tested at the density intended for the end use and at the highest thickness. The test result is valid for PUR insulation with the same density and for lower thicknesses.

A.5.2 Skin

For testing one specific skin representing a range of different skins, the rules as mentioned in section A.4.3 apply.

A.5.3 Base coat

For testing one specific base coat representing a range of different base coats, the rules as mentioned in section A.4.4 apply.

A.5.4 Base adhesive

For adhesives (mortars) having an organic content of equal to or lower than 15% (related to the mass in dried condition) it can be assumed that they fulfil the requirements of the class B without testing according to EN ISO 11925-2. Therefore, no need exists to take into account such adhesives for preparing and testing specimens of ETICS according to this standard.

For adhesives having an organic content of more than 15% (related to the mass in dried condition) it is necessary to carry out a complete set of six additional tests on specimens turned at 90 degrees on their vertical axis with edge exposure of the adhesive layer. The specimens consist of the substrate, the adhesive and the insulation panel. The following rules shall be applied for preparing the specimens.

- Each type of adhesive with a different composition shall be used by selecting the variant with the highest amount of organic content and with the highest thickness,
- The insulation panel shall be used with the lowest thickness applied for the assessment,
- The substrate shall be the same as the one used for SBI testing of the ETICS as a whole.

A.5.4 Reinforcement

The specimen shall be prepared with the reinforcement intended to be used in end use application. If different reinforcements are intended to be used, the reinforcement with the highest PCS_S-value per unit area has to be tested.

A.5.5 Application of test results

The test result covers end use application arrangements with the same type of insulation panel (excluding insulation made of polystyrene or PUR) as used in the tests with thicknesses and densities as described in section A.5.1 and equal or lower organic content.

The test results from tests with insulation panels made of polystyrene or PUR classified class E are valid for ETICS with insulation panels as used in the test or for ETICS with any polystyrene and PUR insulation panels classified class E when the test evidence according to section A.5.1 was provided.

For the direct application of test results regarding skin, base coat, reinforcement and adhesives the same rules shall apply as given in section A.4.7.

ANNEX B – FAÇADE FIRE PERFORMANCE ASSESSMENT METHODS

| Country | Assessment method |
|---------------------------|--------------------------------------------------------------------------------------------------------------------------------------------------------------------------------------------------------------------------------------------------------------------------------|
| Austria | ÖNORM B 3800-5 |
| Czech Republic | ČSN ISO 13785-1 |
| Denmark, Sweden, Norway | SP Fire 105 |
| Finland | <ul style="list-style-type: none"> • Tekniikka opastaa 16 (Engineering guidance 16), • ”Kerrostalojen lisälämmöneristeen paloturvallisuus korjausrakentamisessa” (Fire safety of extra thermal insulation in reconstruction), 2001, published by SPEK. |
| France | LEPIR 2 |
| Germany | <ul style="list-style-type: none"> • DIN 4102-20 Complementary reaction-to-fire test for claddings of exterior walls, • Technical regulation A 2.2.1.5 |
| Hungary | MSZ 14800-6:2009 Fire resistance tests. Part 6: Fire propagation test for building façades |
| Ireland | BS 8414 (BR 135) |
| Poland | PN-B-02867:2013 |
| Slovak Republic | ISO 13785-2 |
| Switzerland, Lichtenstein | <ul style="list-style-type: none"> • DIN 4102-20 • ÖNorm B 3800-5 • Prüfbestimmung für Aussenwandbekleidungssysteme |
| UK | BS 8414 -1:2015 and BS 8414-2:2015 |

ANNEX C – WATER ABSORPTION BY CAPILLARITY TEST

C.1 Preparation of the test specimen

Test shall be carried out on at least three specimens.

Specimens shall have a surface area of at least 200 mm x 200 mm, and installed according to the manufacturer's instructions

The following aspects should be recorder in the test report:

- thickness of each layer of the specimen;
- thickness of joints;
- size of the skin pieces;
- weigh of the whole specimen;
- summary of the manufacturer's instruction used for the specimen installation;
- technical information about the components considered in the test specimens.

As it is indicated in section 2.2.3, tests shall be carried out for:

- the whole ETICS, including the skin (cladding element, grout and cladding adhesive) and also;
- the ETICS without the skin (reinforced base coat as external layer).

In the case of the specimens with skin (cladding element, grout and cladding adhesive), the skin shall be prepared taking into account the following criteria:

- if the minimum surface area of the cladding element of the ETICS is equal to or bigger than the surface area of the specimen (e.g. 200 mm x 200 mm), the skin shall be prepared with the configuration of joints as it is shown in figure C.1 with the maximum thickness of joints between the cladding elements;
- if the minimum surface area of the cladding element of the ETICS is smaller than surface area of the specimen (e.g. 200 mm x 200 mm), the skin shall be prepared with the maximum area of joints in the surface area of the specimen.

Exception for not testing these configurations of joints can be accepted provided that a technical argumentation is given.

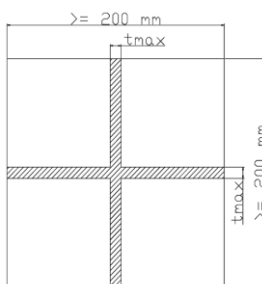

Figure C.1: Configuration of joints for the ETICS skin when the cladding element surface area is equal to or bigger than specimen surface area.

The edges of the specimens (including the insulation panel) should be sealed against water, to ensure that during subsequent testing, only the front face of the ETICS (with and without skin) is subject to water absorption.

C.2 Conditioning of the specimens

The prepared specimens are conditioned for 7 days at (23 ± 2) °C and (50 ± 5) % RH.

They are then subject to a series of 3 cycles comprising the following phases:

- Phase 1: 24 h partial immersion in a water bath (tap water) at (23 ± 2) °C.

The specimens are immersed face downwards, to a depth of 2 to 10 mm, the depth of immersion depends upon surface roughness. To achieve complete wetting of rough surfaces, the specimens shall be tilted as they are introduced into the water. The depth of immersion can be regulated in the water tank by means of a height-adjustable slat.

- Phase 2: 24 h drying at (50 ± 5) °C.

If interruptions are necessary, e.g. at weekends or holidays, the specimens are stored at (23 ± 2) °C and (50 ± 5) % RH after the drying at (50 ± 5) °C.

After the cycles, the specimens are stored for at least 24 h at (23 ± 2) °C and (50 ± 5) % RH.

C.3 Test procedure

To start the capillarity test the specimens are again immersed in a water bath as described above.

The specimens are weighed after 3 minutes immersion in the bath (reference weight) and then after 1 hour and 24 hours. Prior to the second and subsequent weighing, water adhering to the surface of the specimen is removed with a damp sponge cloth.

Note: if the ETICS is applied down to the ground and is therefore exposed to direct contact with earth and the risk of rising damp, the TAB may need to develop additional assessment in an appropriate way subject to consensus within EOTA.

C.4 Test results

Calculation is undertaken to determine the mean value of water absorption per square metre after 1 hour and 24 hours of the three specimens.

ANNEX D– WATER VAPOUR PERMEABILITY

D.1 General

Input data for calculation are the water vapour permeability of the ETICS components.

Water vapour diffusion resistance of the ETICS components (adhesives, thermal insulation panel, reinforced base coat, cladding element and grout) should be obtained from the relevant hEN or EAD.

When the hEN or EAD does not give an assessment method or when there is no relevant hEN or EAD applicable to an ETICS component, the water vapour permeability of this component shall be tested according to EN ISO 12572 if no tabulated values according to EN ISO 10456, EN 12524 or EN 1745 are available. Water vapour permeability of the base coat shall be given together with the reinforcement.

This data can be expressed by means of one of the following terms:

- Water vapour diffusion resistance factor, μ .
- Water vapour diffusion-equivalent air layer thickness, S_d [m].
- Water vapour diffusion resistance, Z , in [m²·s·Pa/kg].
- Water vapour permeance, W , in [kg/(m²·s·Pa)].

The related equations are:

$$Z = 1/W; \quad Z = (d \cdot \mu) / \delta_a; \quad Z = S_d / \delta_a; \quad \mu = \delta_a / \delta; \quad S_d = \mu \cdot d = \delta_a \cdot Z;$$

where:

d = thickness of layer [m].

δ_a = water vapour permeability of the air [kg/(m·s·Pa)] See page 15 of EN ISO 12572 or section 6.2 of EN ISO 13788. $\delta_a = 2,0 \cdot 10^{-10}$ kg/(m·s·Pa) may be used as reference value.

δ = water vapour permeability [kg/(m·s·Pa)]

D.2 Calculation procedure

The water vapour diffusion resistance Z of ETICS can be calculated by the addition of water vapour diffusion resistance of the different layers:

$$Z_{ETICS} = Z_{skin} + Z_{cladd-adhesive} + Z_{base_coat} + Z_{insulation} + Z_{base-adhesive}$$

When relevant, because the skin is configured of the cladding element and the grout of the joints, the water vapour diffusion resistance, Z_{SKIN} , can be calculated by proportionality of the areas of both components.

$$Z_{skin} = Z_{cladding} \cdot P_{cladding} + Z_{grout} \cdot P_{joint}$$

where:

$P_{cladding}$ = percentage surface of cladding element (%)

P_{joint} = percentage surface of joints (%)

ANNEX E – ACCELERATED AGEING PROCEDURES

This annex establishes two types of accelerated ageing tests, which are:

1. Hygrothermal behaviour test (see section E.1), which include:
 - Heat-rain cycles
 - Heat-cold cycles
2. Freeze-thaw behaviour test (see section E.2).

Alternatively, when the manufacturer requires it, a combined hygrothermal and freeze-thaw cycles test may be carried out according to section E.3.

The principle is to determine the effects of accelerated ageing procedures on the ETICS.

After the accelerated ageing procedures, bond strength tests (see section 2.2.8) shall be carried out on samples taken of the test specimens.

The initial test specimens (without accelerated ageing procedures) shall be prepared at the same time that these test samples.

E.1 Hygrothermal behaviour test

E.1.1 Principles related to the preparation of the specimen

The ETICS must be built and applied, in accordance with the manufacturer's instructions, to a sufficiently stabilised masonry or concrete substrate (minimum 28 days).

The test wall shall have one or two openings (depending on the number of exterior skin configurations that are to be tested) positioned as it is indicated in the figures E1.1. The dimension of the weather surface of the test wall shall be:

- width: $\geq 2,50$ m (for one opening) or $\geq 3,00$ m (for two openings)
- height $\geq 2,00$ m

The openings shall be at the upper part of the test wall positioned at a distance $\geq 0,40$ m from the edges (preferably positioned as shown in figures E1.1, for one and two openings). The openings shall have a width and a height of $(0,5 \pm 0,1)$ m.

The configuration of the specimen shall be decided according to the following rules:

- At least the worst case (e.g. maximum water absorption of the ETICS components, maximum area of joints between the claddings, minimum cohesion and adherence of ETICS components, minimum thickness of ETICS components, minimum bonded surface area, minimum density of fixings, etc.) or the more representative case of the ETICS shall be tested.
- As general rule, only one reinforced base coat shall be used for the whole specimen.
- At the very most two exterior skins (different nature of cladding elements, grout and cladding adhesive) can be applied per opening in the test wall (vertical divisions). Maximum two configurations in the case one opening (see figure E1.1a) and maximum four configurations in the case of two openings (see figure E1.1b).

- If several ETICS differ only in the type of insulation panel, two insulation panels can be applied to the test wall (one per opening). If two different insulation products are tested, they shall have the same thickness.
- If different exterior skins are used, the lower part of the test wall ($A = 1/3$ of the total height) consists of the reinforced base coat alone (without any skin).

Any exterior skins not tested on the specimen shall be assessed by means of small specimens $\geq 0,4 \text{ m}^2$ applying the same hygrothermal cycles and subsequent bond strength tests according to section 2.2.8.

The ETICS should also be applied to the lateral faces with a uniform maximum thickness of insulation panel of 20 mm. If the insulation panel is not available in this thickness (e.g. mineral wool lamella), the lateral faces can be covered with a thickness of 20 mm expanded polystyrene.

Special methods for reinforcing corners of the opening are applied, if necessary.

Installation of the window sill and other ancillary materials is under responsibility of the manufacturer.

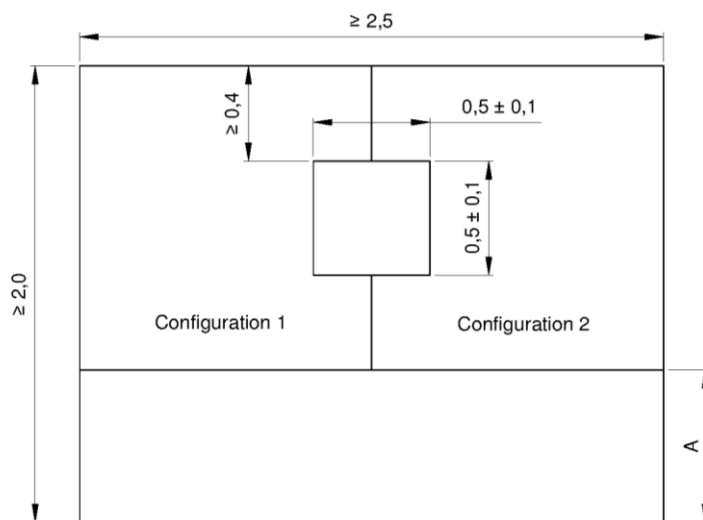

Figure E1.1a: Example of hygrothermal behaviour test specimen with one opening (dimensions in metres).

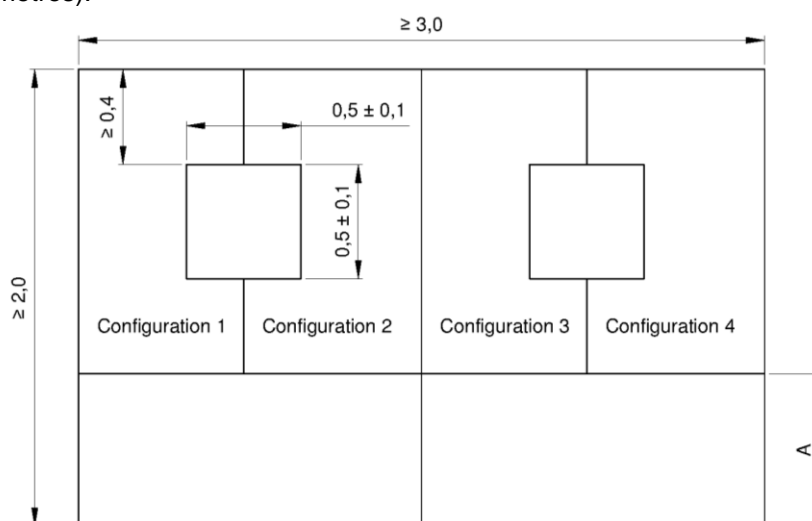

Figure E1.1b: Example of hygrothermal behaviour test specimen with two openings (dimensions in metres).

E.1.2 Preparation of the specimen

The specimen preparation shall be carried out by the manufacturer and be supervised by the laboratory in charge of the test regarding:

- In case of insulation panel requiring stabilisation (prescribed delay between production and sale), verification that it is not older than 15 days beyond the minimum specified period.
- Checking of the respective manufacturer prescriptions: all stages shall be in accordance with the technical documentation of the manufacturer.
- Registering of all the stages of the installation:
 1. the date and time of the various stages,
 2. temperature and % RH during the installation (every day – at least at the beginning),
 3. name and production lot of the components,
 4. way of fixing the insulation panels,
 5. figure describing the specimen (place of the fixings and of the joints between the cladding elements, ...),
 6. way of base coat, grout and adhesives preparation (tool, % of mixing, possible pause time before application,...) as well as their way of application (hand tool, machines, number of layers,...),
 7. quantities and/or thickness of base coat, grout and adhesives applied per square meter,
 8. drying period between each layer,
 9. use and position of accessories,
 10. any other relevant information.

Quantities and/or thicknesses applied shall be recorded as well as identification of the skin components.

E.1.3 Conditioning of the specimen

Each layer shall be cured inside for the time defined by the manufacturer (if no information is given, the whole specimen shall be cured for 28 days). During the curing time the ambient temperature shall be (20 ± 10) °C. The relative humidity shall not be less than 50%. To ensure that these conditions are met, records shall be made at regular intervals.

To prevent the layers from drying out too rapidly the manufacturer may require the layers to be wetted once per week by spraying for approximately 5 minutes. This should start according to the prescriptions of the manufacturer.

During the curing time any deformations of the layers, i.e. blistering, cracking, are recorded.

E.1.4 Hygrothermal cycles

The test apparatus is positioned against the front face of the specimen, 0,10 m to 0,30 m from the edges.

The specified temperatures during the cycles are measured at the surface of the specimen. The regulation shall be obtained by adjustment of the air temperature.

Heat - rain cycles:

The specimen is subjected to a series of 80 cycles (6 hours each cycle), comprising the following phases:

1. Heating to 70°C (rise for 1 hour) and maintaining at (70 ± 5) °C and 10% to 30% RH for 2 hours (total of 3 hours).
2. Spraying for 1 hour, water temperature (15 ± 5) °C, amount of water $(1,5 \pm 0,5)$ l/m² min.
3. Leave for 2 hours (drainage) at (20 ± 5) °C.

Heat-cold cycles:

After at least 48 hours of subsequent conditioning at temperature (20 ± 10) °C and a minimum relative humidity of 50%, the same test specimen is exposed to 5 heat/cold cycles of 24 hours comprising the following phases:

1. Exposure to (50 ± 5) °C (rise for 1 hour) and maximum 30% RH for 7 hours (total of 8 hours).
2. Exposure to $(- 20 \pm 5)$ °C (fall for 2 hours) for 14 hours (total of 16 hours).

E.1.5 Observations during the tests

At periods of every four cycles during the heat/rain cycles and at every cycle during the heat/cold cycles, observations relating to a change in characteristics or performance (blistering, detachment, crazing, loss of adhesion, formation of cracks, etc ...) of the entire ETICS and of the part of the specimen consisting of only the reinforced base coat are recorded as follows:

- the surface finish (base coat or skin) of the ETICS must be examined to establish whether any cracking has occurred. The dimensions and position of any cracks should be measured and recorded,
- the surface should also be checked for any blistering or peeling and the location and extent should again be recorded,
- the sills and profiles should be checked for any damage/degradation together with any associated cracking of the finish. Again, the location and extent should be recorded.

Following the completion of the test, a further investigation is conducted involving removal of sections containing cracks to observe any water penetration within the ETICS.

E.1.6 After the cycles

After the cycles, bond strength tests (see section 2.2.8) shall be carried out on samples taken of the test specimens.

These tests shall be performed after at least 7 days drying.

E.1.7 Test report

The test report shall detail the following:

- Observations recorded during the test (see section E.1.5).
- Photos to detail the damages occurred on each specimen after the cycles and, if necessary, after each visual inspection.

E.2 Freeze-thaw behaviour test

The freeze-thaw test shall be carried out as determined by the analysis of the capillarity test (see section 2.2.3), i.e. shall be done except if the water absorption after 24 hours of both the of the whole ETICS (with skin) determined with each type of skins and the ETICS without skin (reinforced base coat) is less than 0,5 kg/m².

E.2.1 Test specimen preparation

The test shall be carried out on at least three samples ≥ 500 mm x ≥ 500 mm.

These samples are prepared according to the manufacturer's instructions on a masonry or concrete substrate and then stored for at least 28 days at (23 ± 2) °C and (50 ± 5) % RH.

At least the worst case (e.g. maximum water absorption of the ETICS components, maximum area of joints between the claddings, minimum cohesion and adherence of ETICS components, minimum thickness of cladding element and base coat, etc.) or the more representative case of the ETICS shall be tested.

Quantities and/or thicknesses applied shall be recorded as well as identification of the skin components.

The edges of the specimens (including the insulation panel) should be sealed against water, to ensure that during subsequent testing.

E.2.2 Freeze-thaw cycles

The specimens are subjected to a series of 30 cycles (24 hours each cycle) comprising:

1. Exposure to water for 8 hours at $(+23 \pm 4)$ °C by immersion of the specimens, with the skin submerged in a water bath, according to the method described in section 2.2.3.
2. Freezing to (-20 ± 2) °C (fall for 2 hours) for 14 hours (total of 16 hours).

If the test is interrupted, because the specimens are handled manually and there are stops during weekends or holidays the specimens shall always be stored at a temperature of (-20 ± 2) °C between the cycles.

Remark: the specified temperatures are measured at the surface of the samples. The regulation is obtained by conditioned air.

E.2.3 Observations

At the end of the test, observations relating to a change in characteristics of the surface or to the behaviour of the entire ETICS are recorded according to section E.1.5.

Any distortion at the edges of the samples shall also be reported.

E.2.4 After the cycles

After the freeze-thaw cycles, bond strength tests (see section 2.2.8) shall be carried out on each specimen submitted to freeze-thaw cycles.

These tests shall be performed after at least 7 days drying.

E.2.5 Test report

See section E.1.7.

E.3 Alternative test with combined hygrothermal and freeze-thaw cycles

E.3.1 Principles related to the preparation of the samples

See section E.1.1.

E.3.2 Preparation of the specimen

See section E.1.2.

E.3.3 Conditioning of the specimen

See section E.1.3.

E.3.4 Hygrothermal cycles

The test apparatus is positioned against the front face of the specimen, 0,10 m to 0,30 m from the edges.

The specified temperatures during the cycles are measured at the surface of the specimen. The regulation shall be obtained by adjustment of the air temperature.

Heat - rain cycles:

The specimen is subjected to a series of 80 cycles (6 hours each cycle), comprising the following phases:

1. Heating to 70°C (rise for 1 hour) and maintaining at (70 ± 5) °C and 10% to 30% RH for 2 hours (total of 3 hours).
2. Spraying for 1 hour, water temperature (15 ± 5) °C, amount of water $(1,5 \pm 0,5)$ l/m² min.
3. Leave for 2 hours (drainage) at (20 ± 5) °C.

Heat-cold cycles:

After at least 48 hours of subsequent conditioning at temperature (20 ± 10) °C and a minimum relative humidity of 50%, the same test specimen is exposed to 5 heat/cold cycles of 24 hours comprising the following phases:

1. Exposure to (50 ± 5) °C (rise for 1 hour) and maximum 30% RH for 7 hours (total of 8 hours).
2. Exposure to $(- 20 \pm 5)$ °C (fall for 2 hours) for 14 hours (total of 16 hours).

Freeze-thaw cycles:

After at least 48 hours of subsequent conditioning at temperature (20 ± 10) °C and a minimum relative humidity of 50%, the same test specimen is exposed to:

Conditioning the test specimen spraying for 8 hours, water temperature (15 ± 5) °C, amount of water $(1,5 \pm 0,5)$ l/m² min.

30 freeze/thaw cycles of 8 hours comprising the following phases:

1. Freeze the surface of the specimen at least 2 hours to $(- 20 \pm 5)$ °C and maintain it for 4 hours (in total 6 hours).
2. Thaw the specimen for 1 hour at temperature of (20 ± 5) °C.
3. Spraying for 8 hours, water temperature (15 ± 5) °C, amount of water $(1,5 \pm 0,5)$ l/m² min.

After the 30 cycles condition specimen at ambient temperature (20 ± 10) °C.

E.3.5 Observations during the tests

At periods of every four cycles during the heat/rain cycles and at every cycle during the heat/cold cycles and freeze-thaw cycles, observations relating to a change in characteristics or performance (blistering, detachment, crazing, loss of adhesion, formation of cracks, etc ...) of the entire ETICS and of the part of the specimen consisting of only the reinforced base coat are recorded as follows:

- the surface finish (base coat or skin) of the ETICS must be examined to establish whether any cracking has occurred. The dimensions and position of any cracks should be measured and recorded,
- the surface should also be checked for any blistering or peeling and the location and extent should again be recorded,
- the sills and profiles should be checked for any damage/degradation together with any associated cracking of the finish. Again, the location and extent should be recorded.

Following the completion of the test, a further investigation is conducted involving removal of sections containing cracks to observe any water penetration within the ETICS.

E.3.6 After the cycles

See section E.1.6.

E.3.7 Test report

See section E.1.7.

ANNEX F – WIND LOAD RESISTANCE TEST

The principle is to establish the effects of suction and pressure loads on the ETICS.

The number of tests depends on the combination of parameters presented for the ETICS.

At least, the mechanically weakest design shall be tested.

F.1 Wind suction test

F.1.1 Preparation of the test specimen

The test specimen shall be mounted in the test equipment in accordance with the manufacturer instructions.

The test specimen is defined as follows:

- A non-airtight substrate (test rig) such as wood or steel rigid frame or masonry or concrete wall with holes that allow the pass of the air between the chamber and the environment.
- The ETICS must be fixed to the test rig without supplementary base adhesive.
- The dimensions of the test specimen depend on the size of external cladding element and the size of the thermal insulation panels:
 - for ETICS which are mechanically fixed independent of each other (anchors placed at the body of the insulation panels), a minimum surface of 1,5 m² shall be tested.
 - for ETICS which are mechanically fixed dependent on each other vertically and horizontally (anchors placed at joints of the insulation panels), at least 3 x 3 panels shall be tested.
 - for ETICS which are mechanically fixed dependent on each other vertically or horizontally (anchors placed at joints of the insulation panels), at least 4 elements shall be tested.
- To define the mechanically weakest design the following aspects shall be taken into account:
 - The mechanically weakest insulation panel (e.g. minimum thickness, minimum tensile strength perpendicular to the surface, etc.).
 - The mechanically weakest cladding element (e.g. minimum thickness, minimum bending strength, etc.).
 - Minimum density of anchors.

The tolerances due to manufacturing and/or installation and deformations due to temperature and humidity variations have to be taken into account.

F.1.2 Test equipment

The test equipment consists of a pressure or suction chamber (see figure F.1) against which is placed the ETICS. The depth of chamber shall be sufficient for a constant pressure or suction to be exerted on the test specimen applied to the external surface of the ETICS irrespective of its possible deformation. The chamber is mounted on a rigid frame. The ETICS acts as the seal between the chamber and the environment. The connection between the ETICS and the chamber shall be sufficient to allow a realistic deformation of the test specimen under the influence of simulated wind suction.

F.1.3 Test procedure

The uniformly distributed loads are exerted on the surface of the ETICS.

The test is performed in successive steps (two steps of 300 Pa, one step of 500 Pa and one step of 1000 Pa, then steps of +200 Pa thereafter, at each step the load is maintained constant for at least 10 seconds and returned to zero after each step; see figure F.2) until significant irreversible deformation (deformation which affects serviceability) or failure occurs.

The test is then continued until failure occurs.

The deflection shall be measured, at the relevant points (e.g. central point of the cladding element or insulation panel, border or corner of the cladding element or insulation panel, etc.), as a function of the load and reported in tabular or graphic form.

With the differential pressure reduced to zero, the permanent deflection shall be noted after 1 minute recovery. The pressure at which defect or damage occur shall be noted.

Additionally, if relevant, the permanent deflection 1 hour after failure occurs shall be noted.

The fixings between the ETICS and the test equipment shall not constitute weak points and shall therefore be chosen accordingly.

F.1.4 Observations during the test

Failure is defined by any one of the following events:

- Any ETICS component breaks.
- Any delamination occurs in the insulation panel or between components.
- Any skin detaches.
- Any ETICS component is pulled off a fastener.

F.1.5 Test results

The test result is:

- The failure load Q.
- The type of failure.
- The value of maximum permanent deflection (after 1 minute recovery), the maximum deflection of the test specimen and the load and sensor position for this maximum permanent deflection and maximum deflection.

F.1.6 Test specimen description

It is necessary to describe the test specimen by giving details about ETICS components (material, geometry and number and disposition of anchors).

F.2 Wind pressure test

The test procedure is similar to section F.1, the only difference being that the wind action is reversed.

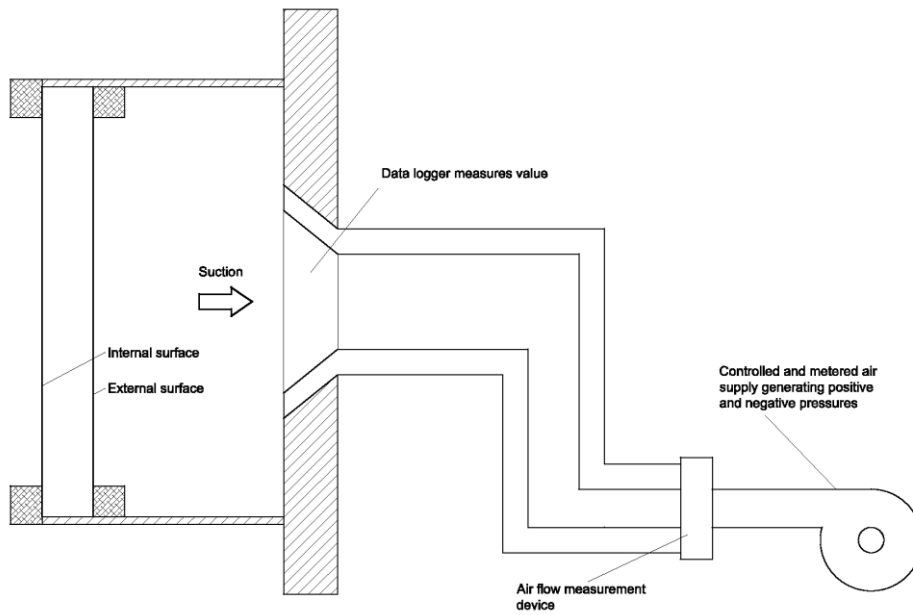

Figure F.1: Example of wind pressure and suction apparatus.

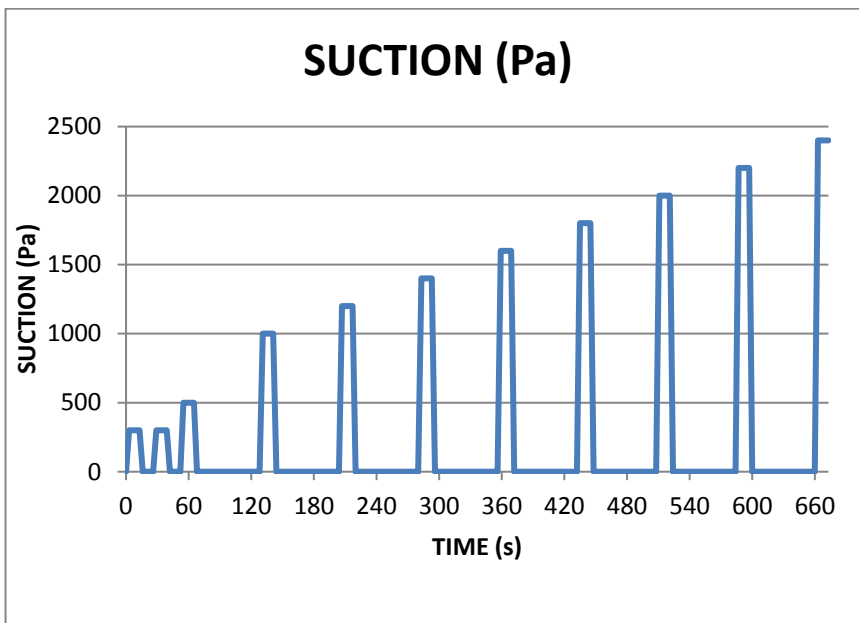

Figure F.2: Example of wind load steps.

ANNEX G – IMPACT RESISTANCE TEST

G.1 General

The principle is to establish the impact resistance of the ETICS to hard body and soft body impacts. Besides, this annex includes the impact use categories to correspond to the degree of exposure to impacts in use.

The impact bodies and the test equipment are indicated in EOTA TR001.

The points of impact shall be selected taking into account the behaviour of the cladding element, varying according to whether the impact point is or is not located in an area of greater rigidity (at less than 50 mm from the edge of cladding element).

Hard body impacts are:

- H1 and H2 (1 J and 3 J respectively), carried out with the steel ball weighing 0,5 kg and from a height of 0,20 m and 0,61 m respectively (at least in three locations).
- H3 (10 J), carried out with the steel ball weighing 1,0 kg and from a height of 1,02 m (at least in three locations).

Soft body impacts are:

- Small soft body S1 and S2 (10 J and 60 J respectively), carried out with the soft ball weighing 3,0 kg and from a height of 0,34 m and 2,04 m respectively (at least in three locations).
- Large soft body S3 and S4 (100 J and 400 J respectively), carried out with the spherical bag weighing 50,0 kg and from a height of 0,61 m and 0,82 m respectively (at least in the space between two profiles).

Note: National building regulations in some member states may have specific requirements. The TAB may consider other energy values for the hard and soft body impacts. Any change shall be indicated in the ETA.

At least, the mechanically weakest design shall be tested.

The size of the test specimen shall be chosen to carry out all the impacts indicated in table G.1.

The dimensions of any indentation shall be reported. Noted shall be made of any damage caused.

G.2 Test procedure

Test procedure can be carried out using one of following options:

1. When the impact resistance is chosen by the manufacturer or it is known, using the impact tests indicated in table G.1 for this impact resistance chosen or known.
2. When the impact resistance is not known, using the sequence for the impact tests, indicated in table G.2, with the aim of obtaining the maximum impact resistance.

Table G.1: Hard and soft body impact tests.

| External impacts and assessment | | | | | | |
|---------------------------------------------------------------------------------------------------------------------------------------------------------------------------------------------------------------------------------------------------------------------------------------------------------------------------------------------------------------------------------------------------------------------------------------------------------------------------------------------------------------------------------|----|-------------------------------------------------------------------------------------------------------------------------------------------------------------------------------------------------------------------------|----------------------------------------------------|----------------------------------------------------|----------------------------------------------------|---------------------------|
| | | | Category IV | Category III | Category II | Category I |
| Hard body impact | H1 | <ul style="list-style-type: none"> • Weight: 0,5 kg • Impact: 1 J (height 0,20 m) • No. impacts: 3 • Position of impacts: three different locations | Skin not penetrated (2) Skin not perforated (3) | --- | --- | --- |
| | H2 | <ul style="list-style-type: none"> • Weight: 0,5 kg • Impact: 3 J (height 0,61 m) • No. impacts: 3 • Position of impacts: three different locations | --- | Skin not penetrated (2) Skin not perforated (3) | Skin not deteriorated (1) | Skin not deteriorated (1) |
| | H3 | <ul style="list-style-type: none"> • Weight: 1 kg • Impact: 10 J (height 1,02 m) • No. impacts: 3 • Position of impacts: three different locations | --- | --- | Skin not penetrated (2) Skin not perforated (3) | Skin not deteriorated (1) |
| Soft body impact | S1 | <ul style="list-style-type: none"> • Weight: 3 kg • Impact: 10 J (height 0,34 m) • No. impacts: 3 • Position of impacts: three different locations | Skin not deteriorated (1) | Skin not deteriorated (1) | --- | --- |
| | S2 | <ul style="list-style-type: none"> • Weight: 3 kg • Impact: 60 J (height 2,04 m) • No. impacts: 3 • Position of impacts: three different locations | --- | --- | Skin not deteriorated (1) | Skin not deteriorated (1) |
| | S3 | <ul style="list-style-type: none"> • Weight: 50 kg • Impact: 300 J (height 0,61 m) • No. impacts: 1 • Position of impacts: At least in the centre point of a cladding element | --- | --- | Skin not deteriorated (1) | --- |
| | S4 | <ul style="list-style-type: none"> • Weight: 50 kg • Impact: 400 J (height 0,82 m) • No. impacts: 1 • Position of impacts: At least in the centre point of a cladding element | --- | --- | --- | Skin not deteriorated (1) |
| <p>(1) Superficial damage, provided there is no cracking, is considered as showing "no deterioration" for all the impacts.</p> <p>(2) The test result is assessed as being "penetrate" if there is any cracking penetrating (internal layers are observed) to be observed in the cladding element in at least 2 of 3 impacts. Superficial cracking (not penetrating) is allowed.</p> <p>(3) The test result is assessed as being "perforated" if there is a destruction of the cladding element in at least 2 of 3 impacts.</p> | | | | | | |

G.3 Impact test sequence

When the impact resistance is not known, it is possible to obtain the maximum impact resistance following the increasing sequence for the impact tests, indicated in the table G.2.

To start the sequence indicated in the table G.2, it is considered that the ETICS might have the maximum impact resistance (impact use category I). If it is necessary, the manufacturer can choose to start the sequence from other impact resistance.

Table G.2: Impact test sequence.

| | |
|--------------------------------------------------------------------------------------------------------------|--------------------------------------------------------------------------------------------------------------------------------------------------------------------------------------------------------------------------------------------------------------------------------------------|
| Impact H2 | In the case of no cracks appear, then carry out the hard body impact H3. |
| | In the case of superficial cracks appear but without penetrations or breaks (no penetrated and no perforated), then carry out the soft body impact S1. If the S1 impact result is satisfactory, the ETICS should be classified as Category III. |
| | In the case of penetrations or breaks appear, then carry out the hard body impact H1 and after that, the soft body impact S1. If the H1 and S1 impact results are satisfactory, the ETICS should be classified as Category IV. |
| Impact H3 | In the case of no cracks appear, then carry out the soft body impact S2. |
| | In the case of superficial cracks appear but without penetrations or breaks (no penetrated and no perforated), then carry out the soft body impact S2. |
| | In the case of penetrations or breaks appear, then carry out the soft body impact S1. If the S1 impact result is satisfactory, the ETICS should be classified as Category III. |
| Impact S2 | In the case of no cracks appear, and no cracks have appeared during the hard body impact H3, the TAB and the manufacturer may choose if carry out the soft body impact S4 directly (to obtain the Category I) or carry out the S3 impact (to secure the Category II) before the S4 impact. |
| | In the case of cracks, penetrations or breaks appear; carry out the soft body impact S1. If the S1 impact result is satisfactory, the ETICS should be classified as Category III or IV (taking into account the hard body impact results). |
| Impact S3 | In the case of no cracks appear, and hard body impacts H2 and H3 have been satisfactory, the ETICS should be classified as Category II. |
| | In the case of cracks, penetrations or breaks appear; carry out the soft body impact S1. If the S1 impact result is satisfactory, the ETICS should be classified as Category III or IV (taking into account the hard body impact results). |
| Impact S4 | In the case of no cracks appear, and hard body impacts H2 and H3 have been satisfactory, the ETICS should be classified as Category I. |
| | In the case of cracks, penetrations or breaks appear; and the soft body impact S3 has not been carried out previously, then carry out the soft body impact S3. |
| NOTE: In the case of the H1 or S1 impact results will not be satisfactory, the ETICS must not be classified. | |

G.4 Definition of the impact use categories

The categories given in table G.3 correspond to the degrees of exposure in use. They do not include an allowance for acts of vandalism.

Table G.3: Impact use categories.

| Category | Use |
|----------|---------------------------------------------------------------------------------------------------------------------------------------------------------------------------------------------------------------------------------------------------------------------------------------------------------------------------------------------------------------------------------------------------------------------------------------------------------------------------------------------------------------------------------------------------|
| I | A zone readily accessible at ground level to the public and vulnerable to hard body impacts but not subjected to abnormally rough use. (e.g.: Façade bases in buildings sited in public locations, such as squares, schoolyards or parks. Cleaning gondolas can be used on the façade). |
| II | A zone liable to impacts from thrown or kicked objects, but in public locations where the height of the kit will limit the size of the impact; or at lower levels where access to the building is primarily to those with some incentive to exercise care (e.g.: Façade bases in buildings not sited in public locations (e.g. squares, schoolyards, parks) or upper façade levels in buildings sited in public locations that occasionally can be hit by a thrown object (e.g. ball, stone, etc.). Cleaning gondolas can be used on the façade). |
| III | A zone not likely to be damaged by normal impacts caused by people or by thrown or kicked objects (e.g.: Upper façade levels in buildings (not including base) not sited in public locations, that occasionally can be hit by a thrown object (e.g. ball, stone, etc.). Cleaning gondolas cannot be used on the façade). |
| IV | A zone out of reach from ground level (e.g. High façade levels that cannot be hit by a thrown object. Cleaning gondolas cannot be used on the façade). |

ANNEX H – BOND STRENGTH TEST

H.1 General

Tests shall be carried out for the connections between the main layers of the ETICS and conditionings indicated in table H.1.

| Bond strength | Specimen conditioning (i) | Bond strength minimum level (MPa) |
|---------------------------------------------------------------------------------------------------------------------------------------------------------------------------------------------------------------------------------------------------------------------------------------------------------------------------------------------------------------------------------------------------------------------------------------------------------------------------------------------------------------------------------------------------------------------------------------------------------------------------------------------------------------------------------------------------------------------------------------------------------------------------------------------------------------------------------------------------------------------------------------------------------------------------------------------------------------|----------------------------------------|-----------------------------------|
| Connection 1: Between the external layers (skin and reinforced base coat) and the insulation panel | a) dry conditions | ≥ 0,08 (iii) |
| | b) 2 d. H ₂ O + 2 h. drying | |
| | c) 2 d. H ₂ O + 7 d. drying | |
| | d) after hygrothermal cycles (ii) | |
| | e) after freeze-thaw cycles | |
| Connection 2: Between the insulation panel and the base adhesive | a) dry conditions | ≥ 0,08 (iii) |
| | b) 2 d. H ₂ O + 2 h. drying | |
| | c) 2 d. H ₂ O + 7 d. drying | |
| Connection 3: Between the base adhesive and the substrate | a) dry conditions | ≥ 0,25 (iv) |
| | b) 2 d. H ₂ O + 2 h. drying | ≥ 0,08 (iii) |
| | c) 2 d. H ₂ O + 7 d. drying | ≥ 0,25 (iv) |
| (i) The different conditionings are defined as: a) after at least 28 days curing at (23 ± 2) °C and (50 ± 5) % RH, i.e. without any supplementary conditioning (on dry conditions); b) after immersion in water for 2 days and 2 hours drying at (23 ± 2) °C and (50 ± 5) % RH after removing the samples from the water; c) after immersion in water for 2 days and 7 days drying at (23 ± 2) °C and (50 ± 5) % RH after removing the samples from the water; d) on samples taken from the specimen after hygrothermal cycles (see section 2.2.5.1) or after the alternative test combining hygrothermal and freeze-thaw cycles (see section 2.2.5.3); e) on specimens after freeze-thaw cycles (see section 2.2.5.2). (ii) On samples taken from the specimen. (iii) One single value lower than 0,08 MPa but higher than 0,06 MPa is admissible. (iv) One single value lower than 0,25 MPa but higher than 0,20 MPa is admissible. | | |

Table H.1: Bond strength. Conditioning and minimum level.

H.2 Preparation of the test specimen

Samples with appropriate size to obtain the cut specimens shall be prepared according to the manufacturer's instructions. Components used, thickness, weight and method of application shall be recorded.

Samples are cured at least 28 days at (23 ± 2) °C and (50 ± 5) % RH (conditioning indicated as a) in table H.1).

Test shall be carried out on at least five specimens, for each connection and conditioning, obtained by cut on the large sample size.

For the connection 1 and connection 2 indicated in table H.1 above, each specimen shall have a square surface with dimension equivalent to the specimens for testing the tensile strength of the insulation panel (see section 2.2.9).

For the connection 3 indicated in table H.1 above, each specimen shall have a square surface with dimension 50 mm x 50 mm.

The square specimens are cut through the layers according to figure H.1 using an angle grinder. At least 50 mm of distance is necessary between each square specimen and with the border of the sample. Square metal plates of appropriate size are affixed to these areas with a suitable adhesive.

H.3 Test procedure

The bond strength test (see figure H.1) is performed at a tensioning speed between 1 to 10 mm/minute.

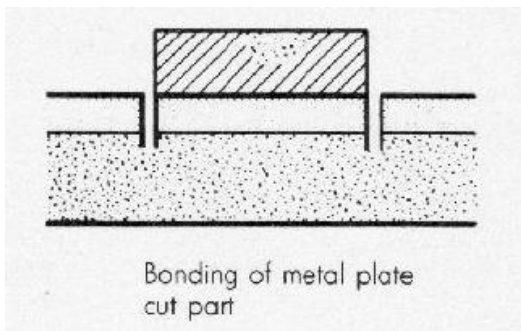

Figure H.1: Bond strength test.

H.4 Test results

Each individual value of bond strength and the rupture type (cohesive rupture and/or adhesive rupture) shall be recorded.

H.5 Calculation of the minimal admissible bonded surface area

In the case of bonded ETICS with supplementary mechanical fixings, the bonded surface area (S) shall exceed 40% and is calculated as follows:

$$S (\%) = (0,08 \times 100)/B$$

where:

- B = minimum failure resistance of the bond strength test between the insulation panel and the base adhesive in dry conditions expressed in MPa.
- 0,08 MPa correspond to the minimum requirement indicated in table H.1.

ANNEX I – DEAD LOAD BEHAVIOUR TEST

I.1 General

The principle is to establish the effects of dead loads on the ETICS.

The test on bonded ETICS with supplementary mechanical fixing devices shall be conducted without the fixings. In the same way, the test on mechanically fixed ETICS with supplementary adhesive shall be conducted without the adhesive.

At least the worst case (e.g. maximum thickness and minimum tensile strength perpendicular to the surface of insulation panel, maximum thickness and weight of skin, maximum transverse deformation of the adhesives, minimum density of mechanical fixings, etc.) or the more representative case of the ETICS shall be tested.

The test shall be carried out under normal environmental laboratory conditions (20 ± 10) °C and (50 ± 20) % relative humidity.

Test shall be carried out on at least three specimens.

The ETICS specimens shall have a surface area of at least 200 mm x 200 mm.

In the case of bonded ETICS with supplementary mechanical fixing devices, the specimens shall be bonded on a masonry or concrete substrate, in accordance with the manufacturer's instructions. These topics shall be recorded.

In the case of mechanically fixed ETICS with supplementary adhesive, the specimens shall be fixed on a masonry or concrete substrate, by one anchor through the thermal insulation panel in the middle point of the specimen, in accordance with the manufacturer's instructions. These topics shall be recorded.

Five steps are necessary to carry out the test:

- Step 1: no additional dead load is added on the skin layer.
- Step 2: an additional dead load, $F_{ad} = 0,25 \times F_{ref}$ is added on the skin layer.
- Step 3: an additional dead load, $F_{ad} = 0,50 \times F_{ref}$ is added on the skin layer.
- Step 4: an additional dead load, $F_{ad} = 0,75 \times F_{ref}$ is added on the skin layer.
- Step 5: an additional dead load, $F_{ad} = 1,00 \times F_{ref}$ is added on the skin layer.

Where the reference load F_{ref} must be obtained as is indicated in section I.2.

The displacement at the skin layer shall be measured.

For each step, the test shall be carried out at least during 24 hours unless the difference between the measured displacements is equal to or less than 0,1 mm after two successive measurements in 1 hour.

Dead loads applied, differences of displacement obtained and the deflection curves in function of the time shall be recorded.

I.2 Reference load (F_{ref})

I.2.1 Bonded ETICS with supplementary mechanical fixing devices

In the case of bonded ETICS with supplementary mechanical fixing devices, for obtaining the reference load (F_{ref}), one of the following options can be considered:

Option 1 – Considering the limits of both, bond strength between ETICS layers and insulation shear strength:

The reference load, in N, must be obtained according the following equation:

$$F_{ref} \geq 0,80 \times \left[\min \left(\frac{0,08 \times A \times h}{6 \times d} ; 0,02 \times A \right) - Q_{spec} \times A \right]$$

Where:

A = area, in mm, of the specimen (e.g. 200 mm x 200 mm);

h = high, in mm, of the specimen (e.g. 200 mm);

d = distance, in mm, between the substrate to the point of the load application (addition of layer thickness:

$$d = t_{base-adhesive} + t_{insulation} + t_{base-coat} + t_{cladd-adhesive} + 0,5 \times t_{skin}$$

Q_{spec} = mass per unit area, in MPa, of the specimen.

Option 2 – Considering the results of a previous test applying a load at constant speed rate:

A previous test on an specimen with the same dimension to be considered in the dead load test (e.g. 200 mm x 200 mm) must be carried out.

A force must be exerted at a constant speed rate of 5 mm/min (see figure I.1) until failure (specimen breaks). The ultimate force (F_{u_test}) and the graphic of displacements and forces measured shall be recordered.

The test shall be conducted without the supplementary fixing devices.

After the previous test, the reference load, in N, must be obtained according the following equation:

$$F_{ref} \geq 0,50 \times F_{u_test}$$

Where:

F_{u_test} = ultimate force, in N, obtained from the previous test.

I.2.2 Mechanically fixed ETICS with supplementary adhesive

In the case of mechanically fixed ETICS with supplementary adhesive, for obtaining the reference load (F_{ref}), the option 2 given in section I.2.1 must be considered taking into account the figure I.2.

The test shall be conducted without the supplementary adhesive.

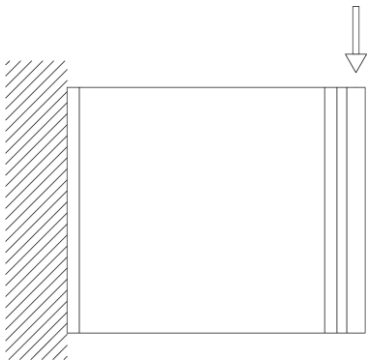

Figure I.1: Configuration for bonded ETICS with supplementary mechanical fixing devices.

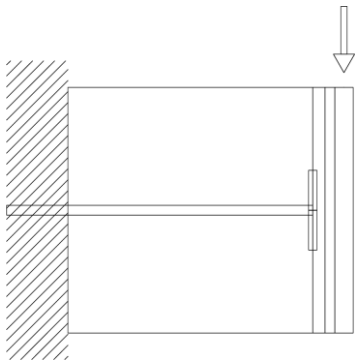

Figure I.2: Configuration for mechanically fixed ETICS with supplementary adhesive.

ANNEX J – MECHANICALLY FIXED ETICS TESTS

This annex establishes two types of mechanically fixed ETICS tests, which are:

- Pull-through resistance test (see section J.1).
- Pull-out resistance. Static foam block test (see section J.2).

J.1 Pull-through resistance test

The pull-through resistance test is only required for mechanically fixed ETICS with supplementary adhesive when the anchors are fixed through the thermal insulation panel.

The test is performed in dry conditions.

However, if the tensile strength of the insulation panel in wet conditions tested in section 2.2.9 is less than 80% of that determined in dry conditions, the pull-through test shall be carried out in wet conditions as described in section 2.2.9 for 28 days exposure.

At least the worst case (e.g. minimum thickness of insulation panel, minimum tensile strength perpendicular to the faces or cohesion of the insulation panel, minimum plate diameter of anchor, minimum plate stiffness of anchor, minimum load resistance of anchor (see EOTA TR 026)) shall be tested.

Depending on the position of the anchor in the insulation panel (according to the instructions of the manufacturer) the following tests shall be carried out:

- If the anchors are only placed in the body of the insulation panel, pull-through resistance R_{panel} according to the sample configuration indicated in figure J.1.1 shall be tested.
- If the anchors are placed at the insulation panel joints, pull-through resistance R_{panel} and R_{joint} according to both sample configurations indicated in figure J.1.1 and figure J.1.2 shall be tested.

Insulation samples, measuring 350 mm x 350 mm, with an anchor driven through the centre of each sample (see figure J.1.1) or at panel joints as described at the figure J.1.2, are bonded, using a suitable adhesive, to a rigid substrate. The head of the anchor is covered previously with a self-release sheet.

When the adhesive has cured, a pulling force is exerted, at a loading rate of 20 mm/min between the rigid plate and the end of the anchor protruding through the insulation panel until failure (see figure J.1.3).

At least 5 specimens (depending on the dispersion of the results) shall be tested. However, historical data obtained from testing of 3 samples may be used.

Results are void if the rupture occurs in the edge. In such cases, the dimensions of the sample shall be increased (bigger than 350 mm x 350 mm).

The test report shall detail:

- each individual and mean values expressed in N,
- load/displacement graphs for all test specimens,
- tensile strength perpendicular to the face of the insulation panel tested (test result according to EN 1607).

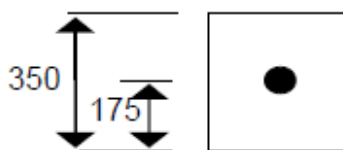

Figure J.1.1: Configuration where the anchor is placed in the centre of the insulation panel samples.

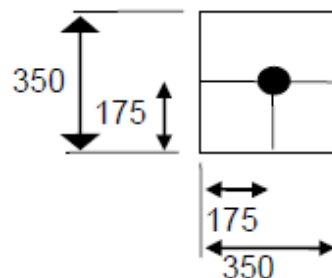

Figure J.1.2: Configuration where the anchor is at panel joints of the insulation panel samples.

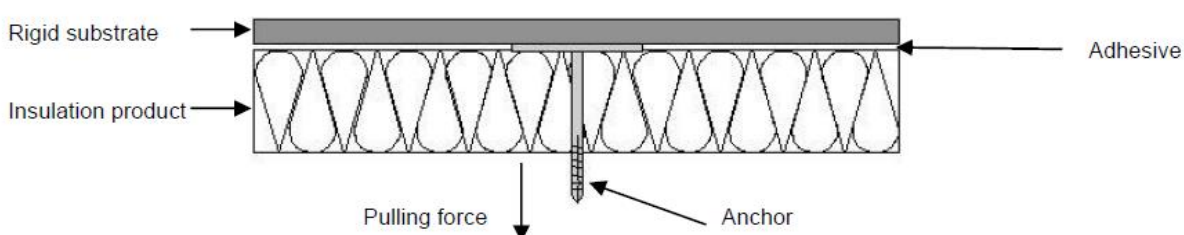

Figure J.1.3: Pull-through test.

J.2 Pull-out resistance. Static foam block test

The pull-out resistance test is only required for mechanically fixed ETICS with supplementary adhesive, in both cases, when the anchors are fixed through the reinforcement mesh and when the anchors are fixed through the thermal insulation panel.

The test is performed in dry conditions.

However, if the tensile strength of the insulation panel in wet conditions tested in section 2.2.9 is less than 80% of that determined in dry conditions, the pull-through test shall be carried out in wet conditions as described in section 2.2.9 for 28 days exposure.

At least the worst case (e.g. minimum thickness of insulation panel, minimum tensile strength perpendicular to the faces or cohesion of the insulation panel, minimum plate diameter of anchor, minimum plate stiffness of anchor, minimum load resistance of anchor (see EOTA TR 026)) shall be tested.

The ETICS without skin is applied to a concrete slab without any supplementary adhesive, in accordance with the manufacturer's installation instructions.

The dimensions shall be chosen according to the standard production size of the insulation panels and with the minimum thickness.

Test samples are prepared without the skin, in accordance with the manufacturer's instructions and taking into account the influence of the anchors positioned at the panel joints as illustrated in figures J.2.1 and J.1.2.

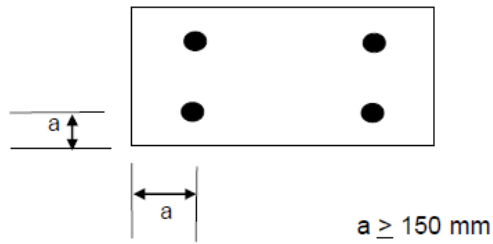

Figure J.2.1: Configuration when the anchor is placed in the body of the insulation samples.

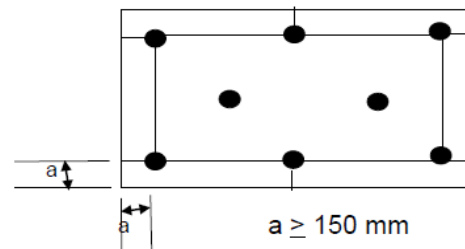

Figure J.2.2: Configuration when anchor is placed at panel joints of the insulation panel samples.

For cellular plastic insulation panels, at least 3 specimens (depending on the dispersion of the results) shall be tested.

For mineral wool insulation panels, at least 5 specimens (depending on the dispersion of the results) shall be tested.

Test details are illustrated in figure J.2.3. The testing load F_t is generated by a hydraulic jack and transferred via a load cell to a plywood or other rigid panel. The loading speed shall be in the order of 10 ± 1 mm/minute. The joists are fixed with timber screws to a plywood panel and the timber panel is glued to the foam blocks using a two-component epoxy adhesive. Due to the surface of the sample is not directly accessible; the displacement of the base coat surface is measured via an extension rod passing through a hole in one of the foam blocks.

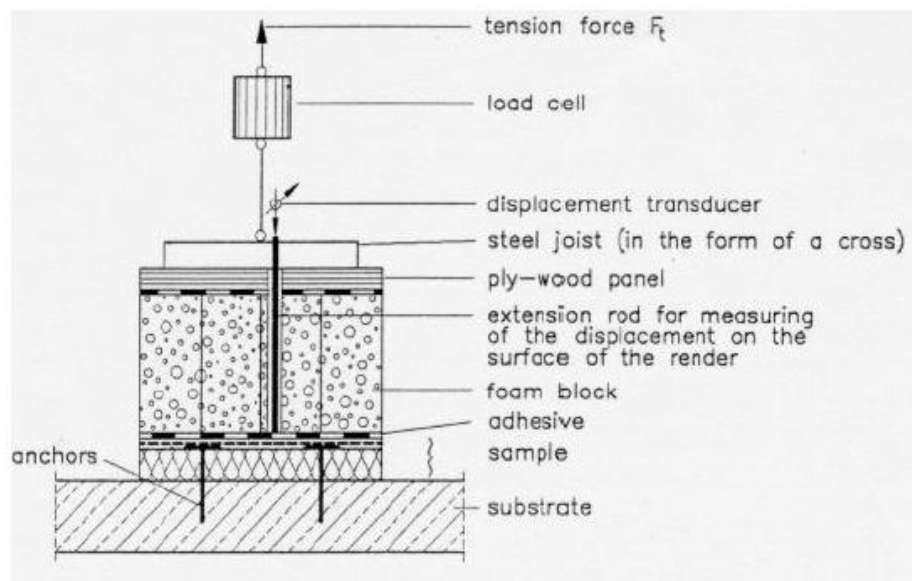

Figure J.2.3a: Pull-out resistance. Static foam block test. Specimen.

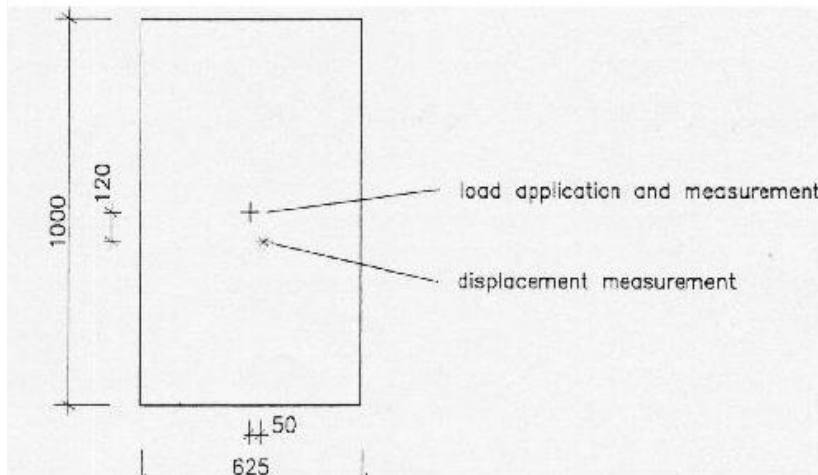

Figure J.2.3b: Pull-out resistance. Static foam block test. Points of measurement.

The foam blocks shall be weak enough to follow all displacements of the base coat without affecting the bending stiffness of the ETICS. Therefore the blocks are cut to rectangular pieces not exceeding 300 mm x 300 mm in width. The height of the blocks shall be at least 300 mm.

Comment: A suitable initial length of the block elements is 500 mm. The blocks can be cut off with a hot wire after the test is finished. They may be reused at least 20 times until the remaining length reaches about 300 mm.

The tensile strength of the foam blocks material shall be in the range of 80 kPa to 150 kPa, the rupture strain shall exceed 160%. The compressive strength according to ISO 3386-1 or -2 shall be in the order of 1,5 kPa to 7,0 kPa. An example of a suitable material is polyether foam.

The test report shall detail the failure loads, the individual values and the mean value obtained as well as the tensile strength perpendicular to the face of the insulation panel tested.

ANNEX K – THERMAL RESISTANCE VALUES

This annex establishes a calculation procedure to obtain the thermal resistance of the whole ETICS using the thermal resistance of each ETICS component.

K.1 General

The additional thermal resistance provided by the ETICS (R_{ETICS}) to the substrate wall is calculated from the thermal resistance of the ETICS components:

- Thermal insulation panel ($R_{insulation}$) shall be given according to the relevant harmonized standard;
- Reinforced base coat (R_{base_coat}), adhesives ($R_{adhesive}$) and grout (R_{grout}) shall be obtained either from tabulated values according to EN ISO 10456 or EN 1745, or from measured values according to EN 12939, EN 12667 or EN 12664 or, when relevant, according to the harmonized standard.
- Cladding element ($R_{cladding}$) shall be given either by tabulated values according to EN ISO 10456 or according to relevant harmonized standard;
- When relevant, because the external layer of the skin is configured of the cladding element and the grout in the joints, the thermal resistance of this layer (R_{skin}), can be calculated by proportionality of the areas of both components.

$$R_{skin} = R_{cladding} \cdot P_{cladding} + R_{grout} \cdot P_{joint} \quad [W/(m^2 \cdot K)]$$

Where:

$P_{cladding}$ = percentage surface of cladding element (%)

P_{joint} = percentage surface of joints (%)

K.2 Calculation procedure

The thermal resistance of the whole ETICS (R_{ETICS}) can be calculated by the addition of thermal resistance of the different layers as described in EN ISO 6946 and EN ISO 10456:

$$R_{ETICS} = R_{skin} + R_{cladd-adhesive} + R_{base_coat} + R_{insulation} + R_{base-adhesive} \quad [W/(m^2 \cdot K)]$$

If the thermal resistance cannot be calculated, it can be measured on the complete ETICS as described in EN 1934.

The thermal bridges caused by mechanical fixing devices influence the thermal transmittance of the whole external wall and shall be taken into account using the following calculation:

$$U_c = U + \Delta U \quad [W/(m^2 \cdot K)]$$

where:

U_c = corrected thermal transmittance of the whole external wall, including thermal bridges;

U = thermal transmittance of the whole external wall, including ETICS, without thermal bridges;

$$U = \frac{1}{R_{si} + R_{substrate} + R_{ETICS} + R_{se}}$$

- $R_{\text{substrate}}$ = thermal resistance of the substrate wall [W/(m²·K)]
- R_{se} = external surface thermal resistance [W/(m²·K)]
- R_{si} = internal surface thermal resistance [W/(m²·K)]
- ΔU = correction term of the thermal transmittance for mechanical fixing devices = $X_p \cdot n_{\text{fix}}$ (for anchors)
- X_p = point thermal transmittance value of the anchor [W/K] (see EOTA TR025). If not specified in the anchors ETA, the following values apply:
- = 0,002 W/K for anchors with a plastic screw/nail, stainless steel screw/nail with the head covered by plastic material, and for anchors with an air gap at the head of the screw/nail;
 - = 0,004 W/K for anchors with a galvanized steel screw/nail with the head covered by a plastic material;
 - = 0,008 W/K for all other anchors (worst case);
- n_{fix} = number of anchors per unit area [1/m²].

The influence of thermal bridges can also be calculated as described in EN ISO 10211. It shall be calculated according to this standard if there are more than 16 anchors per m² foreseen. The declared X_p values do not apply in this case.

ANNEX L – OTHER COMPONENTS TESTS

This annex establishes special test methods of components used for the verification of constancy of performance and for the characterization of the components.

L.1 Density of mortars

L.1.1 Product as delivered

Pastes and liquids:

This is measured at (23 ± 2) °C in a 1000 cm³ cylinder.

Powders:

This is measured at (23 ± 2) °C in a 500 cm³ cylinder.

Method of operation:

The results are recorded after maximum packing down on a vibrating table and levelling of the surface. The results are expressed in kg/m³ (mean value of 3 tests).

L.1.2 Fresh mortar

Preparation of mortar:

The mortar is prepared in the laboratory according to manufacturer's instructions.

In most cases, manufacturers shall specify both spray (large surfaces) and trowel (small surfaces) applied mortar. Therefore, unless the manufacturer specifies the method of application, or the more onerous application method can be determined, tests shall be conducted with both spray and trowel applied material and the density of both shall be measured. The ETA shall specify the densities and their tolerances for trowel and spray applied renderings.

Method of operation:

The apparent density is determined using a 1 litre cylindrical container, previously tared (mass M_0 in g). The container is filled with paste and after compacting down, wiped off and weighed (mass M_1 in g). The density of the paste (in kg/m³) is equal to $M_1 - M_0$. The density of the paste is measured immediately after mixing.

L.1.3 Hardened mortar

The specimens shall be prepared according to section L.1.2 using an adequate formwork or mould.

Apparent density of hardened mortar shall be determined by measuring mass and dimensions. The accuracy for weighing is 1/1000 and for the dimensions 1/100.

Alternative method according to EN 1015-10 can be used.

L.2 Particle size grading

Pastes:

Particle size grading is established from a sample of fillers removed from the manufactured product after washing on a sieve, mesh size 0,08 mm or after any other suitable and pertinent preparation. The test is carried out after drying at least at 105 °C.

Powders:

Particles size grading is established from a sample of fillers removed from the manufactured product.

Method of operation:

The test is performed using air stream sieving on an about 50 g specimen for 5 minutes per sieve. The curve is traced from 0,04 (for powders) or 0,08 (for pastes) to 4 mm with at least 5 intermediate sieves.

L.3 Dry extract (only pastes and liquids)

L.3.1 Lime and polymer based products

This is determined after placing the sample in a ventilated oven set at (105 ± 5) °C until a constant mass is obtained.

The mass is regarded as constant if the difference in mass between two successive weightings, one hour apart, does not exceed 0,1 g.

Initial weighing for testing:

- 2 g for liquid products (impression, etc ...),
- 5 g for products in paste form.

The results are expressed as a percentage relative to the initial mass (mean value of 3 tests).

Alternative method according to EN 480-8 can be used.

L.3.2 Silicate based products

The dry extract is determined by the following method:

A - Initial weighing of approximately 5 g (product in the as-delivered state) on an aluminium sheet, approximately 100 mm x 100 mm, 2/3 covered.

B - Pre dry for 1 hour at (125 ± 10) °C. Dry for 2 hours at (200 ± 10) °C.

C - Final weighing.

Weighing accuracy shall be within 5 mg.

The difference in mass from the initial weighing is accounted for by volatile components including water of crystallization.

The results are expressed as a percentage relative to the initial mass (mean value of 3 tests).

Alternative method according to EN 480-8 can be used.

L.4 Ash content

L.4.1 Base coat, adhesives and grout

Pastes and liquids:

The ash content is determined on the same samples as those on which the dry extract has been measured.

Powders:

The ash content is determined at 450°C and 900°C on a sample of approximately 5 g pre-dried at (100 ± 5) °C or at (200 ± 5) °C for silicate based products, to constant mass. The mass is regarded as constant if the difference in mass between two successive weightings, one hour apart, does not exceed 0,1 g.

Method of operation:

- The sample is placed in a tared crucible either fitted with a lid or enclosed in a leak-tight container and the whole is weighed,
- After the lid has been removed, where necessary, the crucible is placed in the oven maintained at ambient temperature,
- The temperature of the oven is then raised to (450 ± 20) °C (ash content at 450 °C) or to (900 ± 20) °C (ash content at 900 °C) and maintained at that temperature for 5 hours,
- The crucible is allowed to cool down to room temperature in the desiccators before being weighed.

The results are expressed as a percentage relative to the initial mass after drying (mean value of 3 tests).

Note: The tolerances at 900 °C may become larger, taking account of the products' composition.

L.4.2 Glass fibre reinforcement mesh

The ash content is determined at (625 ± 20) °C on three 100 mm square samples, cut parallel to the yarn and at least 100 mm apart from the side to constant mass.

The result is expressed as a percentage relative to the initial mass.

L.5 Modulus of elasticity, tensile strength and elongation

L.5.1 Products with a thickness greater than 5 mm

Preparation and storing of test samples:

The mortar is prepared by mixing as described in section L.1.2.

Test samples, conforming to the dimensions defined in the paragraphs below, are prepared in metal moulds in two layers.

Each layer is compacted into position by dropping alternately each side of the mould from a height of 5 mm approximately ten times. The test samples are then levelled with a metal ruler.

The test samples are removed from the mould after 24 h.

They are then stored for at least 28 days at (23 ± 2) °C and (50 ± 5) % relative humidity.

Dynamic modulus of elasticity (Resonance frequency method)

The dynamic modulus of elasticity is determined on prismatic test samples measuring 25 mm x 25 mm x 285 mm.

The test is carried out on 3 samples prepared as described above.

The individual values of the apparent density (in kg/m³) and the modulus (in MPa) of the 3 test samples and the mean value of the results obtained are noted.

The principle of the measurement consists of measuring the basic resonance frequency of a test sample under longitudinal vibration.

1 – Apparatus:

The apparatus used for carrying out this measurement comprises:

- a) A variable frequency oscillator, with a frequency range of 20 kHz and an accuracy of 1%.
- b) An electromagnetic vibrator which may or may not be in mechanical contact with the test sample; its mass shall be very light compared to that of the test sample.
- c) A receiver, an electromechanical transducer and an amplifier; its mass shall be very light compared to that of the test sample.

The resonance frequencies of the vibrator and the receiver shall not fall between 0,5 kHz and 20 kHz.

- d) An amplifier.
- e) An apparatus indicating the vibration amplitudes (voltmeter, milliammeter, oscilloscope).
- f) A very narrow support on which the test sample rests during the measurement, which shall not hinder the longitudinal vibration of the test sample and which shall be in the nodal plane.

2 - Testing

The sample is centred on the support. The vibrator and the receiver are placed as shown in the figure below:

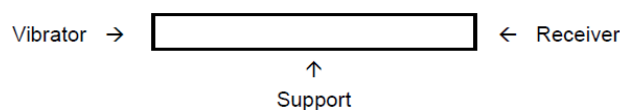

It is important that the ends of the test piece are free to vibrate in an axial direction. The vibration generator and the receiver, if they are in contact with the test piece, should exert an equal very weak stress on the two ends. In this case, it is recommended to weakly bond the mobile part of the vibrator to the sample using a coupling product (mastic). The same applies for the receiver.

The variable frequency oscillator supplies the vibrator and the test piece vibrates longitudinally. The vibrations are collected by the receiver and after amplification their amplitude is shown on a dial (voltmeter, milliammeter, oscilloscope). For most frequency ranges, the vibration amplitude is quite small. But for certain frequencies, the displacement becomes appreciable. The resonance conditions are created when maximum amplitude is obtained on the indicating dial.

The frequency of the basic longitudinal resonance corresponds to the lowest frequency for which a maximum amplitude is obtained (for the higher harmonic frequencies a resonance is also produced).

Two measurements are carried out: the vibration is produced successively at the two ends of the test piece. The mean value is recorded. If the difference between the two values is higher than 5 % the vibrations are restarted.

The measurements of the mass and dimensions of the test piece are needed to calculate the modulus. The accuracy for weighing is 1/1000 and for the dimensions is 1/100.

3 - Expressing the results:

As the basic longitudinal resonance frequency, the mass and the dimensions of the test piece are known the dynamic modulus of elasticity is determined using the following formula:

$$E_d = 4L^2 * F^2 * \rho * 10^{-6}$$

E_d = Longitudinal dynamic modulus of elasticity in Newton per square millimetre.

L = Length of test piece in metres.

F = Longitudinal resonance frequency in Hertz.

ρ = Mass per unit volume in kg/m^3 .

L.5.2 Products with a thickness up to 5 mm

Preparation and storing of test samples:

The mortar is prepared by mixing as described in section L.1.2.

The tests are performed on test samples measuring 3 mm x 50 mm x 300 mm.

Moulds for the samples are made using appropriately positioned 3 mm thick strips of extruded polystyrene adhered to expanded polystyrene boards.

After the mortar (without reinforcement) has dried, test samples are cut from the polystyrene with hot wire.

Static modulus of elasticity, tensile strength and elongation at break

The test sample is subjected to a tensile test until it breaks using a suitable machine which records the tensile stress and elongation. The distance between the jaws of the machine is 200 mm. The sample is held between the jaws with the interposition of pads.

The tensioning speed is 2 mm/minute.

The tests are carried out on five samples stored for at least 28 days at $(23 \pm 2) ^\circ\text{C}$ and $(50 \pm 5) \% \text{RH}$ and on five samples which have undergone the hygrothermal test (placed in the window of the specimen).

L.6 Shrinkage

The measurement is carried out on three samples of base coat measuring 20 mm x 40 mm x 160 mm prepared and stored as described in section L.1.2, by inserting measuring spindles in the front end (10 mm x 40 mm) of the samples.

Measurements are carried out at regular intervals. The value after 28 days is recorded. In addition if there is doubt in the curve associated with stabilisation, the test is continued and the value after 56 days is recorded.

Alternative method according to EN 12617-4 or EN 12808-4 can be used.

L.7 Mass per unit area of reinforcement mesh

The mass per unit area is determined by measuring and weighting a one metre length of mesh.

For reinforcement in roll form, the width of the sample should be the same as the roll width.

The result is expressed in g/m^2 .

L.8 Mesh size and number of filaments

The mesh size is determined by measuring the distance between 21 yarns (e.g. 20 mesh) in warp and in weft direction.

The mesh opening is calculated by subtracting the thickness of the yarn from the mesh size.

L.9 Tensile strength and elongation of reinforcement mesh

Tensile strength and elongation of the reinforcement mesh is determined according to EN 13496 in the following conditions:

- As-delivered state: after conditioning the samples at (23 ± 2) °C and (50 ± 5) % RH for at least 24 hours.
- After ageing: after immersion the samples for 28 days in the alkaline solution at (23 ± 2) °C. 20 samples (10 in the weft and 10 in the warp direction) in 4 litres solution.