

EUROPEAN ASSESSMENT DOCUMENT

EAD 340002-00-0204

February 2016

PANELS OF STEEL WIRES WITH INCORPORATED THERMAL INSULTATION FOR A WHOLE STRUCTURE

The reference title and language for this EAD is English. The applicable rules of copyright refer to the document elaborated in and published by EOTA.

This European Assessment Document (EAD) has been developed taking into account up-to-date technical and scientific knowledge at the time of issue and is published in accordance with the relevant provisions of Regulation (EU) No 305/2011 as a basis for the preparation and issuing of European Technical Assessments (ETA).

Contents

1	SCOPE OF THE EAD	6
1.1	Description of the construction product	6
1.1.1	General description of the kit.....	6
1.1.2	Panels of welded fabric and a core of thermal insulation material of expanded polystyrene, EPS.....	7
1.1.3	Shotcrete.....	8
1.1.4	Further product related aspects.....	8
1.2	Information on the intended use of the construction product	9
1.2.1	Intended use(s)	9
1.2.2	Working life/Durability.....	9
1.3	Specific terms used in this EAD	9
1.3.1	Panel.....	9
1.3.2	Connector	10
1.3.3	Core	10
2	ESSENTIAL CHARACTERISTICS AND RELEVANT ASSESSMENT METHODS AND CRITERIA	10
2.1	Essential characteristics of the product	10
2.2	Methods and criteria for assessing the performance of the product in relation to essential characteristics of the product	13
	Essential characteristics of the assembled system	13
2.2.1	Shape of panels	13
2.2.2	Dimensions of panels.....	13
2.2.3	Resistance to flexure.....	13
2.2.4	Resistance to shear.....	14
2.2.5	Resistance to compression	14
2.2.6	Resistance to concentrated loads.....	14
2.2.7	Long term loading	14
2.2.8	Resistance to seismic actions	15
2.2.9	Resistance to corrosion.....	23
2.2.10	Reaction to fire	23
2.2.11	Resistance to fire	23
2.2.12	Vapour permeability	23
2.2.13	Airborne sound insulation.....	24
2.2.14	Thermal resistance.....	24

2.2.15	Thermal inertia	24
2.2.16	Air tightness	24
Essential characteristics of the welded fabric		24
2.2.17	Mechanical characteristics	24
2.2.18	Weld shear force	24
2.2.19	Bending.....	25
2.2.20	Dimensions	25
2.2.21	Mass	25
2.2.22	Resistance to corrosion.....	25
2.2.23	Reaction to fire	25
Essential characteristics of the connectors of stainless steel		25
2.2.24	Mechanical characteristics	25
2.2.25	Weld shear force	25
2.2.26	Dimensions	26
2.2.27	Mass	26
2.2.28	Resistance to corrosion.....	26
2.2.29	Reaction to fire	26
2.2.30	Thermal conductivity	26
2.2.31	Specific heat capacity.....	26
Essential characteristics of the thermal insulation material of expanded polystyrene, EPS		26
2.2.32	Dimensional stability.....	26
2.2.33	Compressive creep	26
2.2.34	Compressive stress at 10 % deformation	26
2.2.35	Shear behaviour	26
2.2.36	Reaction to fire	27
2.2.37	Water vapour transmission.....	27
2.2.38	Apparent density	27
2.2.39	Bending strength	27
2.2.40	Shape.....	27
2.2.41	Dimensions	27
2.2.42	Squareness.....	27
2.2.43	Thermal conductivity	27
3	ASSESSMENT AND VERIFICATION OF CONSTANCY OF PERFORMANCE	28
3.1	System(s) of assessment and verification of constancy of performance to be applied.....	28
3.2	Tasks of the manufacturer	28
3.3	Tasks of the notified body.....	30

4	REFERENCE DOCUMENTS	33
ANNEX 1	- DETAILS FOR CHARACTERISATION	35
ANNEX 2	- COMPONENTS OF THE KIT	36
ANNEX 3	- NUMBER OF SPECIMENS	38
ANNEX 4	- SPECIMENS	39

1 SCOPE OF THE EAD

1.1 Description of the construction product

1.1.1 General description of the kit

The product, "Panels of steel wires with incorporated thermal insulation for a whole structure", is a panel of a 3-dimensional grid of steel wires and incorporated thermal insulation material and is comprised of

- Panels, see Figure 1, made of
 - A 3-dimensional grid of two welded fabrics of steel wires, jointed with connectors of stainless steel wire welded to the fabrics;
 - Thermal insulation material of expanded polystyrene, EPS, between the two welded fabrics, penetrated by the connectors.

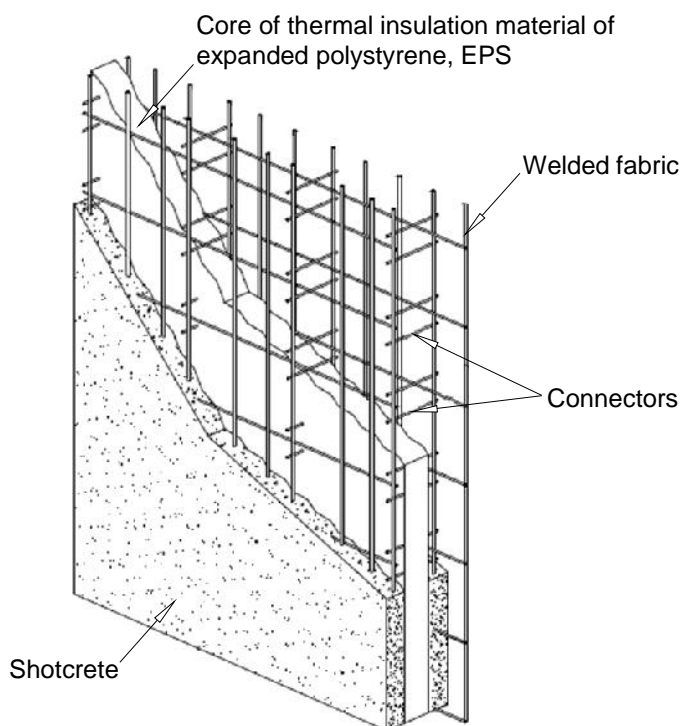

Figure 1 Panel – Factory made 3-dimensional grid of steel wires and a core of thermal insulation material of expanded polystyrene, EPS.

- Stair panels, see Figure 2, made of
 - A 3-dimensional grid of two welded fabrics of steel wires, jointed with connectors of stainless steel wire welded to the fabrics. The welded fabrics are bent to the shape of the stair.
 - Thermal insulation material of expanded polystyrene, EPS, between the two welded fabrics, penetrated by the connectors. The EPS is cut to the shape of the stair.
 - The longitudinal cavities of the stair panels are reinforced and concreted according to the design. Reinforcing steel and concrete and are not part of the kit.

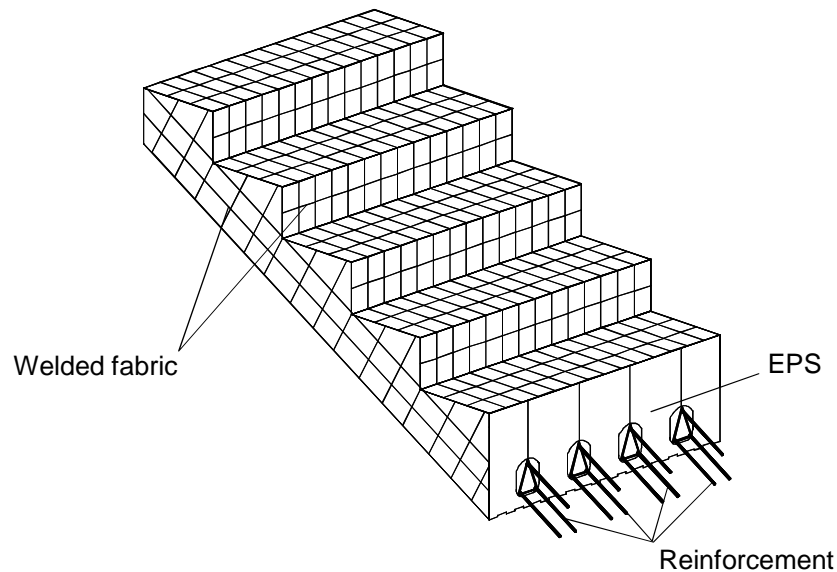

Figure 2 Stair panel – Factory made 3-dimensional grid of steel wires and a core of thermal insulation material of expanded polystyrene, EPS.

- Strips and sheets of welded fabric of steel wires to be tied on the panels to reinforce joints, corners and the edges of openings e.g. cut outs for windows, etc., see Annex 2, Figure 14.

1.1.2 Panels of welded fabric and a core of thermal insulation material of expanded polystyrene, EPS

The welded fabric is made of galvanised steel wires and the connectors of stainless steel. Yield strength of wires for welded fabric and connectors of stainless steel is about 600 MPa.

For a building the walls are split up into panels, see an example in Annex 2, Figure 13, taking into account all the particularities such as doors and windows, reinforcement, etc.. The panels are manufactured in standardised widths, in general 112 cm. The length of the panels is specific to the project. On site the panels are arranged next to each other, similar as shown in Annex 2, Figure 13, on a substructure flat and carefully levelled out before placing the panels. In the substructure e.g. splice bars are installed for structural connection of the panels. Care should be taken to tightly close the joints between the cores of expanded polystyrene without remaining gap between them. In addition, the panels are aligned vertically with flush cores of expanded polystyrene. All that to ensure equal thickness of shotcrete over the whole wall and to avoid thermal bridges within the wall.

The installed panels are completed with the following additional components.

- Additional reinforcing steel can be tied to the welded fabric to enhance the structural performance of the structure. This applies in particular to reinforcement of lintels, parapets, and ring anchors at the floor level. The additional reinforcement is not part of the kit.
- E.g. connections, corners of windows and doors, etc. are reinforced with strips and sheets of welded fabric that are part of the kit.
 - Angular strips

All the building internal and external corners, either vertical or horizontal, are reinforced with angular welded fabrics that are attached to the welded fabric of the panels, see Annex 2, Figure 14.

- Sheets
All openings are reinforced at both sides by placing a flat sheet of welded fabric with an inclination of 45 ° on each corner, see Annex 2, Figure 14. The window and door lintels, according to their length and the window parapets are additionally reinforced from both sides. However, these additionally reinforcement is not part of the kit.
- U-shaped strips
Along the reveals of door and window openings and along the edges of walls U-shaped welded fabrics or, as an alternative, double angular strips are placed with sealing panel, see Annex 2, Figure 14.
- Concrete is applied on both sides of the elements with the shotcrete technique, covering the welded fabrics and, if applicable, the additional reinforcing steel. Shotcrete is not part of the kit.
- External finish – non-structural component, not part of the kit
- Internal finish – non-structural component, not part of the kit
- Auxiliary devices to fix partitions, windows and doors, etc., non-structural components, not part of the kit
- A common floor system of reinforced concrete. The floor system of reinforced concrete is not part of the kit.
- Reinforcing steel and concrete for the stair panels. Reinforcing steel and concrete are not part of the kit.

The final structure is a 'sandwich' of two layers of concrete, reinforced with the welded fabrics and, if applicable, the additional reinforcing steel, and a core of thermal insulating material, see Figure 1, Figure 2, and Annex 2, Figure 11 for further details.

1.1.3 Shotcrete

Shotcrete is provided on the construction site. The shotcrete conforms to EN 14487-1 and is applied according to EN 14487-2. The Shotcrete is not part of the kit.

Load bearing walls are completed by applying shotcrete on both sides of the panels with a thickness of at least 3.5 cm. Thereby appropriate concrete cover is ensured. The structure thus obtained is a reinforced concrete member with a core of expanded polystyrene, EPS.

The shotcrete is according to the design of the structure and appropriate for the exposure class the structure is subject to. At least the following specifications are met.

- Concrete strength class at least C25/30
- Exposure class at least XC1
- Maximum aggregate size should be 6 mm
- Without fibre reinforcement

1.1.4 Further product related aspects

The product is not covered by a harmonised European standard.

Concerning product packaging, transport, storage, maintenance, replacement and repair it is the responsibility of the manufacturer to undertake the appropriate measures and to advise his clients on transport, storage, maintenance, replacement and repair of the product as he considers necessary.

It is assumed that the product will be installed according to the manufacturer's instructions or (in absence of such instructions) according to the usual practice of the building professionals.

Relevant manufacturer's stipulations having influence on the performance of the product covered by this European Assessment Document shall be considered for the determination of the performance and detailed in the ETA.

1.2 Information on the intended use of the construction product

1.2.1 Intended use(s)

The intended use of the "Panels of steel wires with incorporated thermal insulation for a whole structure" is the construction of structures, typically for buildings, including internal and external walls, which may be above or below ground, stairs, roofs and their joints. The structure is completed on site with reinforcing steel, if required, and with shotcrete. Reinforcing steel and shotcrete have both a structural function within the structure but are not part of the kit.

The structure constructed with the panels is subjected to only static, quasi-static, and seismic actions.

The kit is intended to be used as a structural part of dissipative structures in seismic areas.

Included are structures subject to fire regulation.

1.2.2 Working life/Durability

The assessment methods included or referred to in this EAD have been written based on the manufacturer's request to take into account a working life of the "Panels of steel wires with incorporated thermal insulation for a whole structure" for the intended use of 50 years when installed in the works, provided that the "Panels of steel wires with incorporated thermal insulation for a whole structure" are subject to appropriate installation, see Clause 1.1. These provisions are based upon the current state of the art and the available knowledge and experience.

When assessing the product the intended use as defined by the manufacturer shall be taken into account. The real working life may be, in normal use conditions, considerably longer without major degradation affecting the basic requirements for construction works¹.

The indications given as to the working life of the construction product cannot be interpreted as a guarantee neither given by the product manufacturer or his representative nor by EOTA when drafting this EAD nor by the Technical Assessment Body issuing an ETA based on the EAD, but are regarded only as a means for expressing the expected economically reasonable working life of the product.

1.3 Specific terms used in this EAD

1.3.1 Panel

Panel is the factory made product, see Figure 11, which comprises

- Two welded fabric of steel wires;
- Connectors of stainless steel that are welded to the welded fabrics at the points of intersection to join the two welded fabrics;
- Core of expanded polystyrene, EPS, penetrated by the connectors of stainless steel.

¹ The real working life of a product incorporated in a specific works depends on the environmental conditions to which that works is subject, as well as on the particular conditions of design, execution, use and maintenance of that works. Therefore, it cannot be excluded, that in certain cases the real working life of the product may also be shorter than referred to above.

1.3.2 Connector

The connector is a component of the panel and is made of stainless steel wires. The connector is factory welded to the two welded fabrics of the panel to join them.

1.3.3 Core

The core is a component of the panel and is made of expanded polystyrene, EPS. The core is placed in the panel during manufacturing in the factory. The core is penetrated by the connectors of stainless steel.

2 ESSENTIAL CHARACTERISTICS AND RELEVANT ASSESSMENT METHODS AND CRITERIA

2.1 Essential characteristics of the product

Table 1, Table 2, Table 3, and Table 4 show how the performance of "Panels of steel wires with incorporated thermal insulation for a whole structure" is assessed in relation to the essential characteristics.

Table 1 Essential characteristics of the product and methods and criteria for assessing the performance of the product in relation to those essential characteristics

No	Essential characteristic	Assessment Method	Type of expression of product performance, level, class, or description
Basic requirement for construction works 1: Mechanical resistance and stability			
1	Shape of panels	2.2.1	Description
2	Dimensions of panels	2.2.2	Description
3	Resistance to flexure	2.2.3	Description
4	Resistance to shear	2.2.4	Description
5	Resistance to compression	2.2.5	Description
6	Resistance to concentrated loads	2.2.6	Description
7	Long term loading	2.2.7	Description
8	Resistance to seismic actions	2.2.8	Description
9	Resistance to corrosion	2.2.9	Description
Basic requirement for construction works 2: Safety in case of fire			
10	Reaction to fire	2.2.10	Class
11	Resistance to fire	2.2.11	Description
12	Vapour permeability	2.2.13	Description

No	Essential characteristic	Assessment Method	Type of expression of product performance, level, class, or description
Basic requirement for construction works 4: Safety and accessibility in use			
13	Same as basic requirement 1, except resistance to seismic actions (No 8).		
Basic requirement for construction works 5: Protection against noise			
14	Airborne sound insulation	2.2.14	Level
Basic requirement for construction works 6: Energy economy and heat retention			
15	Thermal resistance	2.2.15	Level
16	Thermal inertia	2.2.16	Level
17	Air tightness	2.2.17	Level

Table 2 Essential characteristics of the welded fabric and methods and criteria for assessing the performance of the product in relation to those essential characteristics

No	Essential characteristic	Assessment Method	Type of expression of product performance, level, class, or description
Basic requirement for construction works 1: Mechanical resistance and stability			
1	Mechanical characteristics	2.2.18	Level
2	Weld shear force	2.2.19	Level
3	Bending	2.2.20	Description
4	Dimensions	2.2.21	Level
5	Mass	2.2.22	Level
6	Resistance to corrosion	2.2.23	Description
Basic requirement for construction works 2: Safety in case of fire			
7	Reaction to fire	2.2.24	Class
Basic requirement for construction works 4: Safety and accessibility in use			
8	Same as basic requirement 1	—	—

Table 3 Essential characteristics of the connectors of stainless steel and methods and criteria for assessing the performance of the product in relation to those essential characteristics

No	Essential characteristic	Assessment Method	Type of expression of product performance, level, class, or description
Basic requirement for construction works 1: Mechanical resistance and stability			
1	Mechanical characteristics	2.2.25	Level
2	Weld shear force	2.2.26	Level
3	Dimensions	2.2.27	Level
4	Mass	2.2.28	Level
5	Resistance to corrosion	2.2.29	Description
Basic requirement for construction works 2: Safety in case of fire			
6	Reaction to fire	2.2.30	Class
Basic requirement for construction works 4: Safety and accessibility in use			
7	Same as basic requirement 1	—	—
Basic requirement for construction works 6: Energy economy and heat retention			
8	Thermal conductivity	2.2.31	Level
9	Thermal inertia	2.2.32	Level

Table 4 Essential characteristics of the thermal insulation material of expanded polystyrene, EPS, and methods and criteria for assessing the performance of the product in relation to those essential characteristics

No	Essential characteristic	Assessment Method	Type of expression of product performance, level, class, or description
Basic requirement for construction works 1: Mechanical resistance and stability			
1	Dimensional stability	2.2.33	Description
2	Compressive creep	2.2.34	Level
3	Compressive stress at 10 % deformation	2.2.35	Level
4	Shear behaviour	2.2.36	Level
Basic requirement for construction works 2: Safety in case of fire			
5	Reaction to fire	2.2.37	Class

No	Essential characteristic	Assessment Method	Type of expression of product performance, level, class, or description
Basic requirement for construction works 3: Hygiene, health, and the environment			
6	Water vapour transmission	2.2.38	Level
Basic requirement for construction works 4: Safety and accessibility in use			
7	Same as basic requirement 1	—	—
Basic requirement for construction works 6: Energy economy and heat retention			
8	Apparent density	2.2.39	Level
9	Bending strength	2.2.40	Level
10	Shape	2.2.41	Description
11	Dimensions	2.2.42	Description
12	Squareness	2.2.43	Description
13	Thermal conductivity	2.2.44	Level

2.2 Methods and criteria for assessing the performance of the product in relation to essential characteristics of the product

Characterisation of products to be assessed shall be done in accordance with available specifications, notably as given in Annex 1.

Essential characteristics of the assembled system

2.2.1 Shape of panels

The shape of a panel of steel wires with incorporated thermal insulation is determined by visual inspection by reference to workshop drawings. The shape of the panels is given in representations like outline drawings.

2.2.2 Dimensions of panels

Dimensions of panels of steel wires with incorporated thermal insulation are measured. The dimensions shall conform to the panel specification.

2.2.3 Resistance to flexure

Subject of verification is the panel with applied shotcrete. Relevant loading conditions are flexural moments with vector of momentum out of plane of the panel.

Combined shear and compression tests are performed according to Clause 2.2.8, procedure 3.

Relevant performances are

- Initial stiffness

- Load bearing capacity
- Displacement capacity

See Clause 2.2.8, Resistance to seismic actions, for details on the assessment procedures.

2.2.4 Resistance to shear

Subject of verification is the panel with applied shotcrete. Relevant loading conditions are

- shear in plane of the panel

Combined shear and compression tests are performed according to Clause 2.2.8, procedure 3.

Relevant performances are

- Initial stiffness
- Load bearing capacity
- Displacement capacity

See Clause 2.2.8, Resistance to seismic actions, for details on assessment procedures.

2.2.5 Resistance to compression

Subject of verification is the panel with applied shotcrete. Relevant loading conditions are

- Centric compression
- Eccentric compression
- Combined compression and flexure

Eccentric and centric compression tests are performed according to Clause 2.2.8, procedure 1, 2, and 3.

Relevant performances are

- Stiffness
- Load bearing capacity

See Clause 2.2.8, Resistance to seismic actions, for details on assessment procedures.

2.2.6 Resistance to concentrated loads

Subject of verification is the panel with applied shotcrete.

Concentrated loads can be applied to the shotcrete only. Anchors are installed in the shotcrete for fixing objects. For heavy objects the performance of the panels with shotcrete are unsuitable and solutions that are not subject of the EAD are implemented.

2.2.7 Long term loading

Subject of verification is the panel with applied shotcrete. The specimens are defined by

- panels in terms of steel and dimensions of welded fabric, connectors of stainless steel, expanded polystyrene, EPS, and overall dimensions
- shotcrete in terms of thickness, strength, and maximum aggregate size

Full scale experimental assessment are carried out using the test setup of Annex 4, Figure 15.

Relevant performances are

- Stiffness, considering long term deformation.

2.2.8 Resistance to seismic actions

Subject of verification are panels and assemblies of panels with applied shotcrete. The specimens are defined by

- Panels in terms of steel and dimensions of welded fabric, connectors of stainless steel, expanded polystyrene, EPS, and overall dimensions
- Shotcrete in terms of thickness, strength, and maximum aggregate size

The following procedures are applied, see also Annex 3 for further details.

- Procedure 1

Quasi-static monotonic tests are performed on small sized specimens, see Annex 4, Figure 16, to identify the mechanical properties

- Centred compression

Axial load, uniformly distributed on the cross-section, see Annex 4, Figure 16 a).

Object of the test is to compare the compressive strength of the panel with shotcrete and the compressive strength of cylindrical shotcrete specimens to identify the confinement effect to be adopted in shear and flexural resistance models.

Initial stiffness is also defined and the cross-sectional area to be considered in the elastic model is calculated.

Plot axial load vs axial deformation curve, Figure 3.

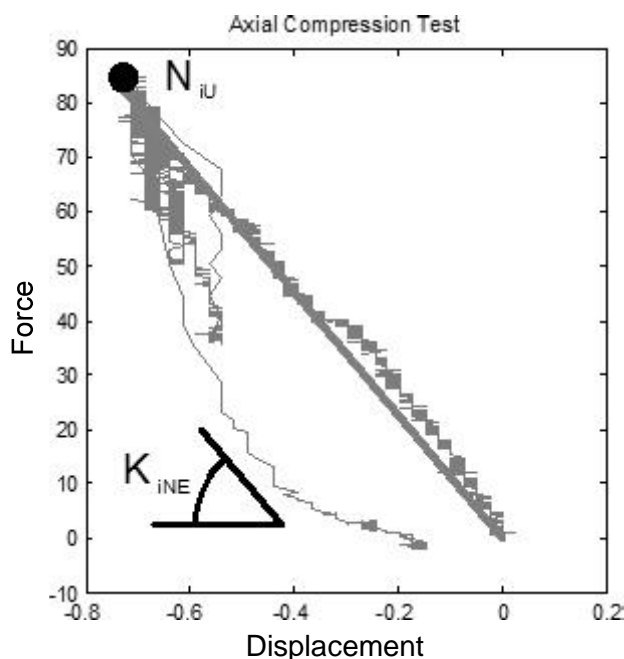

Figure 3 Parameter in compression test – Example

- Initial in-plane stiffness, K_{iNE} in kN/m
- Ultimate load, N_{iU} in kN
- Eccentric axial compression

Axial load applied in the plane of one shotcrete layer, see Annex 4, Figure 16 b).

Object of this test is to determine the compression strength of a single layer to define the resistance to be considered in the application where a single portion of the panel with applied shotcrete is loaded. Local buckling effects are also investigated.

Plot axial load vs deformation curve.

- Ultimate load, N_{iu} in kN

- Diagonal compression

Compression force applied along one diagonal of the panel with applied shotcrete, see Annex 4, Figure 16 c).

Object of the test is to determine the resistance to traction of the panel to be adopted in the shear and flexural resistance models.

Plot diagonal load vs deformation curve, Figure 4.

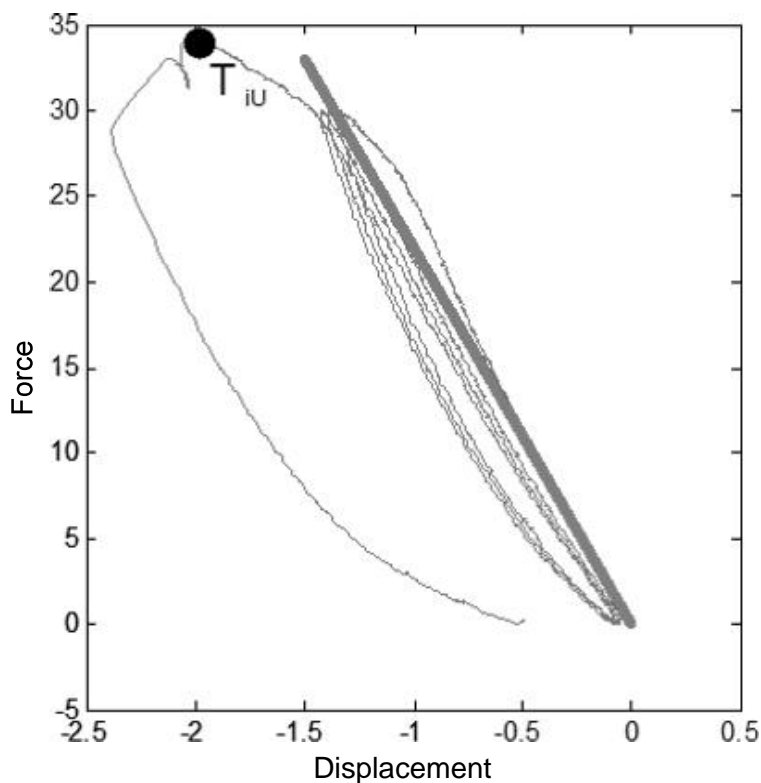

Figure 4 Parameter in diagonal compression test – Example

- Ultimate load, T_{iu} in kN

- Laminar shear

In-plane shear force applied to panels with shotcrete, see Annex 4, Figure 16 d).

Object of the test is to determine the coupling effect of connectors of stainless steel and expanded polystyrene, EPS, core when shear forces are applied in the plan of the panel. Coupling effect is determined throughout stiffness.

Plot shear load vs axial sliding deformation curve, Figure 5.

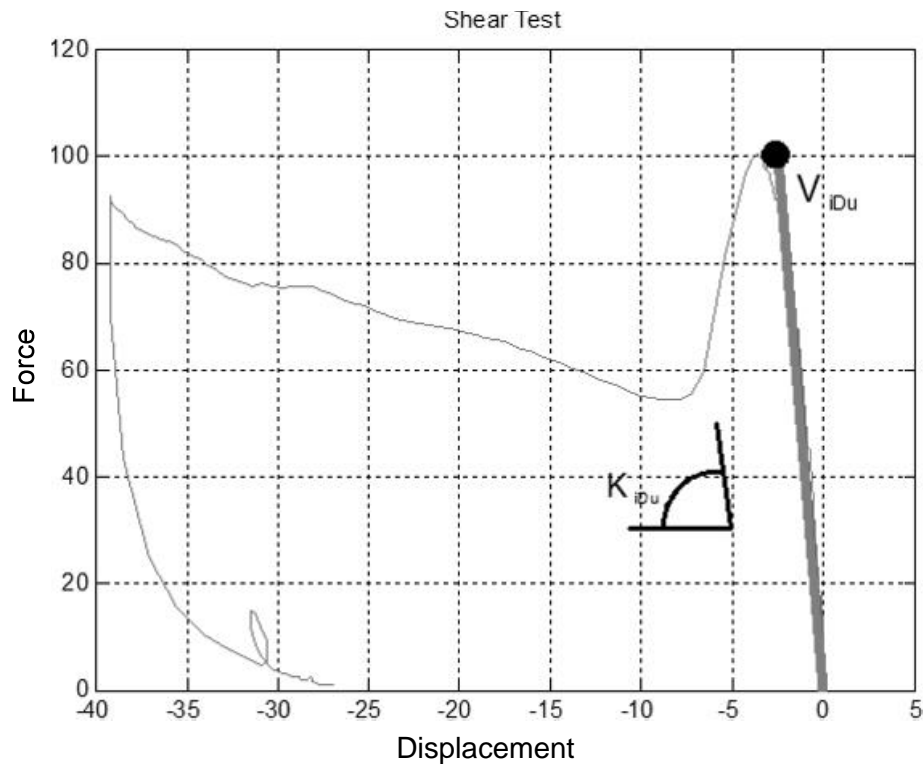

Figure 5 Parameter in shear test – Example

- Initial in-plane stiffness, K_{iDe} in kN/m
- Procedure 2
 Quasi-static monotonic tests are performed to study the buckling effects on the global response of panels with shotcrete, see Annex 3 and Annex 4, Figure 17.
 Object of the test is the definition of the limit of load in relation to the global instability, application of EC2 procedure to determine the load limit is adopted to derive the value of the moment of inertia fitting the experimental results.

Plot axial load vs axial deformation curve, Figure 6.

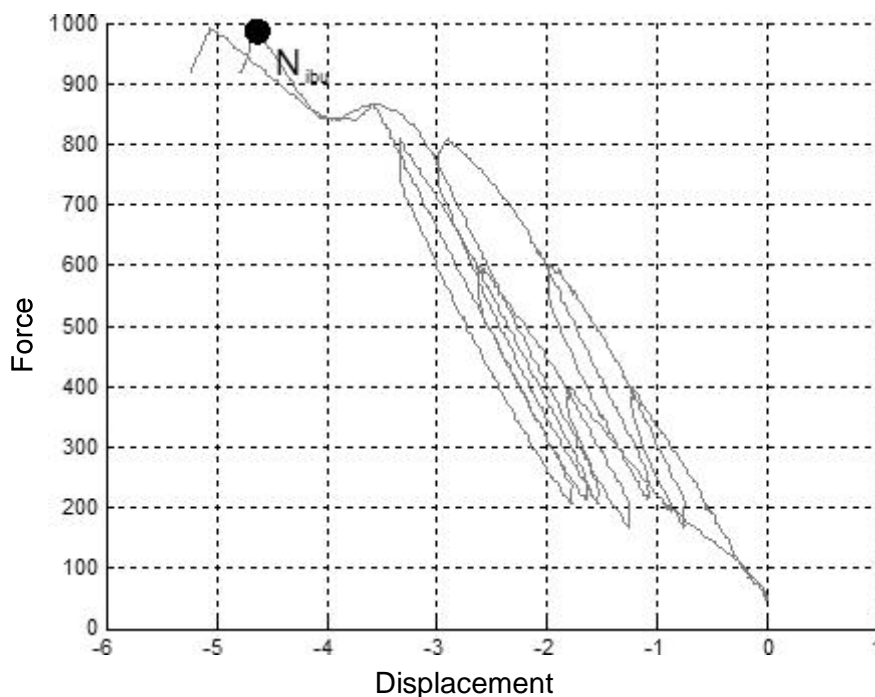

Figure 6 Parameter in compression test – Example

- Compression buckling strength, N_{ibu} in kN
- Procedure 3
 - Quasi-static cyclic tests on full scale panels, i.e. size and aspect ratios as normally used in construction works, are performed, considering the influence of openings, e.g. windows, doors or combinations thereof, see Annex 3 and Annex 4, Figure 18.
 - The tests should also take into account the boundary conditions of the members and the variation of the axial load during the seismic actions.
 - Plot base shear vs in-plane displacement curve, Figure 7 and Figure 8.
 - Initial stiffness of the panel with applied shotcrete, K_{iv_e} in kN/m
 - Load (shear) corresponding to the first deviation from the pure linear response, cracking, V_{icr} in kN
 - Load (shear) level corresponding to the yielding of the flexural (i.e. vertical) steel, V_{ie} in kN
 - Load (shear) level corresponding to the maximum resistance of the panel with applied shotcrete, V_{iu} in kN
 - Stability of the load obtained in each step of loading in term of decrement of V_{iu} during cycles
 - Maximum displacement obtained at cracking, d_{icr}
 - Maximum displacement obtained at yielding, d_{ie}
 - Maximum displacement obtained at collapse, d_{iu}

- Identification of the energy dissipated during each cycle, the average on three cycles and the corresponding equivalent damping.

The previous parameters should be determined for at least two level of vertical compression of the panel with applied shotcrete, two specimens should be tested, one per each vertical load level.

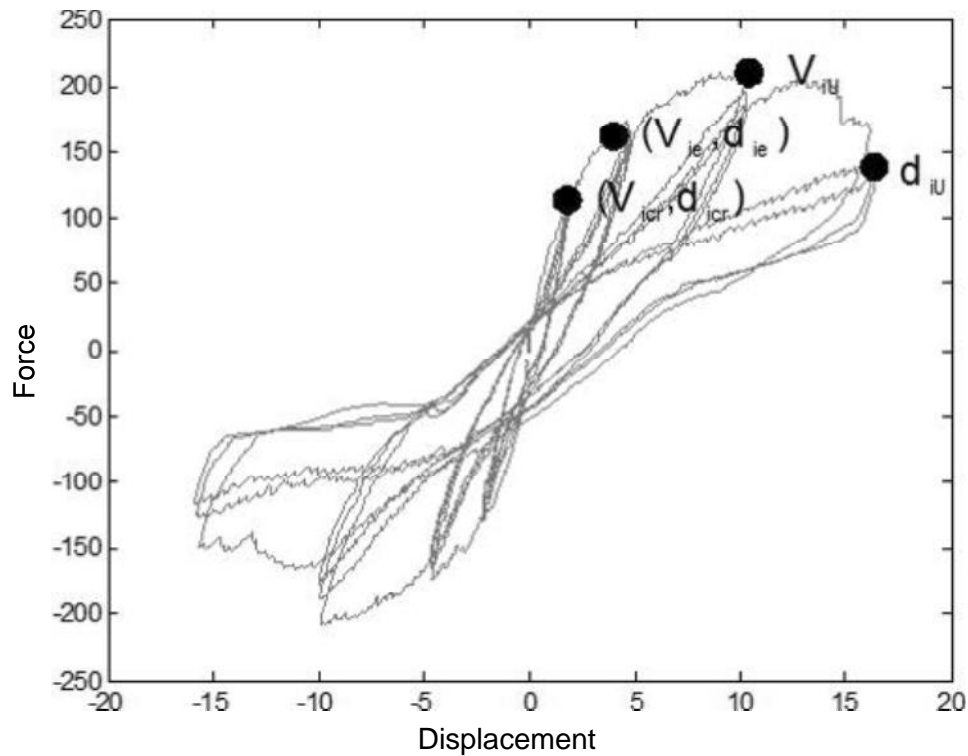

Figure 7 Parameters in lateral load test – Example

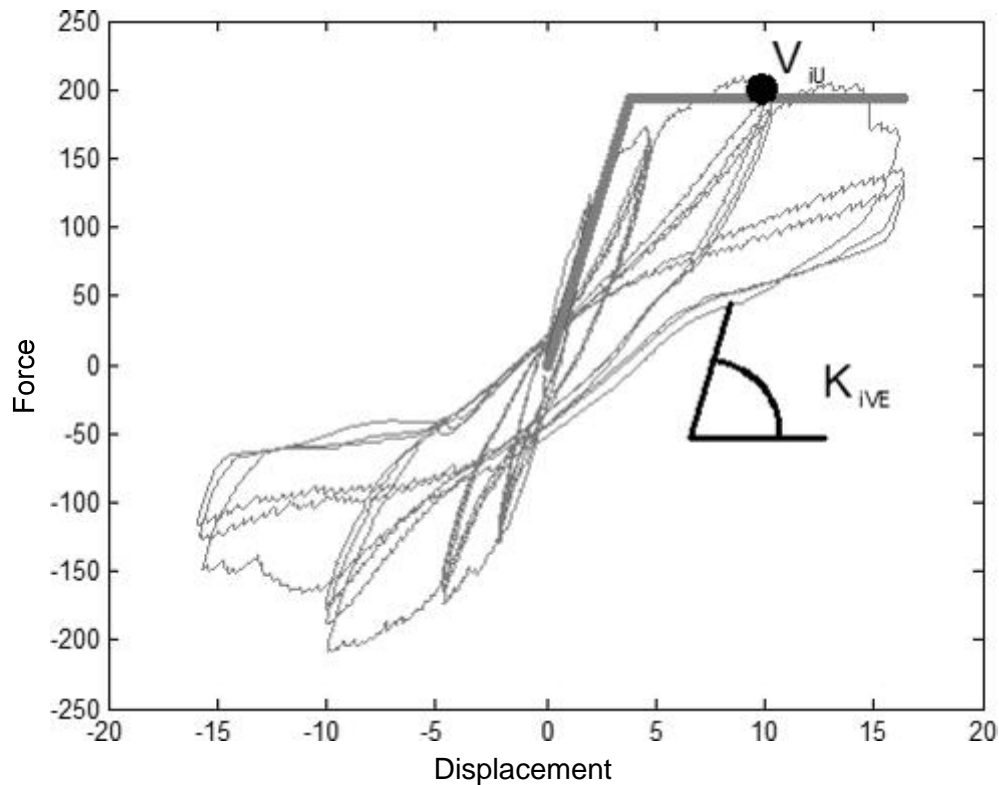

Figure 8 Parameter in shear test – Example

– Procedure 4

Quasi-static cyclic tests on connections, i.e. structural joints between members are performed on wall-to-wall, vertical joint, and wall-to-floor, horizontal joint, see Annex 3 and Annex 4, Figure 19.

The object of the test is the identification of the connection strength to be used in the definition of the analytical model.

Plot bending moment vs rotation curve, Figure 9, Figure 10.

- Initial stiffness of the panel with applied shotcrete, K_{ime} in kNm/rad
- Bending moment corresponding to the first deviation from the pure linear response (cracking), M_{icr} in kNm
- Bending moment corresponding to the yielding of the longitudinal steel, M_{ie} in kNm
- Bending moment corresponding to the maximum resistance of the panel with applied shotcrete, M_{iu} in kNm
- Stability of the load obtained in each step of loading in term of decrement of M_{iu} during cycles
- Maximum displacement obtained at cracking, ϑ_{icr}
- Maximum displacement obtained at yielding, ϑ_{ie}
- Maximum displacement obtained at collapse, ϑ_{iu}
- Identification of the energy dissipated during each cycle, the average on three cycles and the corresponding equivalent damping.

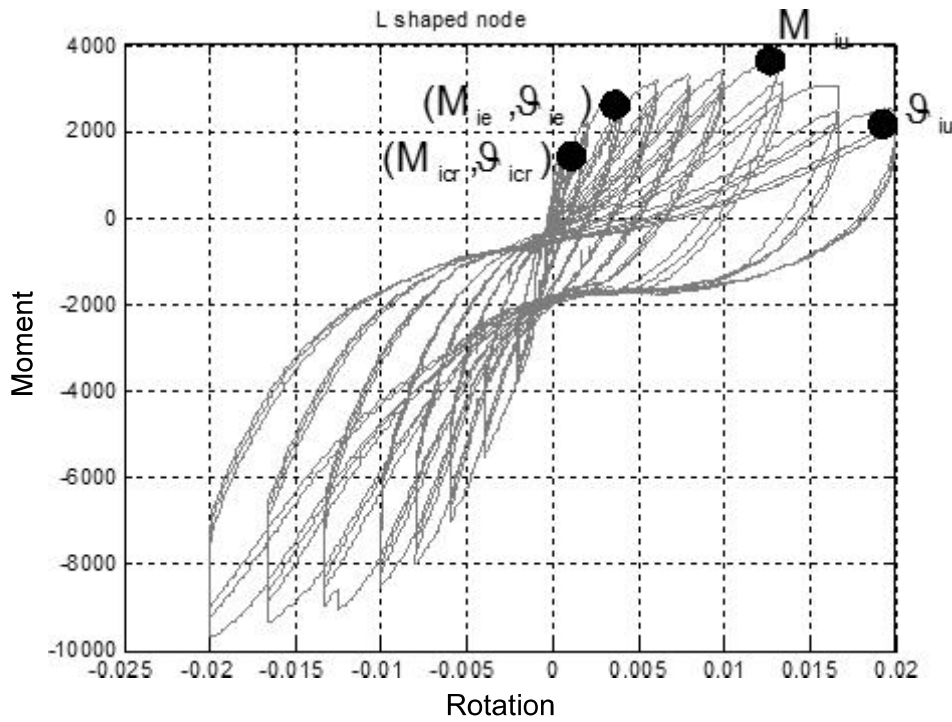

Figure 9 Parameter in connection test – Example

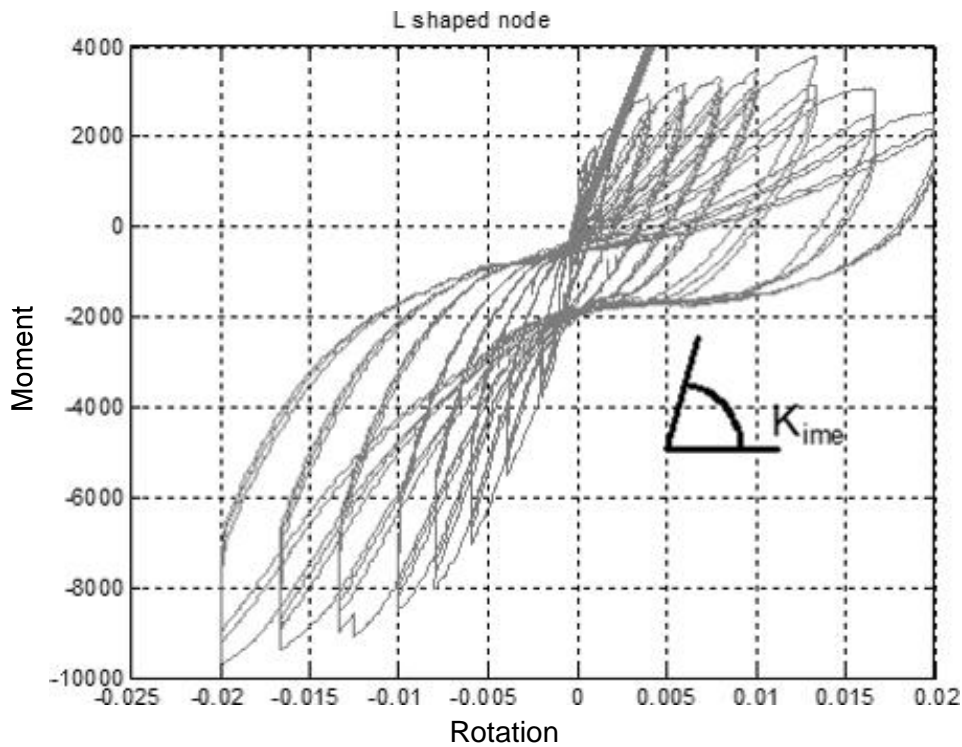

Figure 10 Parameter in connection test – Example

- Procedure 5
 Static monotonic bending tests on slab panels, simply supported, with at least two different distances between load and support are considered, see Annex 4, Figure 20. For cores of expanded polystyrene with different thickness.

The object of the test is to define the initial stiffness of the panel and the moment of inertia of the section to be adopted when considering the short term loads.

Each test is performed on an adequate number of specimens. The minimum numbers are indicated in Annex 3. Adequate numerical analyses is provided to validate the experimental results (linear and/or non-linear models accounting for correct deformation contributions) and to determine the parameter required in the design procedure.

Test specimens used in the assessment procedure will be increased if the results of the experimental assessment will be excessively disperse.

Test are performed until the collapse of the specimen, such condition is conventionally assumed in a decrease of 20 % of the maximum value observed during the test.

Test description

The test required to assess the system performance is conducted in pseudo-static regime, i.e. inertia forces are negligible.

Test on small specimens are performed monotonically, external load is applied until the collapse of the specimen is obtained.

Test on storey high panels with applied shotcrete is performed applying monotonic and/or cyclic loading.

Test velocity

Loading and unloading on the specimen should be in such a way as to avoid any dynamic effects. To this aim a velocity not higher than 2 mm/sec can be considered acceptable if the tests are conducted displacement controlled or not higher than $\frac{N_r}{500 \text{ sec}}$ N/sec if the tests are conducted force controlled.

Where

N_r N Estimated collapse load

Testing mode

Cyclic testing should be performed to identify the following response aspects:

- Elastic stiffness
- Transition between elastic and cracked phase (force and displacement)
- Transition between cracked and yielded phase (force and displacement)
- Collapse point (force and displacement)
- Maximum force resistant by the specimen
- Capacity of the specimen to sustain repeated cycles at the same displacement
- Unloading behaviour
- Dissipation capacity

To obtain the previous indications the cyclic tests are conducted as follow.

- 1 Estimation of key points in the expected response curve (phase transitions and collapse)
- 2 Identification of the intermediate (between 0 and collapse) target displacements to be used to apply the external cyclic action are:
 - a target 1 = transition elastic/cracked phase
 - b target 2 = intermediate between transition elastic/cracked phase and transition cracked/yielded phase
 - c target 3 = transition cracked/yielded phase

- d target 4 = between transition cracked/yielded phase and collapse (target 4 can be replicated increasing the displacement toward the collapse)
 - e target 5 = 10 %-20 % higher than collapse
- 3 each target displacements is the amplitude of the cycles applied to the specimen – cycles start from 0 displacement –, each cycles is be repeated 3 times
 - 4 the specimen collapse is attained once the force recorded during the cycle drop by more than 20 % of the maximum force displayed in the cycles

Plot vertical load vs vertical deflection curve.

- Initial stiffness of the panel with applied shotcrete

2.2.9 Resistance to corrosion

Corrosion protection is ensured by sufficient concrete cover and by the use of stainless steel according to EN 10088, see Clause 2.2.29.

Testing regarding corrosion is not required. The prescriptive specifications of EN 1992-1-1 and EN 206 regarding exposure classes and concrete cover shall apply.

2.2.10 Reaction to fire

The panels with applied shotcrete are tested, using the test method(s) relevant for the corresponding reaction to fire class, in order to be classified according to EN 13501 1.

The panels with applied shotcrete are comprised of concrete, steel wires, and thermal insulation material of expanded polystyrene, EPS.

Concrete is considered to satisfy the requirements for performance class A1 of the characteristic reaction to fire in accordance with the Commission Decision 96/603/EC, as amended, without the need for testing on the basis of it fulfilling the conditions set out in that Decision and its intended use being covered by that Decision.

Therefore the performance of concrete is A1.

Steel wire is considered to satisfy the requirements for performance class A1 of the characteristic reaction to fire in accordance with the Commission Decision 96/603/EC, as amended, without the need for testing on the basis of it fulfilling the conditions set out in that Decision and its intended use being covered by that Decision.

Therefore the performance of steel wire is A1.

Thermal insulation material of expanded polystyrene, EPS, is tested and classified according to Clause 2.2.37.

Alternatively to test and classify the panels with applied shotcrete for reaction to fire, the classification of the thermal insulation material is validated for the panels with applied shotcrete.

2.2.11 Resistance to fire

The part of the works or assembled system in which the panels is intended to be incorporated, installed or applied shall be tested, using the test method relevant for the corresponding fire resistance class, in order to be classified according to the appropriate part of EN 13501.

2.2.12 Vapour permeability

Design values of material characteristics can be taken from EN ISO 10456. Water vapour transmission characteristics can be determined, if deemed necessary, in accordance with EN 12086.

2.2.13 Airborne sound insulation

Testing as performed as described in EN ISO 140-3. The result are expressed as a single number rating in accordance with EN ISO 717-1.

2.2.14 Thermal resistance

Design values of material properties are taken from EN ISO 10456. For thermal conductivity of thermal insulation material of expanded polystyrene, EPS, see Clause 2.2.44

2.2.15 Thermal inertia

Regarding thermal inertia, the following information are given.

- Configuration, i.e. by indicating the consecutive layers with their dimensions
- Densities of materials
- Specific heat capacities of materials
- Thermal conductivities of materials

Design values of material properties are determined according to Clause 2.2.15.

2.2.16 Air tightness

Panels with applied shotcrete and finishes are in general considered as satisfactory impermeable to air without being tested.

If testing is deemed necessary, it is performed according to EN 12114.

Essential characteristics of the welded fabric

2.2.17 Mechanical characteristics

The welded fabric is tested according to EN ISO 15630-2 regarding

- yield strength
- tensile strength
- ratio tensile strength to yield strength
- elongation at maximum load

Mechanical characteristics of the welded fabric are evaluated in accordance with EN 10080. The lower limit of the statistical tolerance interval applies in regard to

- Yield strength and tensile strength with a 5 % fractile as characteristic value
- Ratio tensile strength to yield strength and elongation at maximum load with a 10 % fractile as characteristic value

2.2.18 Weld shear force

The welded fabric is tested according to EN ISO 15630-2 regarding weld shear force. Weld shear force of the welded fabric is evaluated in accordance with EN 10080.

2.2.19 Bending

The welded fabric is tested according to EN ISO 15630-2 regarding bending. Bending of the welded fabric is evaluated in accordance with EN 10080.

2.2.20 Dimensions

The welded fabric is tested according to EN ISO 15630-2 regarding

- Nominal diameters of longitudinal and transverse wire
- Dimensions of welded fabric.

Dimensions and tolerances of the welded fabric are evaluated in accordance with EN 10080.

2.2.21 Mass

The welded fabric is tested according to EN ISO 15630-1 regarding mass of longitudinal and transverse wire. Mass and tolerances of the welded fabric is evaluated in accordance with EN 10080.

2.2.22 Resistance to corrosion

Galvanised welded fabric is tested by diluting the zinc coating and determination of mass of zinc per area. Zinc coating expressed as mass of zinc by area is evaluated according to EN 10244-2.

2.2.23 Reaction to fire

Welded fabric of steel wires is considered to satisfy the requirements for performance class A1 of the characteristic reaction to fire in accordance with the Commission Decision 96/603/EC, as amended, without the need for testing on the basis of it fulfilling the conditions set out in that Decision and its intended use being covered by that Decision.

Therefore the performance of welded fabric is A1.

Essential characteristics of the connectors of stainless steel

2.2.24 Mechanical characteristics

The connector of stainless steel is tested according to EN ISO 6892-1 regarding

- Yield strength
- Tensile strength
- Elongation after fracture

Mechanical characteristics of the connectors of stainless steel is evaluated in accordance with EN 10088.

2.2.25 Weld shear force

The connector of stainless steel is tested according to EN ISO 15630-2 regarding weld shear force. Weld shear force of the connector of stainless steel is evaluated in accordance with EN 10080.

2.2.26 Dimensions

The diameter of the connector of stainless steel is tested according to EN 10218-2. Diameter and tolerances of the connector of stainless steel is evaluated in accordance with EN 10218-2.

2.2.27 Mass

Mass of the connector of stainless steel is determined with the nominal diameter and the density according to EN 10088.

2.2.28 Resistance to corrosion

Resistance to corrosion of the connector of stainless steel is determined according to material and its chemical composition as given in EN 10088 and EN 1993-1-4.

2.2.29 Reaction to fire

The connector of stainless steel wires is considered to satisfy the requirements for performance class A1 of the characteristic reaction to fire in accordance with the Commission Decision 96/603/EC, as amended, without the need for testing on the basis of it fulfilling the conditions set out in that Decision and its intended use being covered by that Decision.

Therefore the performance of connector of stainless steel wires is A1.

2.2.30 Thermal conductivity

Design value of thermal conductivity of the connector of stainless steel is taken from EN ISO 10456.

2.2.31 Specific heat capacity

Design value of specific heat capacity of the connector of stainless steel is taken from EN ISO 10456.

Essential characteristics of the thermal insulation material of expanded polystyrene, EPS

2.2.32 Dimensional stability

Dimensional stability under constant normal laboratory conditions and under specified temperature and humidity conditions is determined according to EN 13163.

2.2.33 Compressive creep

Compressive creep is determined according to EN 13163.

2.2.34 Compressive stress at 10 % deformation

Compressive stress at 10 % deformation is determined according to EN 13163.

2.2.35 Shear behaviour

Shear behaviour is works 2

2.2.36 Reaction to fire

The core of expanded polystyrene, EPS, shall be tested, using the test method(s) relevant for the corresponding reaction to fire class, in order to be classified according to EN 13501-1.

2.2.37 Water vapour transmission

Water vapour transmission is determined according to EN 13163.

2.2.38 Apparent density

Apparent density is determined according to EN 13163.

2.2.39 Bending strength

Bending strength is determined according to EN 13163.

2.2.40 Shape

The shape of the thermal insulation material is determined by visual inspection by reference to workshop drawings. The shape of the thermal insulation material is given in representations like outline drawings.

2.2.41 Dimensions

Dimensions is determined according to EN 13163.

2.2.42 Squareness

Squareness is determined according to EN 13163.

2.2.43 Thermal conductivity

The thermal conductivity of the thermal insulation material is determined according to EN 13163.

3 ASSESSMENT AND VERIFICATION OF CONSTANCY OF PERFORMANCE

3.1 System(s) of assessment and verification of constancy of performance to be applied

For the products covered by this EAD the applicable European legal act is: Decision 2003/728/EC

The system is: 1

3.2 Tasks of the manufacturer

The cornerstones of the actions to be undertaken by the manufacturer of the product in the procedure of assessment and verification of constancy of performance are laid down in Table 5 to Table 8.

Table 5 Control plan for the manufacturer – Panels – Cornerstones

No	Subject/type of control Product, raw/constituent material, component – indicating characteristic concerned	Test or control method	Criteria, if any	Minimum number of samples	Minimum frequency of control
Factory production control (FPC) including testing of samples taken at the factory in accordance with a prescribed test plan					
1	Visual inspection of panels	1)	1)	—	100 %
2	Dimensions, squareness of panels	2)	2)	2	Per shift ³⁾
¹⁾ Visual inspections means completeness of configuration, damage, open welds, corrosion, main dimensions, flatness, correct marking or labelling, appropriate performance declaration, surface, according to the panel's specification ²⁾ Determination of detailed dimensions including component's dimensions according to the panel's specification ³⁾ Per shift and per produced panel configuration					

Table 6 Control plan for the manufacturer – Welded fabric – Cornerstones

No	Subject/type of control Product, raw/constituent material, component – indicating characteristic concerned	Test or control method	Criteria, if any	Minimum number of samples	Minimum frequency of control
Factory production control (FPC)					
1	Material	"3.1" ¹⁾	2)	—	100 %
2	Dimensions, mass, and tolerances	2.2.21, 2.2.22	2)	3)	3)
3	Mechanical properties	2.2.18	2)	3)	3)
4	Weld shear force	2.2.19	2)	3)	3)
5	Bending	2.2.20	2)	3)	3)
6	Visual inspection	4)	3)	—	100 %

No	Subject/type of control Product, raw/constituent material, component – indicating characteristic concerned	Test or control method	Criteria, if any	Minimum number of samples	Minimum frequency of control
1)	Inspection certificate “3.1” according to EN 10204				
2)	As defined by the component’s specification				
3)	Per diameter and rolling bath, at least however, as specified in EN 10080, clause 8.1				
4)	Visual inspections means e.g. main dimensions, appropriate declared performance, surface, fins, kinks, smoothness, corrosion, open welds, according to the component’s specification.				

Table 7 Control plan for the manufacturer – Connectors of stainless steel – Cornerstones

No	Subject/type of control Product, raw/constituent material, component – indicating characteristic concerned	Test or control method	Criteria, if any	Minimum number of samples	Minimum frequency of control
Factory production control (FPC)					
1	Material	“3.1” ¹⁾	2)	—	100 %
2	Dimensions, mass, and tolerances	2.2.27, 2.2.28	2)	3)	3)
3	Mechanical properties	2.2.25	2)	3)	3)
4	Weld shear force	2.2.26	2)	3)	3)
5	Visual inspection	4)	3)	—	100 %
1)	Inspection certificate “3.1” according to EN 10204				
2)	As defined by the component’s specification				
3)	Per diameter and rolling bath, at least however, as specified in EN 10080, clause 8.1				
4)	Visual inspections means e.g. main dimensions, appropriate declared performance, surface, fins, kinks, smoothness, corrosion, open welds, according to the component’s specification.				

Table 8 Control plan for the manufacturer – Core of expanded polystyrene, EPS – Cornerstones

No	Subject/type of control Product, raw/constituent material, component – indicating characteristic concerned	Test or control method	Criteria, if any	Minimum number of samples	Minimum frequency of control
Factory production control (FPC)					
1	Reaction to fire	2.2.37	1)	2)	2)
2	Apparent density	2.2.39	1)	2)	2)
3	Bending strength	2.2.40	1)	2)	2)

No	Subject/type of control Product, raw/constituent material, component – indicating characteristic concerned	Test or control method	Criteria, if any	Minimum number of samples	Minimum frequency of control
4	Dimensions and squareness	2.2.33, 2.2.41, 2.2.42, 2.2.43	1)	2)	2)
5	Thermal conductivity	2.2.44	1)	2)	2)
6	Compressive stress at 10 % deformation	2.2.35	1)	2)	2)
7	Shear behaviour	2.2.36	1)	2)	2)
8	Visual inspection	3)	3)	—	100 %
<p>1) As defined by the component's specification</p> <p>2) As specified in EN 13163</p> <p>3) Visual inspections means e.g. main dimensions, appropriate declared performance, surface, according to the component's specification.</p>					

3.3 Tasks of the notified body

The cornerstones of the actions to be undertaken by the notified body in the procedure of assessment and verification of constancy of performance for “Panels of steel wires with incorporated thermal insulation for a whole structure” are laid down in Table 9 to Table 12.

Table 9 Control plan for the notified body – Panels – Cornerstones

No	Subject/type of control Product, raw/constituent material, component – indicating characteristic concerned	Test or control method	Criteria, if any	Minimum number of samples	Minimum frequency of control
Initial inspection of the manufacturing plant and of factory production control					
1	The notified product certification body shall verify the ability of the manufacturer for a continuous and orderly manufacturing of the product according to the European Technical Assessment. In particular the following items shall be appropriately considered <ul style="list-style-type: none"> – personnel and equipment – the suitability of the factory production control established by the manufacturer – full implementation of the prescribed test plan 				—
Continuous surveillance, assessment and evaluation of factory production control					
2	The notified product certification body shall verify <ul style="list-style-type: none"> – the manufacturing process – the system of factory production control – the implementation of the prescribed test plan are maintained.				1 per year

Table 10 Control plan for the notified body – Welded fabric – Cornerstones

No	Subject/type of control Product, raw/constituent material, component – indicating characteristic concerned	Test or control method	Criteria, if any	Minimum number of samples	Minimum frequency of control
Initial inspection of the manufacturing plant and of factory production control					
1	The notified product certification body shall verify the ability of the manufacturer for a continuous and orderly manufacturing of the product according to the European Technical Assessment. In particular the following items shall be appropriately considered <ul style="list-style-type: none"> – personnel and equipment – the suitability of the factory production control established by the manufacturer – full implementation of the prescribed test plan 				—
Continuous surveillance, assessment and evaluation of factory production control					
2	The notified product certification body shall verify <ul style="list-style-type: none"> – the manufacturing process – the system of factory production control – the implementation of the prescribed test plan are maintained.				1 per year

Table 11 Control plan for the notified body – Connector of stainless steel – Cornerstones

No	Subject/type of control Product, raw/constituent material, component – indicating characteristic concerned	Test or control method	Criteria, if any	Minimum number of samples	Minimum frequency of control
Initial inspection of the manufacturing plant and of factory production control					
1	The notified product certification body shall verify the ability of the manufacturer for a continuous and orderly manufacturing of the product according to the European Technical Assessment. In particular the following items shall be appropriately considered <ul style="list-style-type: none"> – personnel and equipment – the suitability of the factory production control established by the manufacturer – full implementation of the prescribed test plan 				—

No	Subject/type of control Product, raw/constituent material, component – indicating characteristic concerned	Test or control method	Criteria, if any	Minimum number of samples	Minimum frequency of control
Continuous surveillance, assessment and evaluation of factory production control					
2	The notified product certification body shall verify <ul style="list-style-type: none"> – the manufacturing process – the system of factory production control – the implementation of the prescribed test plan are maintained.				1 per year

Table 12 Control plan for the notified body – Core of expanded polystyrene, EPS – Cornerstones

No	Subject/type of control Product, raw/constituent material, component – indicating characteristic concerned	Test or control method	Criteria, if any	Minimum number of samples	Minimum frequency of control
Initial inspection of the manufacturing plant and of factory production control					
1	The notified product certification body shall verify the ability of the manufacturer for a continuous and orderly manufacturing of the product according to the European Technical Assessment. In particular the following items shall be appropriately considered <ul style="list-style-type: none"> – personnel and equipment – the suitability of the factory production control established by the manufacturer – full implementation of the prescribed test plan 				—
Continuous surveillance, assessment and evaluation of factory production control					
2	The notified product certification body shall verify <ul style="list-style-type: none"> – the manufacturing process – the system of factory production control – the implementation of the prescribed test plan are maintained.				1 per year

4 REFERENCE DOCUMENTS

As far as no edition date is given in the list of standards thereafter, the standard in its current version at the time of issuing the European Technical Assessment, is of relevance.

EN 206-1, 12.2000 EN 206-1/A1, 07.2004 EN 206-1/A2, 06.2005	Concrete – Part 1: Specification, performance, production and conformity
EN 1992-1-1, 12.2004 EN 1992-1-1/AC, 11.2010	Eurocode 2: Design of concrete structures – Part 1-1: General rules and rules for buildings
EN 10080, 05.2005	Steel for the reinforcement of concrete – Weldable reinforcing steel – General
EN 10088-1, 06.2005	Stainless steels – Part 1: List of stainless steels
EN 10204, 10.2004	Metallic products – Types of inspection documents
EN 10218-2	Steel wire and wire products – General – Part 2: Wire dimensions and tolerances
EN 10244-2	Steel wire and wire products – Non-ferrous metallic coatings on steel wire – Part 2: Zinc or zinc alloy coatings
EN 12086, 06.1997	Thermal insulating products for building applications – Determination of water vapour transmission properties
EN 12114, 03.2000	Thermal performances of buildings – Air permeability of building components and building elements – Laboratory test method
EN 12664, 01.2001	Thermal performance of building materials and products – Determination of thermal resistance by means of guarded hot plate and heat flow meter methods – Dry and moist products of medium and low thermal resistance
EN 13163, 11.2008	Thermal insulation products for buildings – Factory made products of expanded polystyrene (EPS) – Specification
EN 13501-1+A1, 09.2009	Fire classification of construction products and building elements – Part 1: Classification using data from reaction to fire tests
EN 13501-2+A1, 09.2009	Fire classification of construction products and building elements – Part 2: Classification using data from fire resistance tests, excluding ventilation services
EN 14487-1, 11.2005	Sprayed concrete – Part 1: Definitions, specifications and conformity
EN 14487-2, 10.2006	Sprayed concrete – Part 2: Execution
EN ISO 140-1, 05.1995	Acoustics – Measurement of sound insulation in buildings and of building elements – Part 3: Laboratory measurements of airborne sound insulation of building elements
EN ISO 717-1, 12.1996	Acoustics – Rating of sound insulation in buildings and of building elements – Part 1: Airborne sound insulation

EN ISO 6892-1	Metallic materials – Tensile testing – Part 1: Method of test at room temperature
EN ISO 6946, 12.2007	Building components and building elements – Thermal resistance and thermal transmittance – Calculation method
EN ISO 10140-2, 09.2010	Acoustics – Laboratory measurement of sound insulation of building elements – Part 2: Measurement of airborne sound insulation
EN ISO 10456, 12.2007 EN ISO 10456/AC, 12.2009	Building materials and products – Hygrothermal properties – Tabulated design values and procedures for determining declared and design thermal values
EN ISO 15630-1	Steel for the reinforcement and prestressing of concrete – Test methods – Part 1: Reinforcing bars, wire rod and wire
EN ISO 15630-2	Steel for the reinforcement and prestressing of concrete – Test methods – Part 2: Welded fabric

ANNEX 1 - DETAILS FOR CHARACTERISATION

The product that is the subject of the European Technical Assessment is characterised by:

- Diameter of steel wires of
 - welded fabric and
 - connectors of stainless steel
- Dimensions of welded fabric
- Number of connectors of stainless steel per square metre
- Mechanical characteristics of
 - welded fabric and
 - connectors of stainless steel
- Shape and dimensions of polystyrene panels
- Characteristics of polystyrene panels

ANNEX 2 - COMPONENTS OF THE KIT

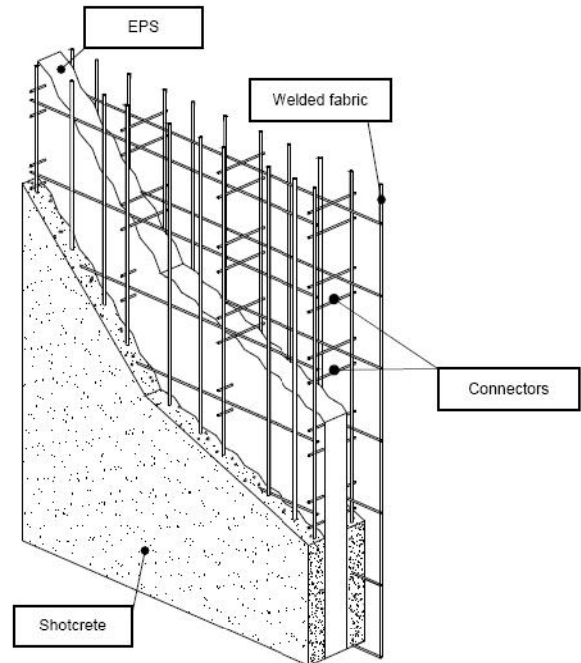
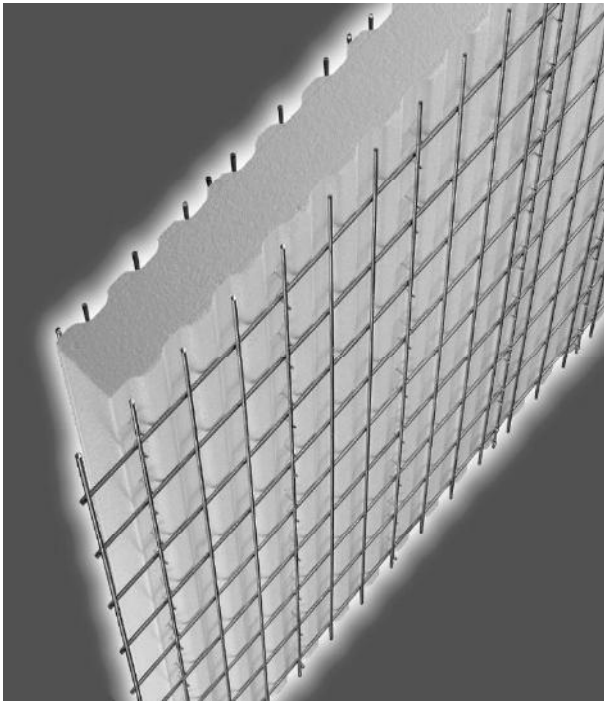

Figure 11 Components of the kit

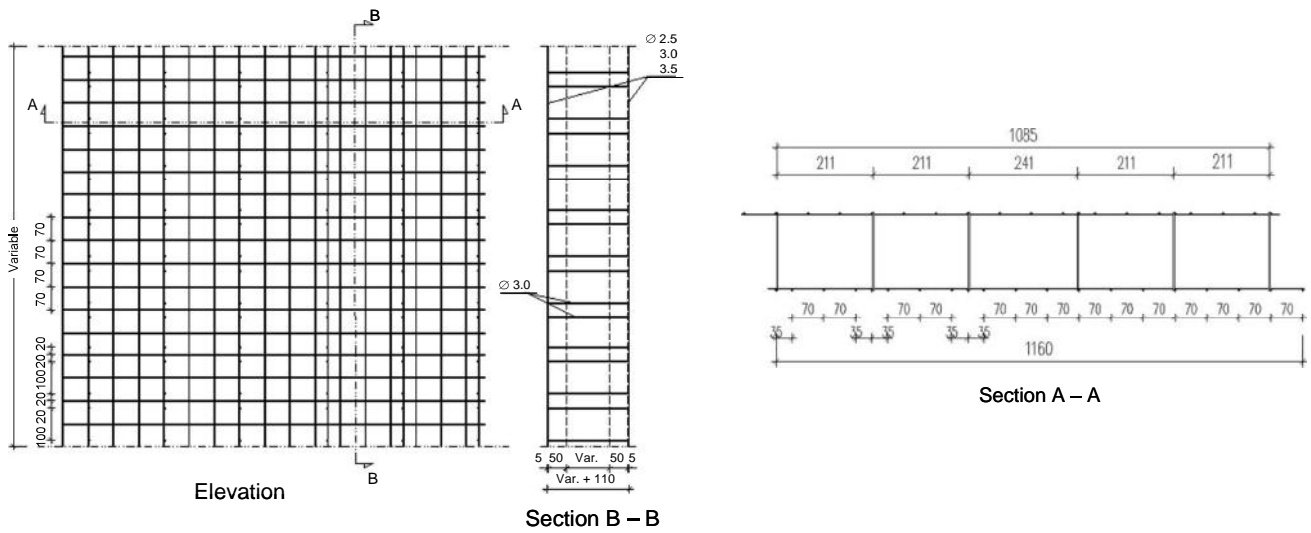

Figure 12 Typical geometry of welded fabric – Example

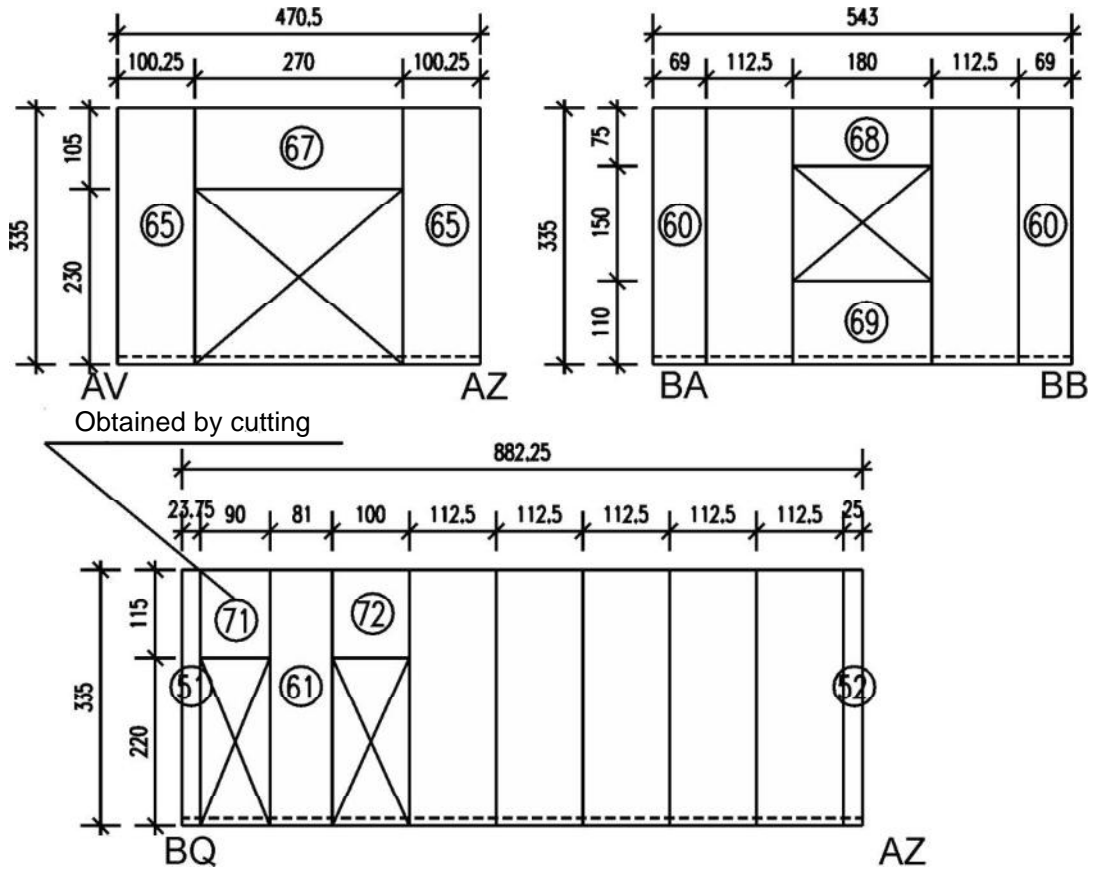

Figure 13 Example of panel installation

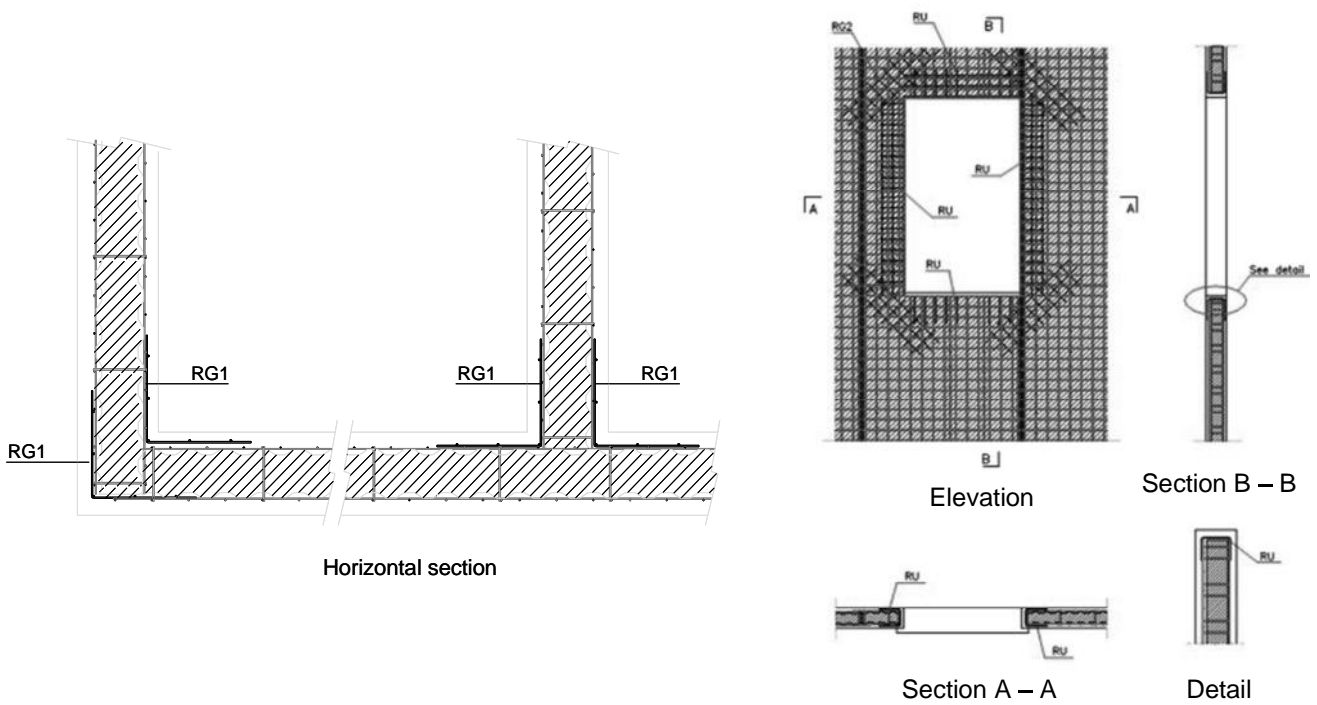

Figure 14 Strips and sheets of welded fabric – Example

ANNEX 3 - NUMBER OF SPECIMENS

№	Description of the specimen	Purpose of test	I-loading	Testing protocol	Number of specimens	Measurements and observations	
1	Small-size panels approximately 1.0 m × 1.0 m	Resistance to compression and traction, stiffness, equivalent resisting area, see Figure 16	Compression centred	Pseudo static monotonic loading	2	In-plane deformations, axial force	
2			Compression asymmetric		2	In-plane deformations, axial force	
3			Compression diagonal		2	In-plane deformations, diagonal force	
4			In-plane shear delamination		2	In-plane deformation, shear force	
5	Panels without opening h = storey height, b > 1.0 m	Relation between resistance and buckling, see Figure 17	Compression centred	Pseudo static monotonic loading	2	In-plane deformations, axial force	
6	Full scale panels h = storey height, aspect ratio b : h = 1 : 1 and b : h = 4 : 3	Ultimate load, stiffness, displacement capacity, dissipation, stability of cycles, collapse mode, see Figure 18	Combined axial load and in-plane shear Two axial load levels are adopted	Pseudo static cyclic loading	2 per aspect ratio, 1 per each axial load	In-plane deformations, axial force and horizontal force	
7					without opening		2 per aspect ratio, 1 per each axial load
8					with door		2 per aspect ratio, 1 per each axial load
9	Joint	Identification of connection strength between elements, see Figure 19	Axial load and transversal shear	Pseudo static cyclic loading	2	Deformations and forces	
10					with window		2
11	Slab	Stiffness, see Figure 20	Transversal shear, flexural moment	Pseudo static monotonic loading	8	Out-of-plane deformations, force failure modes	

ANNEX 4 - SPECIMENS

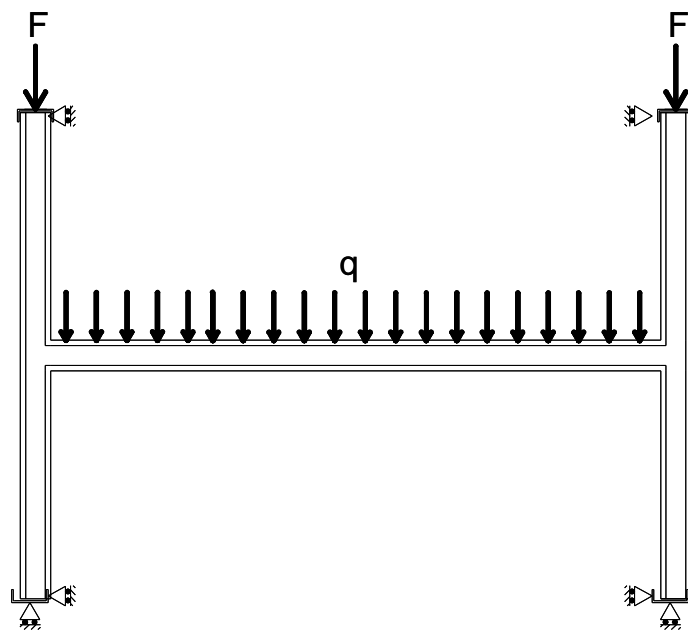

Figure 15 Wall and floor specimen – testing long-term performance

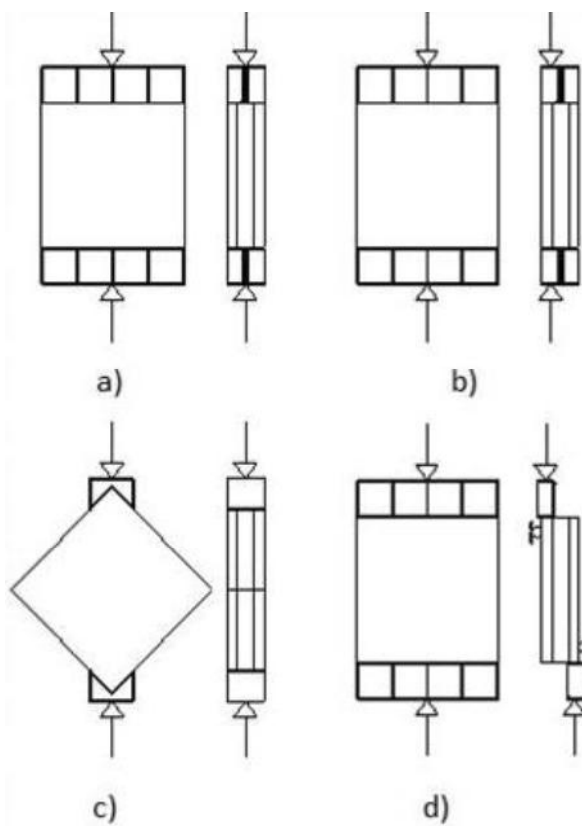

Figure 16 Small specimens
 a) centric compression
 b) eccentric compression
 c) diagonal compression
 d) in-plane shear, delamination

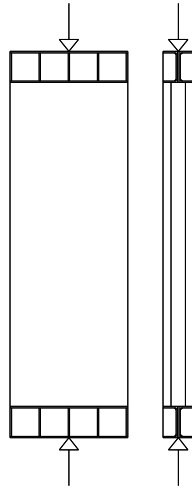

Figure 17 Storey high specimen – testing stability

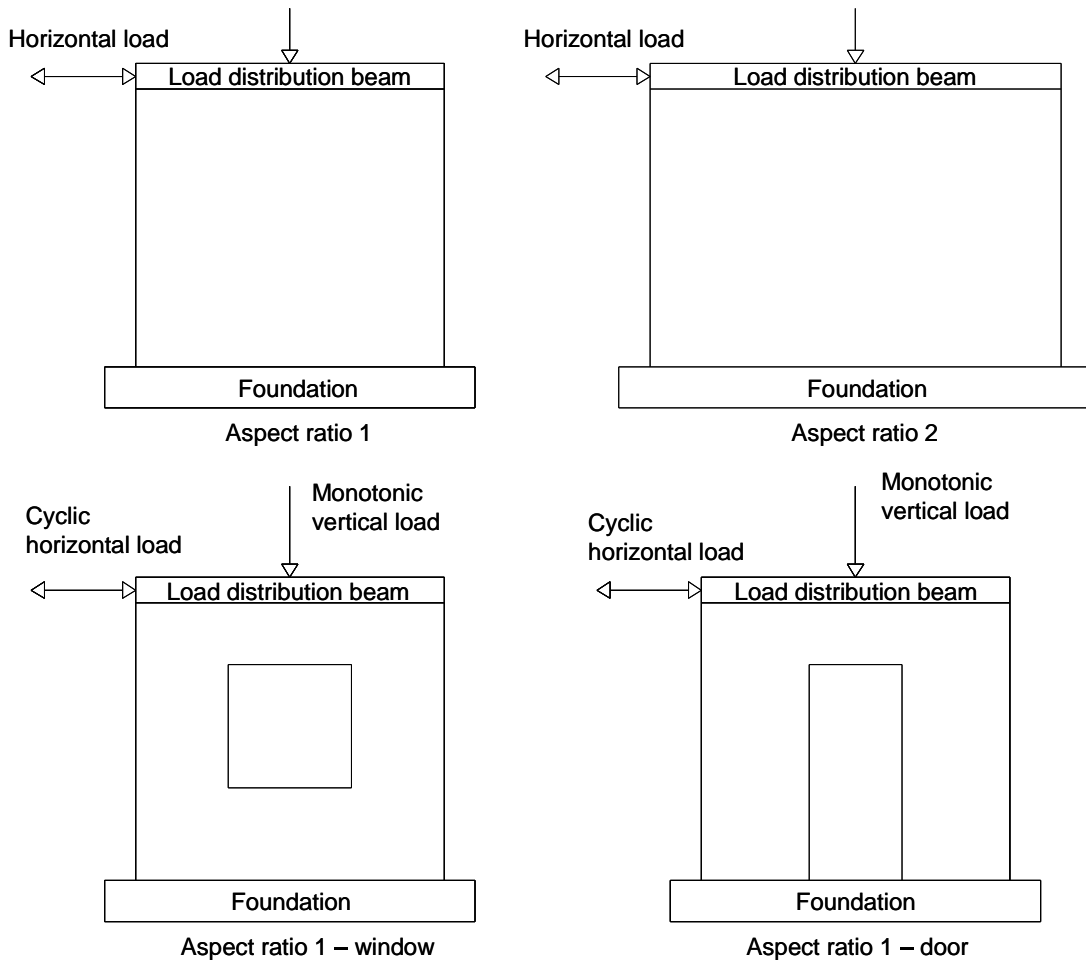

Figure 18 Specimens for cyclic testing

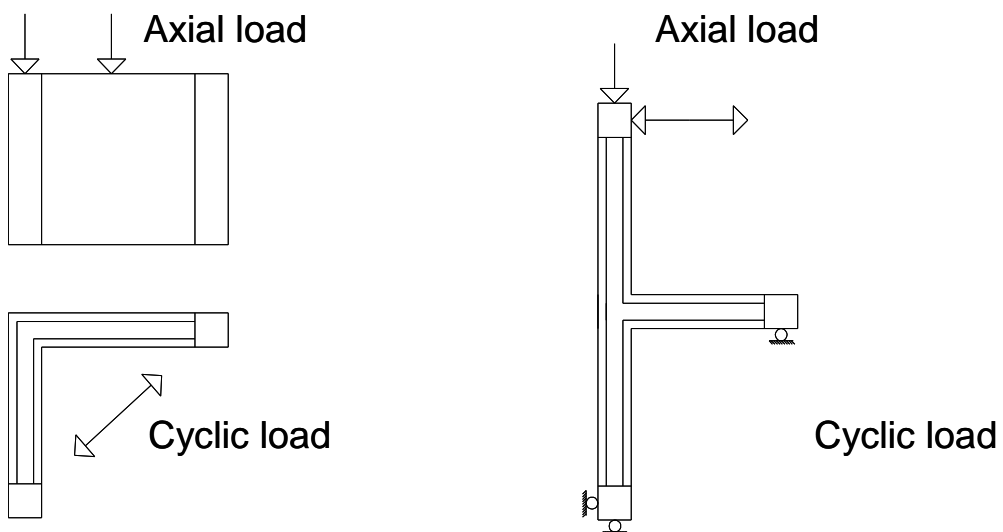

Figure 19 Cyclic testing of joints

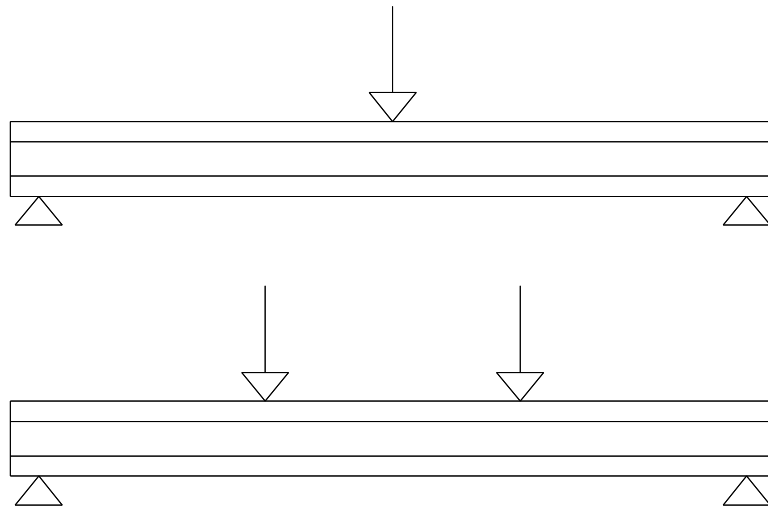

Figure 20 Testing of slabs